

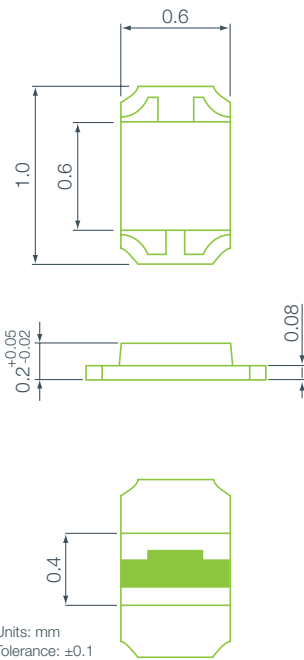

Ultra-compact PicoLED™-eco

ROHM has developed the PicoLED™-eco (SML-P11) series of ultra-compact LEDs. Patented technology results in twice the brightness as conventional products in the low current region of 1mA - all from one of the industry's smallest, thinnest packages that are 53% and 74% smaller in area and volume, respectively, than the conventional 1608 (0603) size. Energy consumption is approximately 50% less at the same brightness, and the high reliability four-element structure (AlGaInP) prevents brightness degradation - even after long term, continuous use. These LEDs are available in red, orange, yellow, and green, and their low power consumption makes them ideal for compact portable, battery driven devices.



Key Features

- Smallest, thinnest LEDs on the market (1.0mm x 0.6mm, t=0.2mm), 53% less area and 74% smaller volume than conventional 1608 size products
- Twice the brightness as conventional products in the low current range (1mA) reduces power consumption by 50%
- High reliability AlGaInP construction prevents brightness degradation - even after long-term, continuous use

Applications

- Mobile phones
- Dot matrices
- 7-segment light sources

Pricing

Quantity per reel: 3,000 pieces

Price: \$0.10

Samples: Available now

Part No.	LED chip	Emitting color	Absolute maximum ratings (Ta=25°C)						Electrical and optical characteristics (Ta=25°C)										RoHS		
			Power dissipation Pc (mW)	Forward current If (mA)	Peak forward current Ifp (mA)	Reverse voltage Vr (V)	Operating temperature Topr (°C)	Storage temperature Tstg (°C)	Forward voltage Vf		Reverse current Ir		Light wave length			Brightness Iv					
									Typ. (V)	If (mA)	Max. (µA)	Vr (V)	Min. (nm)	λD Typ. (nm)	Max. (nm)	Min. (mcd)	Typ. (mcd)	If (mA)			
SML-P11VT	AlGaInP on GaAs	Red	50	20	100	5	-40 to +85	-40 to +100	1.8	1	100	4	621	626	631	1	3.6	1	Yes		
SML-P11UT		Orange	616										621	626	1.6	5.5	Yes				
SML-P11DT			Yellow										602	605	608	2.5				7.3	Yes
SML-P11YT													583	586	589	0.63				2.1	
SML-P11MT			Yellow-Green										54	566	569	572				0.63	2.1

More info

http://www.rohm.com/products/opto_device/led/picoled/

http://www.rohm.com/products/ecodevices/category/opto_device.html