

## LED Drivers for LCD Backlights

# White Backlight LED Driver for Medium to Large LCD Panels (Switching Regulator Type)



BD8119FM-M

No.10040EAT17

## ●Description

BD8119FM-M is a white LED driver with the capability of withstanding high input voltage (36V MAX).

This driver has 4ch constant-current drivers integrated in 1-chip, which each channel can draw up to 150mA max, so that high brightness LED driving can be realized.

Furthermore, a current-mode buck-boost DC/DC controller is also integrated to achieve stable operation against unstable car-battery voltage input and also to remove the constraint of the number of LEDs in series connection.

The brightness can be controlled by either PWM or VDAC techniques.

## ●Features

- 1) Input voltage range is 5.0 to 30 V
- 2) Integrated buck-boost current-mode DC/DC controller
- 3) Four integrated LED current driver channels (150mA max. each channel)
- 4) PWM Light Modulation (Minimum Pulse Width 25 $\mu$ s)
- 5) Built-in protection functions (UVLO, OVP, TSD, OCP, SCP)
- 6) Abnormal status detection function (OPEN/ SHORT)
- 7) HSOP-M28 package

## ●Applications

Backlight for car navigation, dashboard panels, etc.

(※ Recommended Component of Toshiba Matsushita Display Technology Co.,Ltd. )

## ●Absolute maximum ratings (Ta=25°C)

Parameter	Symbol	Ratings	Unit
Power supply voltage	V <sub>CC</sub>	36	V
BOOT Voltage	V <sub>BOOT</sub>	41	V
SW,CS,OUTH Voltage	V <sub>SW</sub> , V <sub>CS</sub> , V <sub>OUTH</sub>	36	V
BOOT-SW Voltage	V <sub>BOOT-SW</sub>	7	V
LED output voltage	V <sub>LED1~4</sub>	36	V
VREG, OVP, OUTL, FAIL1, FAIL2, LEDEN1, LEDEN2, ISET, VDAC, PWM, SS, COMP, RT, SYNC, EN Voltage	V <sub>VREG</sub> , V <sub>OVP</sub> , V <sub>OUTL</sub> , V <sub>FAIL1</sub> , V <sub>FAIL2</sub> , V <sub>LEDEN1</sub> , V <sub>LEDEN2</sub> , V <sub>ISET</sub> , V <sub>VDAC</sub> , V <sub>PWM</sub> , V <sub>SS</sub> , V <sub>COMP</sub> , V <sub>RT</sub> , V <sub>SYNC</sub> , V <sub>EN</sub>	-0.3~7 < V <sub>CC</sub>	V
Power Consumption	P <sub>d</sub>	2.20 ※ <sup>1</sup>	W
Operating temperature range	T <sub>opr</sub>	-40~+95	°C
Storage temperature range	T <sub>stg</sub>	-55~+150	°C
LED maximum output current	I <sub>LED</sub>	150 ※ <sup>2</sup> ※ <sup>3</sup>	mA

※<sup>1</sup> IC mounted on glass epoxy board measuring 70mm×70mm×1.6mm, power dissipated at a rate of 17.6mW/°C at temperatures above 25°C.

※<sup>2</sup> Dispersion figures for LED maximum output current and V<sub>F</sub> are correlated. Please refer to data on separate sheet.

※<sup>3</sup> Amount of current per channel.

## ●Operating conditions (Ta=25°C)

Parameter	Symbol	Ratings	Unit
Power supply voltage	V <sub>CC</sub>	5.0~30	V
Oscillating frequency range	F <sub>OSC</sub>	250~550	kHz
External synchronization frequency range ※ <sup>4</sup> ※ <sup>5</sup>	F <sub>SYNC</sub>	fosc~550	kHz
External synchronization pulse duty range	F <sub>SDUTY</sub>	40~60	%

※<sup>4</sup> Connect SYNC to GND or OPEN when not using external frequency synchronization.

※<sup>5</sup> Do not switch between internal and external synchronization when an external synchronization signal is input to the device.

● **Electrical Characteristics** (unless otherwise specified,  $V_{CC}=12V$   $T_a=25^{\circ}C$ )

Parameter	Symbol	Limits			Unit	Conditions
		Min	Typ	Max.		
Circuit current	$I_{CC}$	-	7	14	mA	EN=Hi, SYNC=Hi, RT=OPEN PWM=Low, ISET=OPEN, $C_{IN}=10\mu F$
Standby current	$I_{ST}$	-	4	8	$\mu A$	EN=Low
<b>[VREG Block (VREG)]</b>						
Reference voltage	$V_{REG}$	4.5	5	5.5	V	$I_{REG}=-5mA$ , $C_{REG}=2.2\mu F$
<b>[OUTH Block]</b>						
OUTH high-side ON resistance	$R_{ONHH}$	1.0	3	4.5	$\Omega$	$I_{ON}=-10mA$
OUTH low-side ON resistance	$R_{ONHL}$	0.5	2	3.0	$\Omega$	$I_{ON}=10mA$
Over-current protection operating voltage	$V_{OLIMIT}$	$V_{CC}-0.66$	$V_{CC}-0.6$	$V_{CC}-0.54$	V	
<b>[OUTL Block]</b>						
OUTH high-side ON resistance	$R_{ONLH}$	1.0	3	4.5	$\Omega$	$I_{ON}=-10mA$
OUTH low -side ON resistance	$R_{ONLL}$	0.5	2	3.0	$\Omega$	$I_{ON}=10mA$
<b>[SW Block]</b>						
SW low -side ON resistance	$R_{ON\_SW}$	1.0	2.0	4.0	$\Omega$	$I_{ON\_SW}=10mA$
<b>[Error Amplifie Block]</b>						
LED voltage	$V_{LED}$	0.9	1.0	1.1	V	
COMP sink current	$I_{COMPSINK}$	15	25	35	$\mu A$	$V_{LED}=2V$ , $V_{comp}=1V$
COMP source current	$I_{COMPSOURCE}$	-35	-25	-15	$\mu A$	$V_{LED}=0V$ , $V_{comp}=1V$
<b>[Oscillator Block]</b>						
Oscillating frequency	$f_{OSC}$	250	300	350	KHz	$R_T=100k\Omega$
<b>[OVP Block]</b>						
Over-voltage detection reference voltage	$V_{OVP}$	1.9	2.0	2.1	V	$V_{OVP}$ =Sweep up
OVP hysteresis width	$V_{OHYS}$	0.45	0.55	0.65	V	$V_{OVP}$ =Sweep down
SCP Latch OFF Delay Time	$T_{SCP}$	70	100	130	ms	$R_T=100k\Omega$
<b>[UVLO Block ]</b>						
UVLO voltage	$V_{UVLO}$	4.0	4.3	4.6	V	$V_{CC}$ : Sweep down
UVLO hysteresis width	$V_{UHYS}$	50	150	150	mV	$V_{CC}$ : Sweep up

© This product is not designed for use in radioactive environments.

●Electrical Characteristics – Continued (unless otherwise specified, VCC=12V Ta=25°C)

Parameter	Symbol	Limits			Unit	Conditions
		Min	Typ	Max.		
<b>[LED Output Block]</b>						
LED current relative dispersion width	$\Delta I_{LED1}$	-3	-	+3	%	$I_{LED}=50mA$ , $\Delta I_{LED1}=(I_{LED}I_{LED\_AVG}-1) \times 100$
LED current absolute dispersion width	$\Delta I_{LED2}$	-5	-	+5	%	$I_{LED}=50mA$ , $\Delta I_{LED2}=(I_{LED}50mA-1) \times 100$
ISET voltage	$V_{ISET}$	1.96	2.0	2.04	V	$R_{ISET} 1=120k\Omega$
PWM minimum pulse width	$T_{min}$	25	-	-	$\mu s$	$F_{PWM}=150Hz$ , $I_{LED}=50mA$
PWM maximum duty	$D_{max}$	-	-	100	%	$F_{PWM}=150Hz$ , $I_{LED}=50mA$
PWM frequency	$f_{PWM}$	-	-	20	KHz	Duty=50%, $I_{LED}=50mA$
VDAC gain	$G_{VDAC}$	-	25	-	mA/V	$V_{DAC}=0\sim 2V$ , $R_{ISET}=120k\Omega$ $I_{LED}=VDAC \div R_{ISET} \times Gain$
Open detection voltage	$V_{OPEN}$	0.2	0.3	0.4	V	$V_{LED}$ = Sweep down
LED Short detection Voltage	$V_{SHORT}$	4.4	4.7	5.0	V	$V_{OVP}$ = Sweep up
LED Short Latch OFF Delay Time	$T_{SHORT}$	70	100	130	ms	$RT=100k\Omega$
PWM Latch OFF Delay Time	$T_{PWM}$	70	100	130	ms	$RT=100k\Omega$
<b>[Logic Inputs (EN, SYNC, PWM, LEDEN1, LEDEN2)]</b>						
Input HIGH voltage	$V_{INH}$	2.1	-	5.5	V	
Input LOW voltage	$V_{INL}$	GND	-	0.8	V	
Input current 1	$I_{IN}$	20	35	50	$\mu A$	$V_{IN}=5V$ (SYNC, PWM, LEDEN1, LEDEN2)
Input current 2	$I_{EN}$	15	25	35	$\mu A$	$V_{EN}=5V$ (EN)
<b>[FAIL Output (open drain) ]</b>						
FAIL LOW voltage	$V_{OL}$	-	0.1	0.2	V	$I_{OL}=0.1mA$

© This product is not designed for use in radioactive environments.

●Reference data (unless otherwise specified, Ta=25°C)

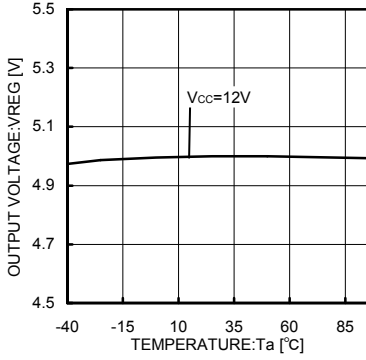

Fig.1 VREG temperature characteristic

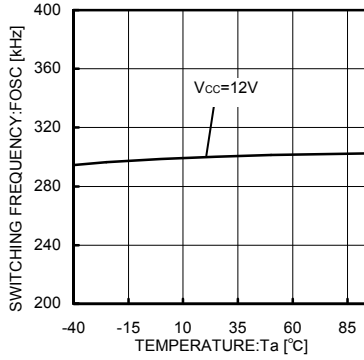

Fig.2 OSC temperature characteristic

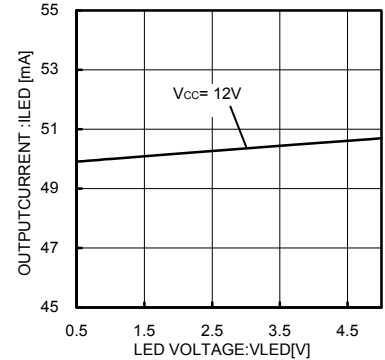

Fig.3 ILED depend on VLED

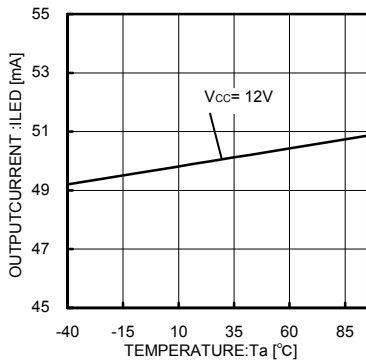

Fig.4 ILED temperature characteristic

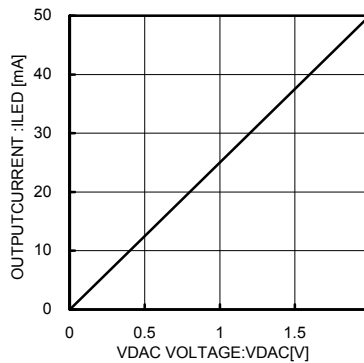

Fig.5 VDAC Gain①

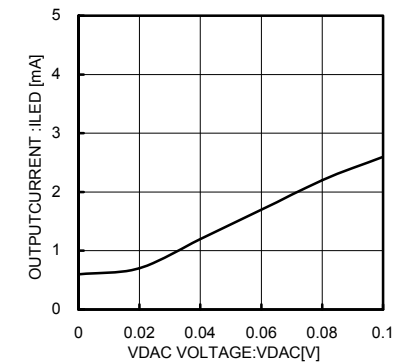

Fig.6 VDAC Gain②

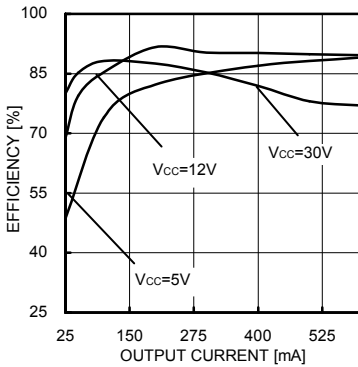

Fig.7 Efficiency (Depend on input voltage)

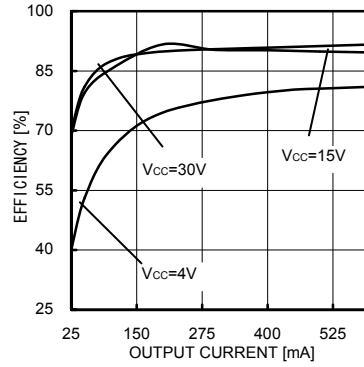

Fig.8 Efficiency (Depend on output voltage)

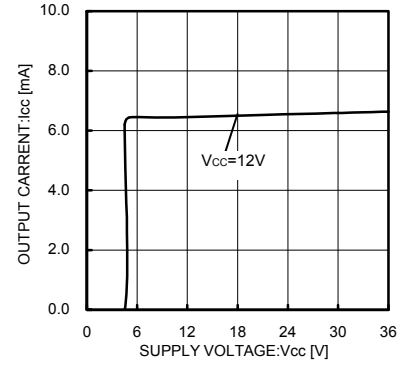

Fig.9 Circuit Current (Switching OFF)

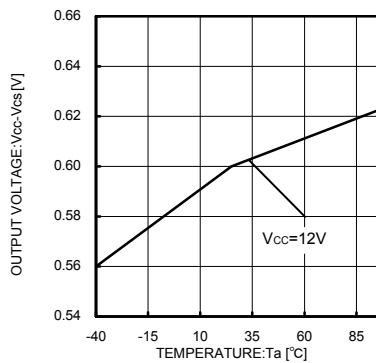

Fig.10 Overcurrent detecting voltage temperature characteristic

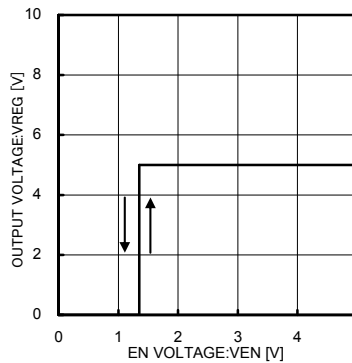

Fig.11 EN threshold voltage

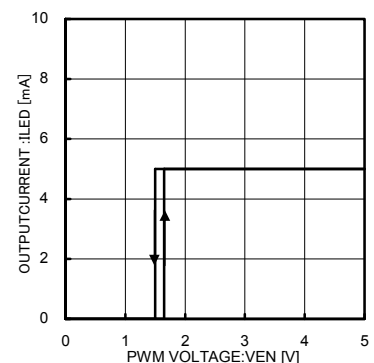

Fig.12 PWM threshold voltage

●Block diagram

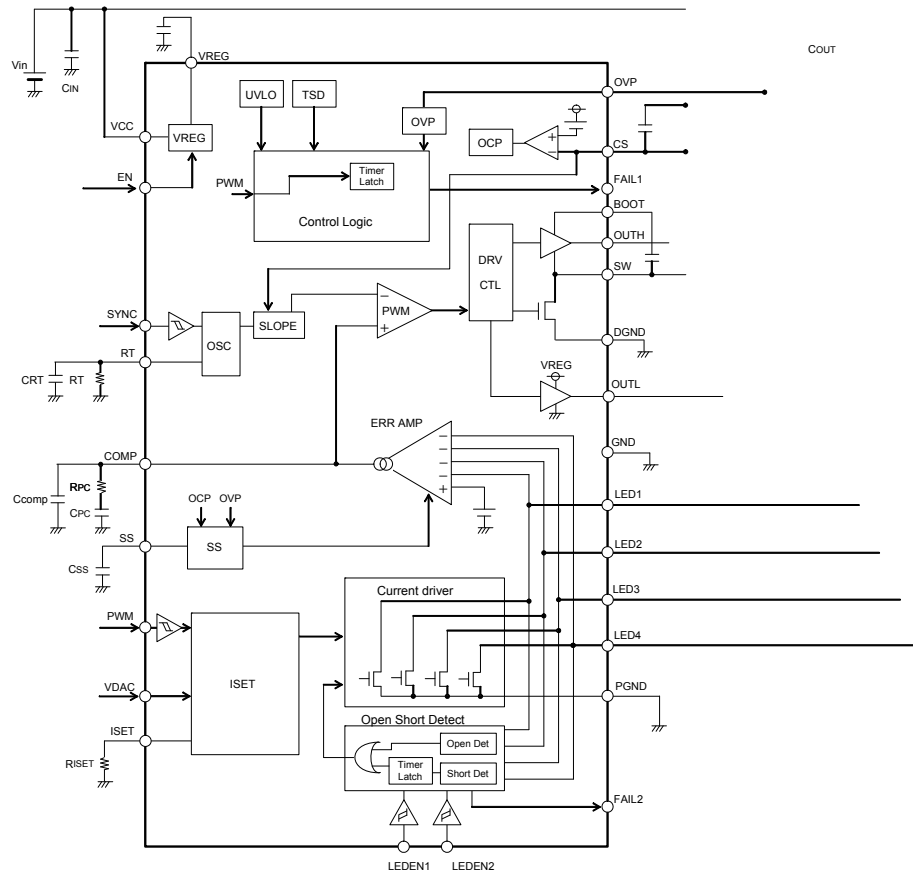

Fig.13

●Pin layout

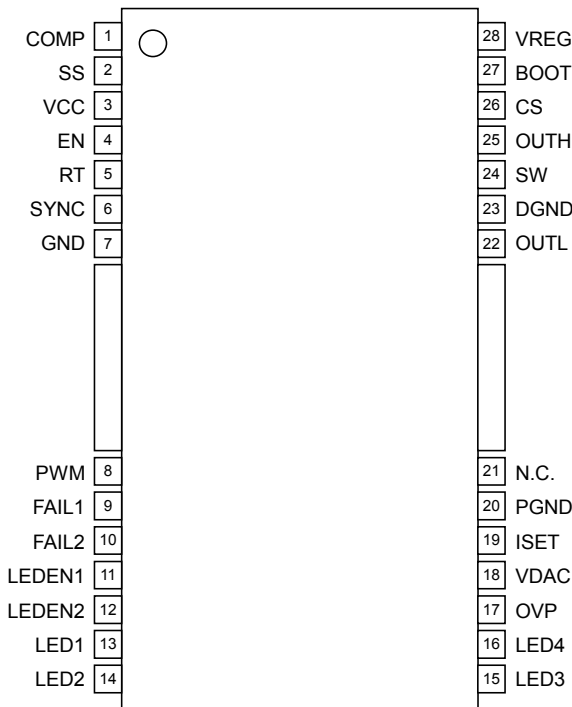

Fig.14

●Pin function table

Pin	Symbol	Function
1	COMP	Error amplifier output
2	SS	Soft start time-setting capacitance input
3	VCC	Input power supply
4	EN	Enable input
5	RT	Oscillation frequency-setting resistance input
6	SYNC	External synchronization signal input
7	GND	Small-signal GND
8	PWM	PWM light modulation input
9	FAIL1	Failure signal output
10	FAIL2	LED open/short detection signal output
11	LEDEN1	LED output enable pin 1
12	LEDEN2	LED output enable pin 2
13	LED1	LED output 1
14	LED2	LED output 2
15	LED3	LED output 3
16	LED4	LED output 4
17	OVP	Over-voltage detection input
18	VDAC	DC variable light modulation input
19	ISET	LED output current-setting resistance input
20	PGND	LED output GND
21	-	N.C.
22	OUTL	Low-side external MOSFET Gate Drive out put
23	DGND	Low-side internal MOSFET Source out put
24	SW	High-side external MOSFET Source pin
25	OUTH	High-side external MOSFET Gate Drive out pin
26	CS	DC/DC Current Sense Pin
27	BOOT	High-side MOSFET Power Supply pin
28	VREG	Internal reference voltage output

●5V voltage reference (VREG)

5V (Typ.) is generated from the V<sub>CC</sub> input voltage when the enable pin is set high. This voltage is used to power internal circuitry, as well as the voltage source for device pins that need to be fixed to a logical HIGH. UVLO protection is integrated into the VREG pin. The voltage regulation circuitry operates uninterrupted for output voltages higher than 4.5 V (Typ.), but if output voltage drops to 4.3 V (Typ.) or lower, UVLO engages and turns the IC off. Connect a capacitor (C<sub>reg</sub> = 2.2μF Typ.) to the VREG terminal for phase compensation. Operation may become unstable if C<sub>reg</sub> is not connected.

●Constant-current LED drivers

If less than four constant-current drivers are used, unused channels should be switched off via the LEDEN pin configuration. The truth table for these pins is shown below. If a driver output is enabled but not used (i.e. left open), the IC's open circuit-detection circuitry will operate. Please keep the unused pins open. The LEDEN terminals are pulled down internally in the IC, so if left open, the IC will recognize them as logic LO. However, they should be connected directly to VREG or fixed to a logic HI when in use.

LED EN		LED			
<1>	<2>	1	2	3	4
L	L	ON	ON	ON	ON
H	L	ON	ON	ON	OFF
L	H	ON	ON	OFF	OFF
H	H	ON	OFF	OFF	OFF

• Output current setting

LED current is computed via the following equation:

$$I_{LED} = \min[VDAC, VISET(=2.0V)] / RSET \times GAIN [A]$$

(min[VDAC, 2.0V] = the smaller value of either VDAC or VISET; GAIN = set by internal circuitry.)

In applications where an external signal is used for output current control, a control voltage in the range of 0.1 to 2.0 V can be connected on the VDAC pin to control according to the above equation. If an external control signal is not used, connect the VDAC pin to VREG (do not leave the pin open as this may cause the IC to malfunction). Also, do not switch individual channels on or off via the LEDEN pin while operating in PWM mode.

The following diagram illustrates the relation between I<sub>LED</sub> and GAIN.

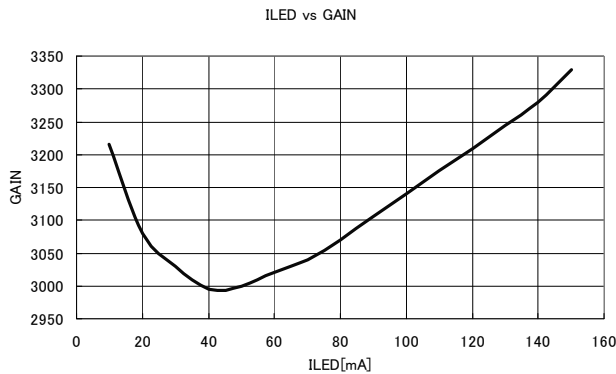

I <sub>LED</sub> [mA]	GAIN
10	3215
20	3080
30	3030
40	2995
50	3000
60	3020
70	3040
80	3070
90	3105
100	3140
110	3175
120	3210
130	3245
140	3280
150	3330

In PWM intensity control mode, the ON/OFF state of each current driver is controlled directly by the input signal on the PWM pin; thus, the duty ratio of the input signal on the PWM pin equals the duty ratio of the LED current. When not controlling intensity via PWM, fix the PWM terminal to a high voltage (100%). Output light intensity is greatest at 100% input.

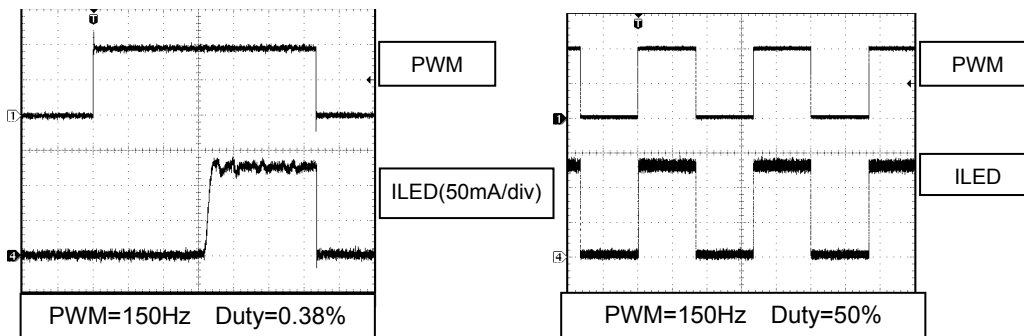

● Buck-Boost DC/DC controller

▪ Number of LEDs in series connection

Output voltage of the DCDC converter is controlled such that the forward voltage over each of the LEDs on the output is set to 1.0V (Typ.). DCDC operation is performed only when the LED output is operating. When two or more LED outputs are operating simultaneously, the LED voltage output is held at 1.0V (Typ.) per LED over the column of LEDs with the highest VF value. The voltages of other LED outputs are increased only in relation to the fluctuation of voltage over this column. Consideration should be given to the change in power dissipation due to variations in VF of the LEDs. Please determine the allowable maximum VF variance of the total LEDs in series by using the description as shown below:

VF variation allowable voltage 3.7V(Typ.) = short detecting voltage 4.7V(Typ.) - LED control voltage 1.0V(Typ.)

The number of LEDs that can be connected in series is limited due to the open-circuit protection circuit, which engages at 85% of the set OVP voltage. Therefore, the maximum output voltage of the under normal operation becomes 30.6 V (= 36 V x 0.85, where (30.6 V - 1.0 V) / VF > N [maximum number of LEDs in series]).

▪ Over-voltage protection circuit (OVP)

The output of the DCDC converter should be connected to the OVP pin via a voltage divider. In determining an appropriate trigger voltage of for OVP function, consider the total number of LEDs in series and the maximum variation in VF. Also, bear in mind that over-current protection (OCP) is triggered at 0.85 x OVP trigger voltage. If the OVP function engages, it will not release unless the DCDC voltage drops to 72.5% of the OVP trigger voltage. For example, if ROVP1 (output voltage side), ROVP2 (GND side), and DCDC voltage VOUT are conditions for OVP, then:

$VOUT \geq (ROVP1 + ROVP2) / ROVP2 \times 2.0 V$ .

OVP will engage when VOUT > 32 V if ROVP1 = 330 kΩ and ROVP2 = 22 kΩ.

▪ Buck-boost DC/DC converter oscillation frequency (FOSC)

The regulator's internal triangular wave oscillation frequency can be set via a resistor connected to the RT pin (pin 26). This resistor determines the charge/discharge current to the internal capacitor, thereby changing the oscillating frequency. Refer to the following theoretical formula when setting RT:

$$f_{osc} = \frac{30 \times 10^6}{RT [\Omega]} \times \alpha \text{ [kHz]}$$

30 x 10<sup>6</sup> (V/A/S) is a constant (±16.6%) determined by the internal circuitry, and α is a correction factor that varies in relation to RT: { RT: α = 50kΩ: 0.98, 60kΩ: 0.985, 70kΩ: 0.99, 80kΩ: 0.994, 90kΩ: 0.996, 100kΩ: 1.0, 50kΩ: 1.01, 200kΩ: 1.02, 300kΩ: 1.03, 400kΩ: 1.04, 500kΩ: 1.045 }

A resistor in the range of 62.6kΩ~523kΩ is recommended. Settings that deviate from the frequency range shown below may cause switching to stop, and proper operation cannot be guaranteed.

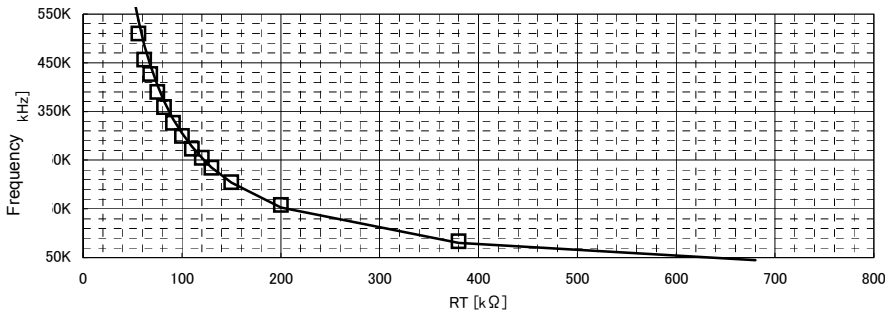

Fig.15 RT versus switching frequency

▪ External DC/DC converter oscillating frequency synchronization (FSYNC)

Do not switch from external to internal oscillation of the DC/DC converter if an external synchronization signal is present on the SYNC pin. When the signal on the SYNC terminal is switched from high to low, a delay of about 30 μS (typ.) occurs before the internal oscillation circuitry starts to operate (only the rising edge of the input clock signal on the SYNC terminal is recognized). Moreover, if external input frequency is less than the internal oscillation frequency, the internal oscillator will engage after the above-mentioned 30 μS (typ.) delay; thus, do not input a synchronization signal with a frequency less than the internal oscillation frequency.

### • Soft Start Function

The soft-start (SS) limits the current and slows the rise-time of the output voltage during the start-up, and hence leads to prevention of the overshoot of the output voltage and the inrush current.

### • Self-diagnostic functions

The operating status of the built-in protection circuitry is propagated to FAIL1 and FAIL2 pins (open-drain outputs). FAIL1 becomes low when UVLO, TSD, OVP, or SCP protection is engaged, whereas FAIL2 becomes low when open or short LED is detected.

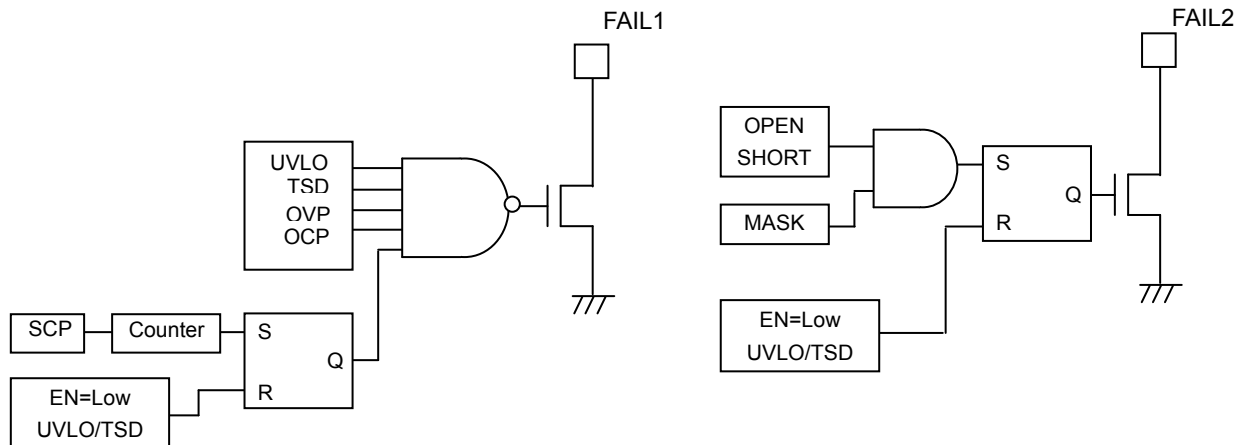

### • Operation of the Protection Circuitry

#### • Under-Voltage Lock Out (UVLO)

The UVLO shuts down all the circuits other than REG when  $V_{CC} \leq 4.3V$  (TYP).

#### • Thermal Shut Down (TSD)

The TSD shuts down all the circuits other than REG when the  $T_j$  reaches  $175^\circ C$  (TYP), and releases when the  $T_j$  becomes below  $150^\circ C$  (TYP).

#### • Over Current Protection (OCP)

The OCP detects the current through the power-FET by monitoring the voltage of the high-side resistor, and activates when the CS voltage becomes less than  $V_{CC}-0.6V$  (TYP).

When the OCP is activated, the external capacitor of the SS pin becomes discharged and the switching operation of the DCDC turns off.

#### • Over Voltage Protection (OVP)

The output voltage of the DCDC is detected with the OVP-pin voltage, and the protection activates when the OVP-pin voltage becomes greater than  $2.0V$  (TYP).

When the OVP is activated, the external capacitor of the SS pin becomes discharged and the switching operation of the DCDC turns off.

### • Short Circuit Protection (SCP)

When the LED-pin voltage becomes less than  $0.3V$  (TYP), the internal counter starts operating and latches off the circuit approximately after  $100ms$  (when  $F_{OSC} = 300kHz$ ). If the LED-pin voltage becomes over  $0.3V$  before  $100ms$ , then the counter resets.

When the LED anode (i.e. DCDC output voltage) is shorted to ground, then the LED current becomes off and the LED-pin voltage becomes low. Furthermore, the LED current also becomes off when the LED cathode is shorted to ground. Hence in summary, the SCP works with both cases of the LED anode and the cathode being shorted.

### • LED Open Detection

When the LED-pin voltage  $\leq 0.3V$  (TYP) as well as OVP-pin voltage  $\geq 1.7V$  (TYP) simultaneously, the device detects as LED open and latches off that particular channel.

- LED Short Detection

When the LED-pin voltage  $\geq 4.7V$  (TYP) as well as OVP-pin voltage  $\leq 1.6V$  (TYP) simultaneously the internal counter starts operating, and approximately after 100ms (when FOSC = 300kHz) the only detected channel (as LED short) latches off. With the PWM brightness control, the detecting operation is processed only when PWM-pin = High. If the condition of the detection operation is released before 100ms (when FOSC = 300kHz), then the internal counter resets.

※ The counter frequency is the DCDC switching frequency determined by the RT. The latch proceeds at the count of 32770.

Protection	Detecting Condition		Operation after detect
	[Detect]	[Release]	
UVLO	VREG<4.3V	VREG>4.5V	All blocks shut down
TSD	Tj>175°C	Tj<150°C	All blocks (but except REG) shut down
OVP	VOVP>2.0V	VOVP<1.45V	SS discharged
OCP	VCS $\leq$ VCC-0.6V	VCS>VCC-0.6V	SS discharged
SCP	VLED<0.3V (100ms delay when FOSC=300kHz)	EN or UVLO	Counter starts and then latches off all blocks (but except REG)
LED open	VLED<0.3V & VOVP>1.7V	EN or UVLO	The only detected channel latches off
LED short	VLED>4.7V & VOVP<1.6V (100ms delay when FOSC=300kHz)	EN or UVLO	The only detected channel latches off (after the counter sets)

●Protection Sequence

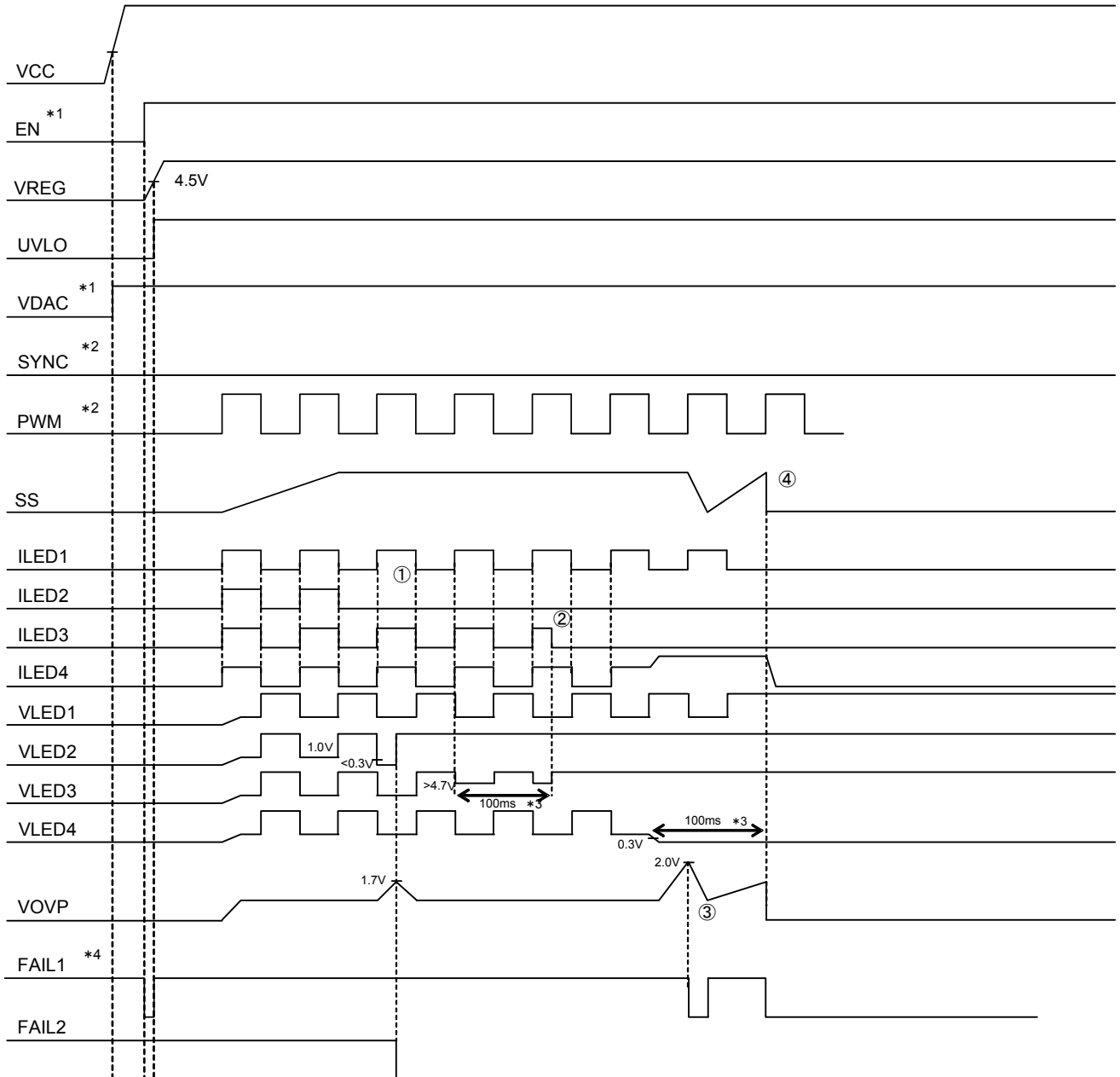

- \* 1 Turn on the EN after the VCC is on
- \* 2 SYNC and PWM inputs are allowed to be on before the VCC is on
- \* 3 Approx 100ms of delay when Fosc = 300kHz

- ① Case for LED2 in open-mode  
When  $VLED2 < 0.3V$  and  $VOVP > 1.7V$  simultaneously, then LED2 becomes off and FAIL2 becomes low
- ② Case for LED3 in short-mode  
When  $VLED3 > 4.7V$  and  $VOVP < 1.6V$  simultaneously, then LED3 becomes off after 100ms approx
- ③ Case for LED4 in short to GND
  - ③-1 DCDC output voltage increases, and then SS discharges and FAIL1 becomes low
  - ③-2 Detects  $VLED4 < 0.3V$  and shuts down after 100ms approx

**● Procedure for external components selection**

Follow the steps as shown below for selecting the external components

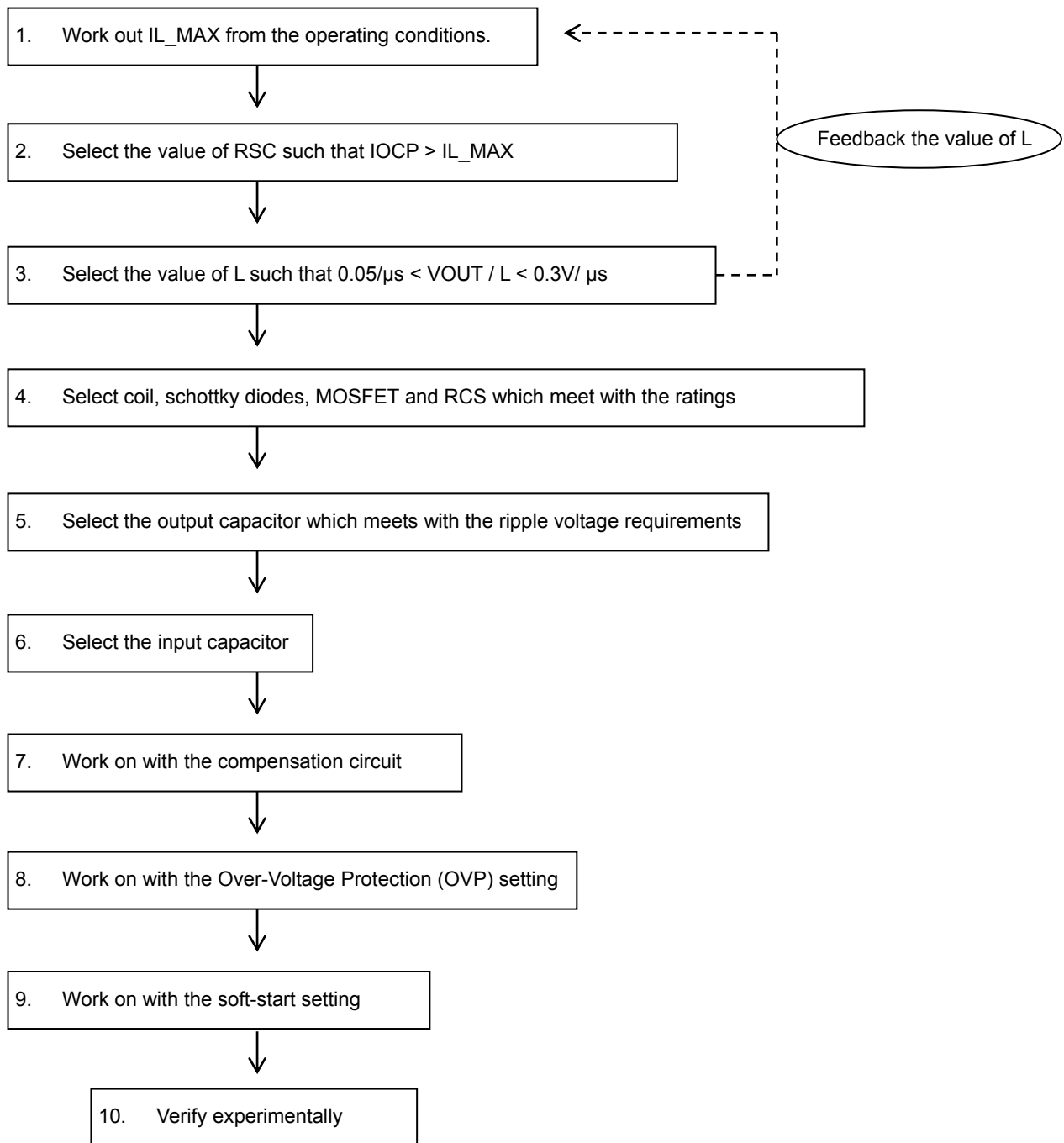

## 1. Computation of the Input Peak Current and IL\_MAX

## ① Calculation of the maximum output voltage (Vout\_max)

To calculate the Vout\_max, it is necessary to take into account of the VF variation and the number of LED connection in series.

$$V_{out\_max} = (VF + \Delta VF) \times N + 1.0V$$

$\Delta VF$ : VF Variation    N: Number of LED connection in series

## ② Calculation of the output current Iout

$$I_{out} = I_{LED} \times 1.05 \times M$$

Number of LED connection in parallel

## ③ Calculation of the input peak current IL\_MAX

$$I_{L\_MAX} = I_{L\_AVG} + 1/2 \Delta I_L$$

$$I_{L\_AVG} = (V_{IN} + V_{out}) \times I_{out} / (n \times V_{IN})$$

$$\Delta I_L = \frac{V_{IN}}{L} \times \frac{1}{F_{osc}} \times \frac{V_{out}}{V_{IN} + V_{out}} \quad n: \text{efficiency} \quad F_{osc}: \text{switching frequency}$$

- The worst case scenario for VIN is when it is at the minimum, and thus the minimum value should be applied in the equation.
- The L value of 10 $\mu$ F ~ 47 $\mu$ F is recommended. The current-mode type of DC/DC conversion is adopted for BD8119FM-M, which is optimized with the use of the recommended L value in the design stage. This recommendation is based upon the efficiency as well as the stability. The L values outside this recommended range may cause irregular switching waveform and hence deteriorate stable operation.
- n (efficiency) is approximately 80%

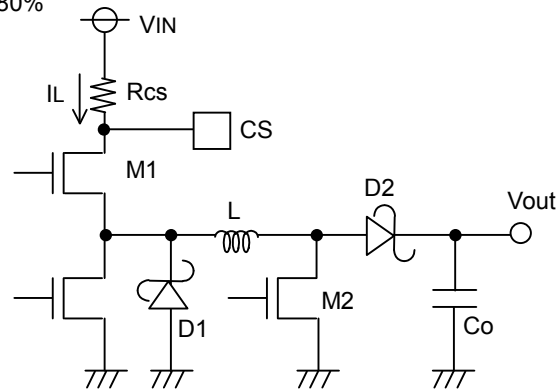

External Application Circuit

## 2. The setting of over-current protection

Choose Rcs with the use of the equation  $V_{ocp\_min} (=0.54V) / R_{cs} > I_{L\_MAX}$

When investigating the margin, it is worth noting that the L value may vary by approximately  $\pm 30\%$ .

## 3. The selection of the L

In order to achieve stable operation of the current-mode DC/DC converter, we recommend selecting the L value in the range indicated below:

$$0.05 [V/\mu S] < \frac{V_{out} \times R_{cs}}{L} < 0.3 [V/\mu S]$$

The smaller  $\frac{V_{out} \times R_{cs}}{L}$  allows stability improvement but slows down the response time.

## 4. Selection of coil L, diode D1 and D2, MOSFET M1 and M2, and Rcs

	Current rating	Voltage rating	Heat loss
Coil L	> IL_MAX	—	
Diode D1	> Iocp	> VIN_MAX	
Diode D2	> Iocp	> Vout	
MOSFET M1	> Iocp	> VIN_MAX	
MOSFET M2	> Iocp	> Vout	
Rcs	—	—	> Iocp <sup>2</sup> × Rcs

※ Allow some margin, such as the tolerance of the external components, when selecting.

※ In order to achieve fast switching, choose the MOSFETs with the smaller gate-capacitance.

### 5. Selection of the output capacitor

Select the output capacitor  $C_{out}$  based on the requirement of the ripple voltage  $V_{pp}$ .

$$V_{pp} = \frac{I_{out}}{C_{out}} \times \frac{V_{out}}{V_{out}+V_{IN}} \times \frac{1}{F_{osc}} + I_{L\_MIN} \times RESR$$

Choose  $C_{out}$  that allows the  $V_{pp}$  to settle within the requirement. Allow some margin also, such as the tolerance of the external components.

### 6. Selection of the input capacitor

A capacitor at the input is also required as the peak current flows between the input and the output in DC/DC conversion. We recommend an input capacitor greater than  $10\mu\text{F}$  with the ESR smaller than  $100\text{m}\Omega$ . The input capacitor outside of our recommendation may cause large ripple voltage at the input and hence lead to malfunction.

### 7. Phase Compensation Guidelines

In general, the negative feedback loop is stable when the following condition is met:

- Overall gain of 1 (0dB) with a phase lag of less than  $150^\circ$  (i.e., a phase margin of  $30^\circ$  or more)

However, as the DC/DC converter constantly samples the switching frequency, the gain-bandwidth (GBW) product of the entire series should be set to 1/10 the switching frequency of the system. Therefore, the overall stability characteristics of the application are as follows:

- Overall gain of 1 (0dB) with a phase lag of less than  $150^\circ$  (i.e., a phase margin of  $30^\circ$  or more)
- GBW (frequency at gain 0dB) of 1/10 the switching frequency

Thus, to improve response within the GBW product limits, the switching frequency must be increased.

The key for achieving stability is to place  $f_z$  near to the GBW.

$$\text{Phase-lead } f_z = \frac{1}{2\pi C_{pc}R_{pc}} \quad [\text{Hz}]$$

$$\text{Phase-lag } f_{p1} = \frac{1}{2\pi R_L C_{out}} \quad [\text{Hz}]$$

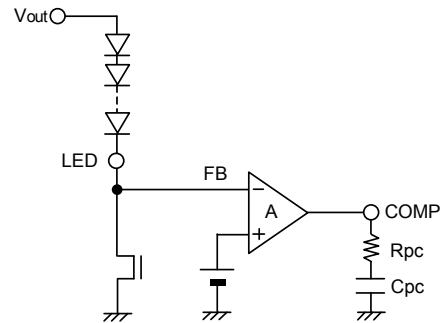

Good stability would be obtained when the  $f_z$  is set between  $1\text{kHz} \sim 10\text{kHz}$ .

In buck-boost applications, Right-Hand-Plane (RHP) Zero exists. This Zero has no gain but a pole characteristic in terms of phase. As this Zero would cause instability when it is in the control loop, so it is necessary to bring this zero before the GBW.

$$f_{RHP} = \frac{V_{out}+V_{IN}}{2\pi I_{LOAD}L} \quad [\text{Hz}] \quad I_{LOAD}: \text{Maximum Load Current}$$

It is important to keep in mind that these are very loose guidelines, and adjustments may have to be made to ensure stability in the actual circuitry. It is also important to note that stability characteristics can change greatly depending on factors such as substrate layout and load conditions. Therefore, when designing for mass-production, stability should be thoroughly investigated and confirmed in the actual physical design.

### 8. Setting of the over-voltage protection

We recommend setting the over-voltage protection  $V_{ovp}$  1.2V to 1.5V greater than  $V_{out}$  which is adjusted by the number of LEDs in series connection. Less than 1.2V may cause unexpected detection of the LED open and short during the PWM brightness control. For the  $V_{ovp}$  greater than 1.5V, the LED short detection may become invalid.

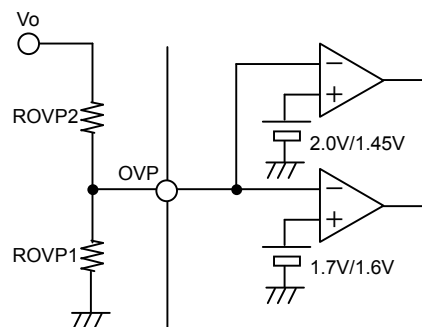

### 9. Setting of the soft-start

The soft-start allows minimization of the coil current as well as the overshoot of the output voltage at the start-up.

For the capacitance we recommend in the range of 0.001 ~ 0.1 $\mu$ F. For the capacitance less than 0.001 $\mu$ F may cause overshoot of the output voltage. For the capacitance greater than 0.1 $\mu$ F may cause massive reverse current through the parasitic elements of the IC and damage the whole device. In case it is necessary to use the capacitance greater than 0.1 $\mu$ F, ensure to have a reverse current protection diode at the Vcc or a bypass diode placed between the SS-pin and the Vcc.

Soft-start time TSS

$$TSS = CSS \times 0.7V / 5\mu A [s]$$

CSS: The capacitance at the SS-pin

### 10 Verification of the operation by taking measurements

The overall characteristic may change by load current, input voltage, output voltage, inductance, load capacitance, switching frequency, and the PCB layout. We strongly recommend verifying your design by taking the actual measurements.

●Power Dissipation Calculation

Power dissipation can be calculated as follows:

$$Pc(N) = ICC \cdot VCC + 2 \cdot Ciss \cdot VREG \cdot Fsw \cdot Vcc + [VLED \cdot N + \Delta Vf \cdot (N-1)] \cdot ILED$$

- ICC Maximum circuit current
- VCC Supply power voltage
- Ciss External FET capacitance
- Vsw SW gate voltage
- Fsw SE frequency
- VLED LED control voltage
- N LED parallel numeral
- ΔVf LED Vf fluctuation
- ILED LED output current

Sample Calculation:

$$Pc(4) = 10mA \times 30V + 500pF \times 5V \times 300kHz \times 30V + [1.0V \times 4 + \Delta Vf \times 3] \times 100mA$$

$$\Delta Vf = 3.0V, Pc(4) = 322.5mW + 1.3W = 1622.5mW$$

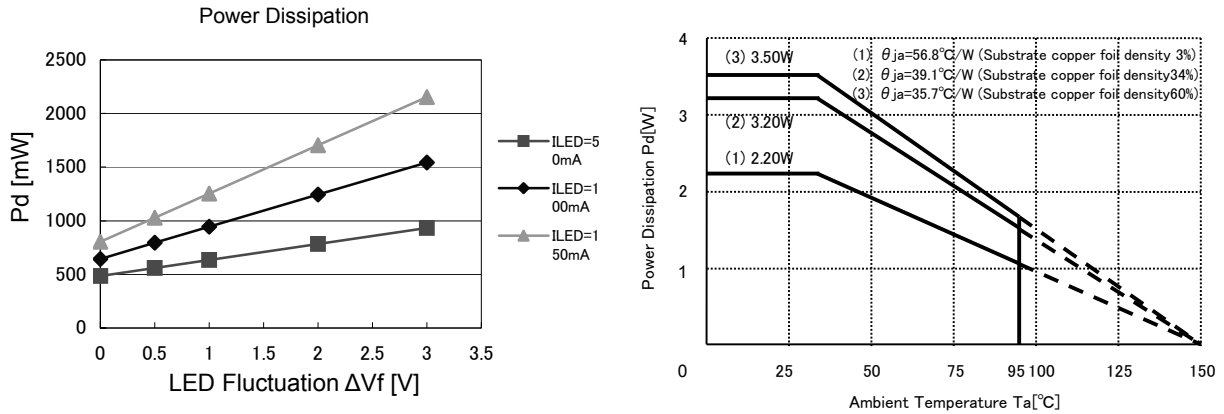

Fig.16

Note 1: Power dissipation calculated when mounted on 70mm X 70mm X 1.6mm glass epoxy substrate (1-layer platform/copper thickness 18μm)

Note 2: Power dissipation changes with the copper foil density of the board.

The area of the copper foil becomes the total area of the heat radiation fin and the foot pattern (connected directly with IC) of this IC. This value represents only observed values, not guaranteed values.

Pd=2200mW ( 968mW): Substrate copper foil density 3%

Pd=3200mW (1408mW): Substrate copper foil density 34%

Pd=3500mW (1540mW): Substrate copper foil density 60% (Value within parentheses represents power dissipation when Ta=95°C)

Note 3: Please design so that ambient temperature + self-generation of heat may become 150°C or less because this IC is Tj=150°C.

Note 4: Please note the heat design because there is a possibility that thermal resistance rises from the examination result of the temperature cycle by 20% or less.

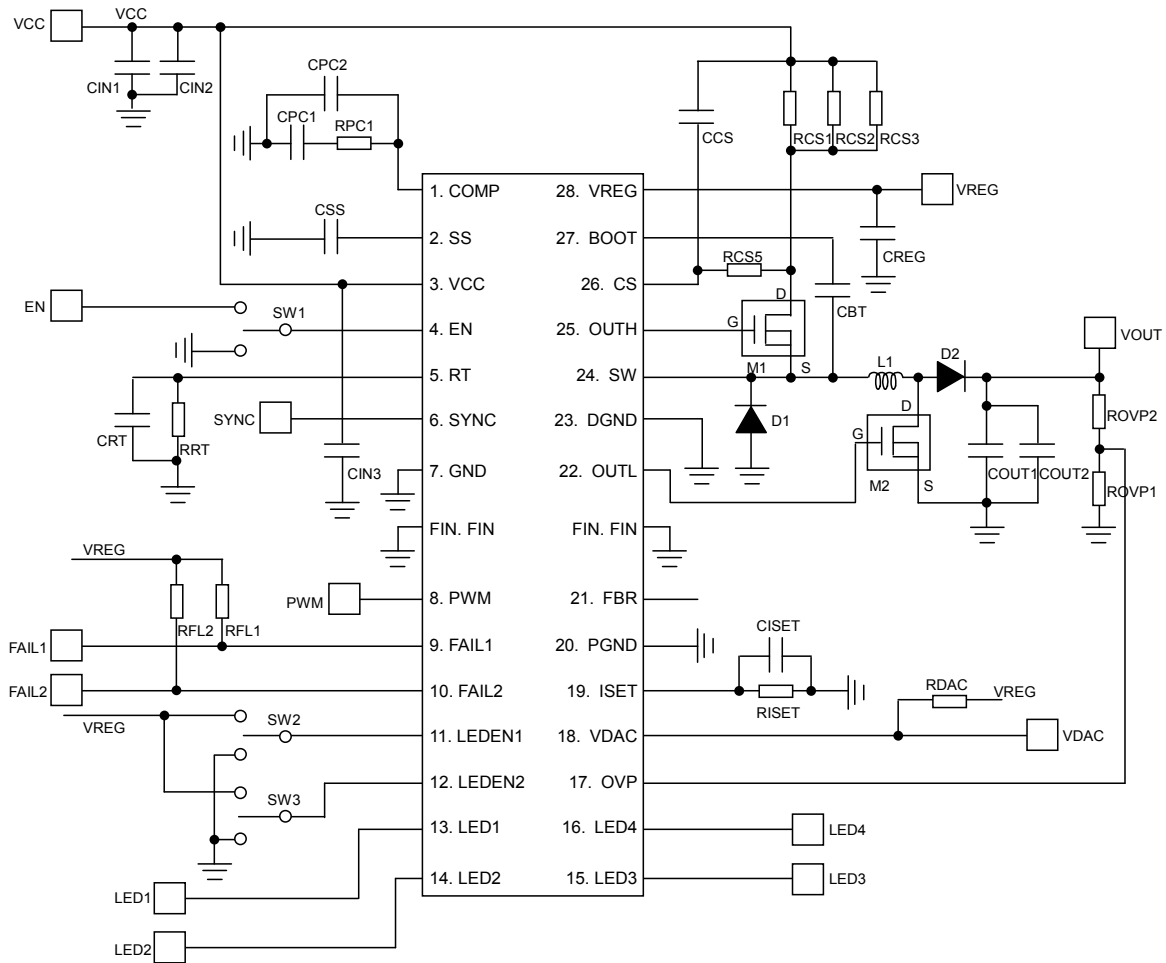

- The coupling capacitors CVCC and CREG should be mounted as close as possible to the IC's pins.
- Large currents may pass through DGND and PGND, so each should have its own low-impedance routing to the system ground.
- Noise should be minimized as much as possible on pins VDAC, ISET, RT and COMP.
- PWM, SYNC and LED1-4 carry switching signals, so ensure during layout that surrounding traces are not affected by crosstalk.

## ●Application Board Part List

serial No.	component name	component value	product name	Manufacturer
1	CIN1	10 $\mu$ F	GRM31CB31E106KA75B	murata
2	CIN2	—		
3	CIN3	—		
4	CPC1	0.1 $\mu$ F		
5	CPC2	—		murata
6	RPC1	510 $\Omega$		
7	CSS	0.1 $\mu$ F	GRM188B31H104KA92	murata
8	RRT	100k $\Omega$	MCR03 Series	Rohm
9	CRT	—		
10	RFL1	100k $\Omega$	MCR03 Series	Rohm
11	RFL2	100k $\Omega$	MCR03 Series	Rohm
12	CCS	—		
13	RCS1	620m $\Omega$	MCR100JZHFSR620	Rohm
14	RCS2	620m $\Omega$	MCR100JZHFSR620	Rohm
15	RCS3	—		
16	RCS5	0 $\Omega$		
17	CREG	2.2 $\mu$ F	GRM188B31A225KE33	murata
18	CBT	0.1 $\mu$ F	GRM188B31H104KA92	murata
19	M1	—	RSS070N05	Rohm
20	M2	—	RSS070N05	Rohm
21	D1	—	RB050L-40	Rohm
22	D2	—	RF201L2S	Rohm
23	L1	33 $\mu$ H	CDRH105R330	Sumida
24	COU1	10 $\mu$ F	GRM31CB31E106KA75B	murata
25	COU2	10 $\mu$ F	GRM31CB31E106KA75B	murata
26	ROVP1	30k $\Omega$	MCR03 Series	Rohm
27	ROVP2	360k $\Omega$	MCR03 Series	Rohm
28	RISSET	120k $\Omega$	MCR03 Series	Rohm
29	CISSET	—		
30	RDAC	0 $\Omega$		

- The above values are fixed numbers for confirmed operation with the following conditions:  $V_{CC} = 12V$ , four parallel channels of five series-connected LEDs, and  $I_{LED} = 50mA$ .
- Optimal values of external components depend on the actual application; these values should only be used as guidelines and should be adjusted to fit the operating conditions of the actual application.

When performing open/short tests of the external components, the open condition of D1 or D2 may cause permanent damage to the driver and/or the external components. In order to prevent this, we recommend having parallel connections for D1 and D2.

● Input/output Equivalent Circuits (terminal name follows pin number)

<p>1. COMP</p>	<p>2. SS</p>	<p>4. EN</p>
<p>5. RT</p>	<p>6. SYNC, 8. PWM</p>	<p>9. FAIL1, 10. FAIL2</p>
<p>11. LEDEN1, 12. LEDEN2</p>	<p>13. LED1, 14. LED2, 15. LED3, 16. LED4</p>	<p>17. OVP</p>
<p>18. VDAC</p>	<p>19. ISET</p>	<p>22. OUTL</p>
<p>24. SW</p>	<p>25. OUTH</p>	<p>26. CS</p>
<p>27. BOOT</p>	<p>28. VREG</p>	<p>21.</p> <p>N.C. = no connection (open)</p>

※All values typical.

## ●Notes for use

### 1) Absolute maximum ratings

Use of the IC in excess of absolute maximum ratings (such as the input voltage or operating temperature range) may result in damage to the IC. Assumptions should not be made regarding the state of the IC (e.g., short mode or open mode) when such damage is suffered. If operational values are expected to exceed the maximum ratings for the device, consider adding protective circuitry (such as fuses) to eliminate the risk of damaging the IC.

### 2) GND potential

Ensure that the GND pin is held at the minimum potential in all operating conditions.

### 3) Thermal Design

Use a thermal design that allows for a sufficient margin for power dissipation ( $P_d$ ) under actual operating conditions.

### 4) Inter-pin shorts and mounting errors

Use caution when orienting and positioning the IC for mounting on printed circuit boards. Improper mounting may result in damage to the IC. Shorts between output pins or between output pins and the power supply and GND pins caused by poor soldering or foreign objects may result in damage to the IC.

### 5) Operation in strong electromagnetic fields

Exercise caution when using the IC in the presence of strong electromagnetic fields as doing so may cause the IC to malfunction.

### 6) Testing on application boards

When testing the IC on an application board, connecting a capacitor directly to a low-impedance pin may subject the IC to stress. Always discharge capacitors completely after each process or step. The IC's power supply should always be turned off completely before connecting or removing it from a jig or fixture during the evaluation process. To prevent damage from static discharge, ground the IC during assembly and use similar precautions during transport and storage.

### 7) Ground wiring patterns

When using both small-signal and large-current GND traces, the two ground traces should be routed separately but connected to a single ground potential within the application in order to avoid variations in the small-signal ground caused by large currents. Also ensure that the GND traces of external components do not cause variations on GND voltage.

### 8) IC input pins and parasitic elements

This monolithic IC contains P+ isolation and P substrate layers between adjacent elements in order to keep them isolated. PN junctions are formed at the intersection of these P layers with the N layers of other elements, creating parasitic diodes and/or transistors. For example (refer to the figure below):

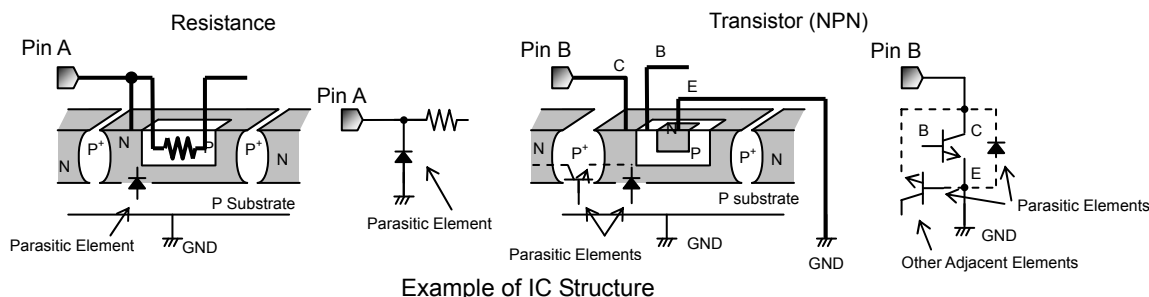

- When  $GND > Pin A$  and  $GND > Pin B$ , the PN junction operates as a parasitic diode
- When  $GND > Pin B$ , the PN junction operates as a parasitic transistor

Parasitic diodes occur inevitably in the structure of the IC, and the operation of these parasitic diodes can result in mutual interference among circuits, operational faults, or physical damage. Accordingly, conditions that cause these diodes to operate, such as applying a voltage lower than the GND voltage to an input pin (and thus to the P substrate) should be avoided.

### 9) Over-current protection circuits

An over-current protection circuit (designed according to the output current) is integrated into the IC to prevent damage in the event of load shorting. This protection circuit is effective in preventing damage due to sudden and unexpected overloads on the output. However, the IC should not be used in applications where operation of the OCP function is anticipated or assumed.

### 10) Thermal shutdown circuit (TSD)

This IC also incorporates a built-in TSD circuit for the protection from thermal destruction. The IC should be used within the specified power dissipation range. However, in the event that the IC continues to be operated in excess of its power dissipation limits, the rise in the chip's junction temperature  $T_j$  will trigger the TSD circuit, shutting off all output power elements. The circuit automatically resets itself once the junction temperature  $T_j$  drops down to normal operating temperatures. The TSD protection will only engage when the IC's absolute maximum ratings have been exceeded; therefore, application designs should never attempt to purposely make use of the TSD function.

●Ordering part number

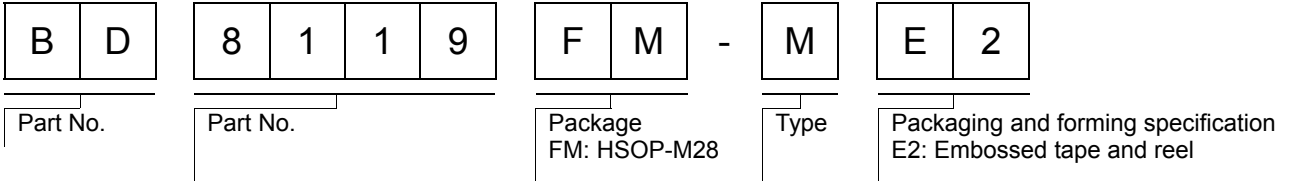

HSOP-M28

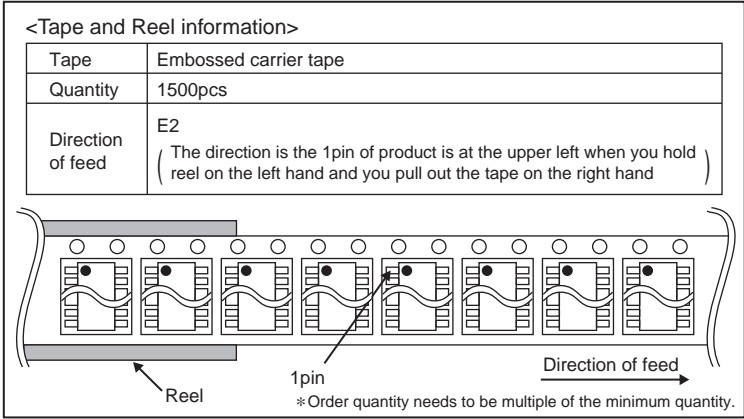
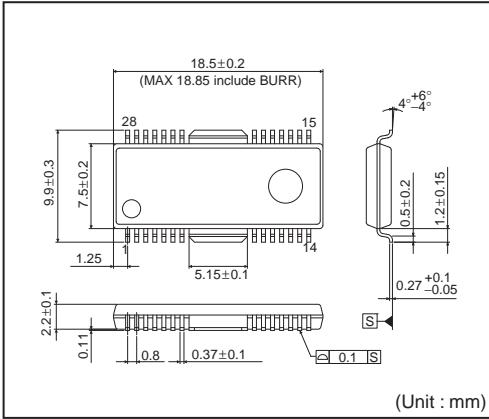

## Notes

No copying or reproduction of this document, in part or in whole, is permitted without the consent of ROHM Co.,Ltd.

The content specified herein is subject to change for improvement without notice.

The content specified herein is for the purpose of introducing ROHM's products (hereinafter "Products"). If you wish to use any such Product, please be sure to refer to the specifications, which can be obtained from ROHM upon request.

Examples of application circuits, circuit constants and any other information contained herein illustrate the standard usage and operations of the Products. The peripheral conditions must be taken into account when designing circuits for mass production.

Great care was taken in ensuring the accuracy of the information specified in this document. However, should you incur any damage arising from any inaccuracy or misprint of such information, ROHM shall bear no responsibility for such damage.

The technical information specified herein is intended only to show the typical functions of and examples of application circuits for the Products. ROHM does not grant you, explicitly or implicitly, any license to use or exercise intellectual property or other rights held by ROHM and other parties. ROHM shall bear no responsibility whatsoever for any dispute arising from the use of such technical information.

The Products specified in this document are intended to be used with general-use electronic equipment or devices (such as audio visual equipment, office-automation equipment, communication devices, electronic appliances and amusement devices).

The Products specified in this document are not designed to be radiation tolerant.

While ROHM always makes efforts to enhance the quality and reliability of its Products, a Product may fail or malfunction for a variety of reasons.

Please be sure to implement in your equipment using the Products safety measures to guard against the possibility of physical injury, fire or any other damage caused in the event of the failure of any Product, such as derating, redundancy, fire control and fail-safe designs. ROHM shall bear no responsibility whatsoever for your use of any Product outside of the prescribed scope or not in accordance with the instruction manual.

The Products are not designed or manufactured to be used with any equipment, device or system which requires an extremely high level of reliability the failure or malfunction of which may result in a direct threat to human life or create a risk of human injury (such as a medical instrument, transportation equipment, aerospace machinery, nuclear-reactor controller, fuel-controller or other safety device). ROHM shall bear no responsibility in any way for use of any of the Products for the above special purposes. If a Product is intended to be used for any such special purpose, please contact a ROHM sales representative before purchasing.

If you intend to export or ship overseas any Product or technology specified herein that may be controlled under the Foreign Exchange and the Foreign Trade Law, you will be required to obtain a license or permit under the Law.



Thank you for your accessing to ROHM product informations.  
More detail product informations and catalogs are available, please contact us.

## ROHM Customer Support System

<http://www.rohm.com/contact/>