

The accessory IC series for the video



Video isolation amplifier

BH7673G

No.12069EAT01

•General

BH7673G is the single isolation video amplifier. It can reject the external noise when it receives the signal outside of the application. It can reduce the influence of the external noise substantially. Because it has high common mode noise rejection ratio (-60dB Typ.). It is the best for the application of automotives, because it is able to use a wide range of temperature and it has the high electrostatic discharge rating. Moreover, because the frequency characteristic can correspond to the Hi-Vision signal, it is at the development to equal to or more than 30 MHz.

•Features

- 1) The high Electrostatic discharge(ESD) rating (The human body model: $\pm 6000V$ pass)
- 2) Able to use a wide range of temperature, from $-40^{\circ}C$ to $+85^{\circ}C$
- 3) High common mode rejection ratio(Typ. -60dB, $f=20kHz$)
- 4) It is not the degradation of CMRR when inserting ESD resistance at the input terminal.
- 5) Wide band [suitable for D4 standard] (0dB at $f=30MHz$)
- 6) Wide output dynamic range(Typ. 3.8Vpp)
- 7) High input Impedance(Typ. 150k Ω)
- 8) Low circuit current consumption(Typ. 4.8mA)
- 9) Bias input
- 10) SSOP5 small package

•Applications

The car navigation systems, the car monitor etc.

The signal input to the rear monitor, the picture taking-in from the rear camera and the measure of the noise when pulling around a video signal out of the substrate.

•Absolute Maximum Ratings (Ta=25°C)

Parameter	Symbol	Limits	Unit
Supply voltage	VCC	7.0	V
Power dissipation	Pd	540 * ¹	mW
Input voltage range	V _{IN}	0~VCC+0.2	V
Operating temperature	Topr	-40~+85	°C
Storage temperature	Tstg	-55~+125	°C

* Reduced by 5.4mW/°C at 25°C or higher
When mounting on a 70mmX70mmX1.6mm PCB board.

•Operating Condition (Ta=25°C)

Parameter	Symbol	Min.	Typ.	Max	Unit
Supply voltage	VCC	4.5	5.0	5.5	V

* This product is not designed for protection against radioactive rays.

●Electrical characteristics (Unless otherwise specified, Ta= 25°C, VCC=5.0V)

Parameter	Symbol	Min.	Typ.	Max.	Unit	Conditions
Circuit current	ICC	—	4.8	8.0	mA	No signal
Maximum output level	V _{OM}	3.2	3.8	—	V _{pp}	f=10kHz, THD=1.0%
Voltage gain	G _V	-1.0	0.0	1.0	dB	V _{in} =1.0V _{pp} , f=1MHz
Frequency characteristics 1	G _{F1}	-1.0	0.0	1.0	dB	V _{in} =1.0V _{pp} , f=10MHz/1MHz
Frequency characteristics 2	G _{F2}	—	0.0	—	dB	V _{in} =1.0V _{pp} , f=30MHz/1MHz
Common mode rejection ratio	CMRR	—	-60	-40	dB	V _{in} =1.0V _{pp} , f=20kHz
Input Impedance	Z _{IN}	110	150	190	kΩ	
Differential gain	D _G	—	0.1	—	%	V _{in} =1.0V _{pp} , Standard stair step signal
Differential phase	D _P	—	0.3	—	deg.	V _{in} =1.0V _{pp} , Standard stair step signal
S/N _Y	S/N _Y	—	70	—	dB	V _{in} =1.0V _{pp} , bandwidth 100k~6MHz 100% white video signal
Electrostatic discharge rating (The human body model)	HBM	—	±6	—	kV	R=1.5kΩ, C=100pF

●Block diagram

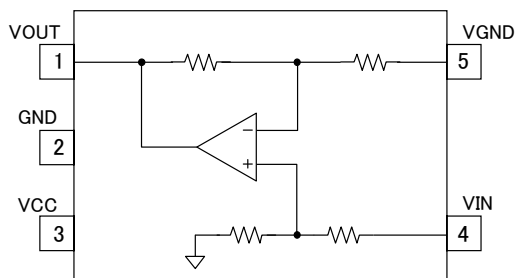

•I/O equivalent circuit diagrams

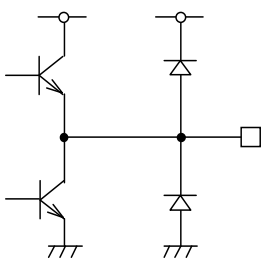
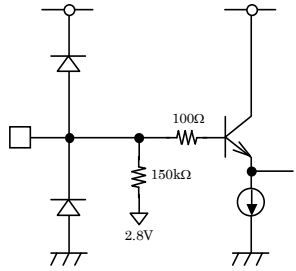
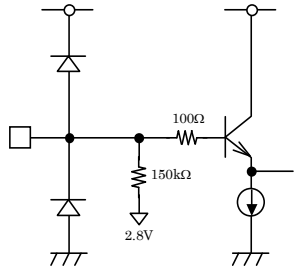
PIN	Name	Equivalent circuit	DC voltage	The function explanation
1	VOUT		2.1V	Video signal output pin. Use load resistance at equal to or more than 2 kΩ.
2	GND	—	0V	GND pin
3	VCC	—	5V	VCC pin
4	VIN		2.8V	Video signal input pin is used for bias type input. Input impedance is 150 kΩ.
5	VGND		2.8V	The bias type input. Input Impedance is 150kΩ

Note1) The above DC potential is only when VCC = 5V. This value is a reference value and is not guaranteed.

Note2) Numerical values shown in these figures are design values, and compliance to standards is not guaranteed.

● Test Circuit Diagrams

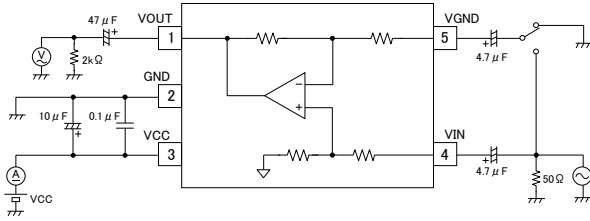

Fig.1 Test Circuit Diagram
Test circuit diagrams are used for shipment inspections, and differ from application circuits.

● Application circuit examples

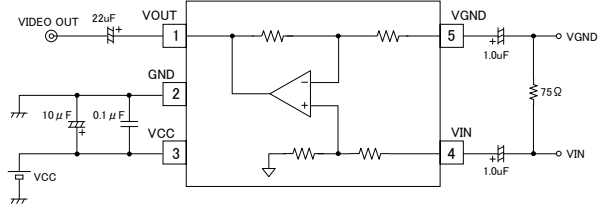

Fig.2 Application circuit examples
See pages 6 for description of how to determine the capacity of I/O coupling capacitors.

● Evaluation board pattern diagram and circuit diagram

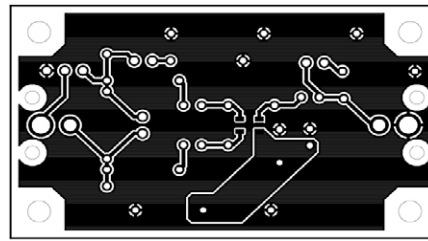
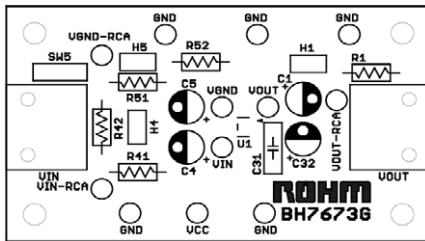

Fig.3 Evaluation Board Pattern Diagram

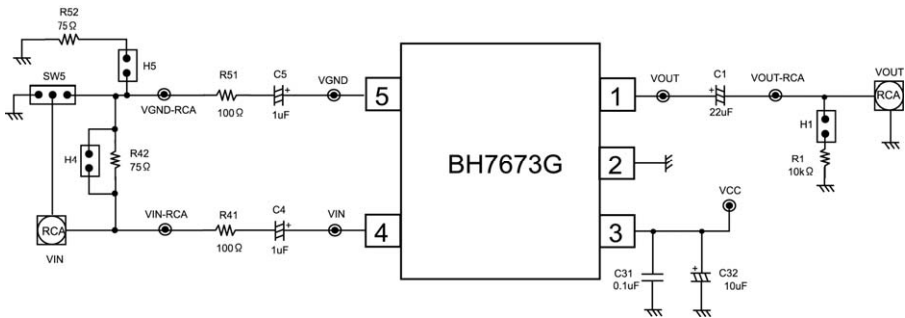

Fig.4 Evaluation Board Circuit Diagram

Parts list

Symbol	Function	Recommended value	Comments
R42 R52	Input terminating resistor	50Ω, 75Ω, 600Ω etc.	
R41 R51	Surge Resistance	unless 1kΩ	It adds according to the necessity.
C4 C5	Input coupling capacitor	1.0μF (See pages 6 to determine)	Recommended B characteristics
R1	The load resistance	2kΩ over	It is unnecessary when connecting output with the following paragraph IC.
C1	Output coupling capacitor	See pages 6 to determine	Recommended B characteristics
C32	Decoupling capacitor	10μF	Recommended B characteristics
C31		0.1μF	

● About the setting of a jumper switch

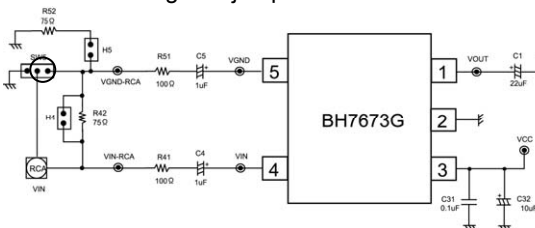

Fig.5 Generally, it is when evaluating.
Make SW5 connection H4 on the side of the circuit and make H5 OPEN.

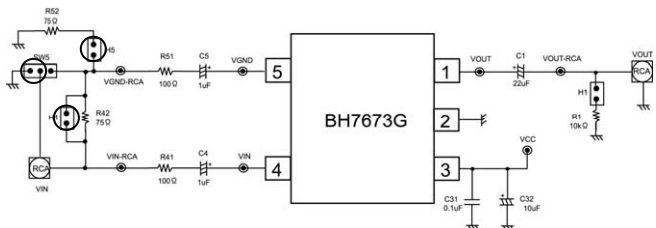

Fig.6 CMRR measurement
Make SW5 connection H4 at the circuit and on the opposite side and make H5 ON.

●Cautions for use

1. The numerical values and data shown here are typical design values, not guaranteed values.
2. The application circuit examples show recommended circuits, but characteristics should be checked carefully before using these circuits. If any external part constants are modified before use, factors such as variation in all external parts and ROHM LSI ICs, including not only static characteristics but also transient characteristics, should be fully considered to set an ample margin.
3. Absolute maximum ratings

If the absolute maximum ratings for applied voltage and/or operation temperature are exceeded, LSI damage may result. Therefore, do not apply voltage or use in a temperature that exceeds these absolute maximum ratings. If it is possible that absolute maximum ratings will be exceeded, use a physical safety device such as a fuse and make sure that no conditions that might exceed the absolute maximum ratings will be applied to the LSI IC.
4. GND potential

Regardless of the operation mode, the voltage of the GND pin should be at least the minimum voltage. Actually check whether or not the voltage at each pin, including transient phenomena, is less than the GND pin voltage.
5. Thermal design

The thermal design should be done using an ample margin that takes into consideration the allowable dissipation under actual use conditions.
6. Shorts between pins and mounting errors

When mounting LSI ICs onto the circuit board, make sure each LSI's orientation and position is correct. The ICs may become damaged if they are not mounted correctly when the power is turned on. Similarly, damage may also result if a short occurs, such as when a foreign object is positioned between pins in an IC, or between a pin and a power supply or GND connection
7. Operation in strong electromagnetic field

When used within a strong electromagnetic field, evaluate carefully to avoid the risk of operation faults
8. Place the power supply's decoupling capacitor as close as possible to the VCC pin (PIN 3) and GND pin (PIN 2).
9. The parasitic capacitance of the application board may cause the peak of the frequency characteristic response to occur at a high frequency. To lower the peak of the frequency characteristic, connect in series resistors having resistance of several dozen ohm to several hundred ohm as close as possible to the output pin.

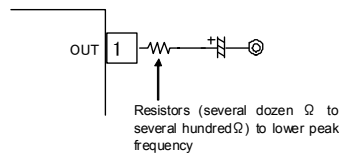

Fig.7 Positions where Resistors are Inserted to Lower Peak Frequency Response

10. The attention point when treating HD signal

As shown in reference data Fig.20, BH7673G have the frequency characteristic of equal to or more than 30 MHz but by the influence with the parasitic capacitance of the application board and so on, a characteristic as in the carrying data isn't sometimes gotten. The frequency characteristic can be improved in inserting about $2k\Omega \sim 3k\Omega$ resistance between the output terminal and the GND terminal to the case.

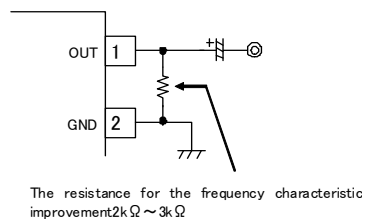

Fig.8 The resistance insertion position for the frequency characteristic improvement

●Cautions for selection and use of application parts

Method for determining capacity of input coupling capacitor

The input coupling capacitor and input impedance Z_{in} ($=150k\Omega$) inside the IC composes HPF.

When the cutoff frequency(f_c) of HPF takes from 1 Hz to be computed by the following formula (a). The value of the input coupling capacitor is computed with the degree as much as 1 μ F (Generally, the f_c takes from equal to or less than several Hz).

$$f_c = 1 / (2\pi \times C \times Z_{in}) \dots (a)$$

When evaluating the Sag characteristics and determining the capacity of the capacitor during video signal input, a horizontal stripe signal called "H bar" (shown in Fig.9) is suitable, and this type of signal is used instead of a color bar signal to evaluate characteristics and determine capacity.



Fig.9 Example of Screen with Obvious Sag (H-bar Signal)

Method for determining capacity of output coupling capacitor

The HPF is formed in the same way by the output coupling capacitor and the input impedance of the IC which connects with the following paragraph by the video output terminal, so estimate an output coupling capacitor with necessary capacity according to the formula (a).

The case of insert surge resistor at VIN and VGND terminals

Use the same value resistance when insert surge resistor(Fig.4 R41 and R51) at video input terminals(max value: 1k Ω). The degradation of CMRR etc are not deteriorating when inserting resistance with the same value.

● Reference data [Unless otherwise specified, VCC=5V, Ta=25°C]

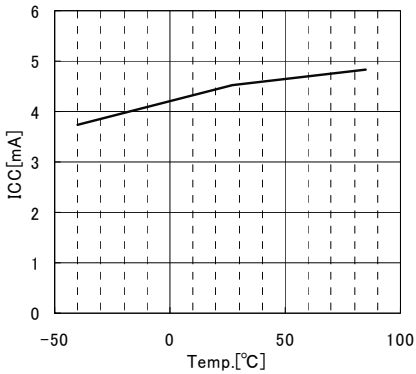

Fig.10
Circuit Current vs.
Ambient Temperature

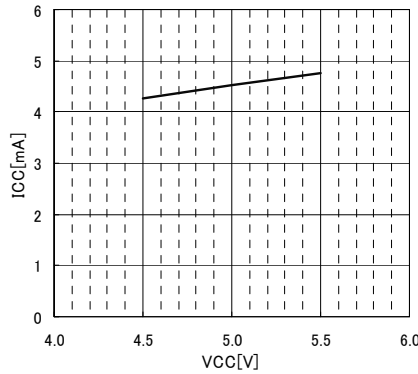

Fig.11
Circuit Current vs.
Supply Voltage

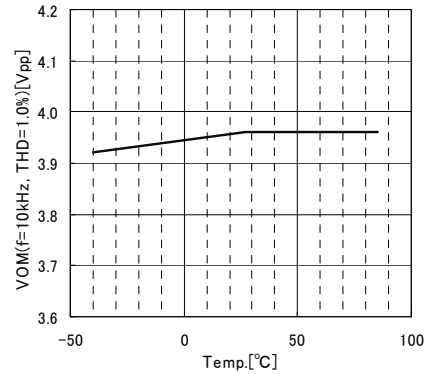

Fig.12
Maximum Output Level vs.
Ambient Temperature

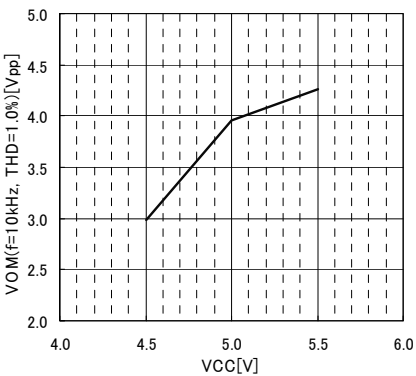

Fig.13
Maximum Output Level vs.
Supply Voltage

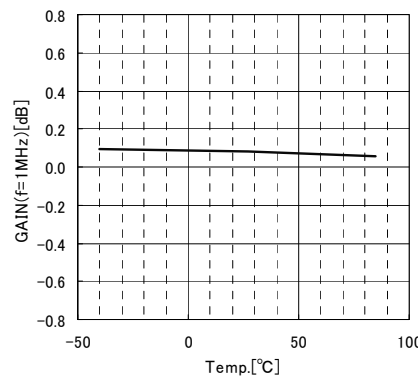

Fig.14
Gain vs.
Ambient Temperature

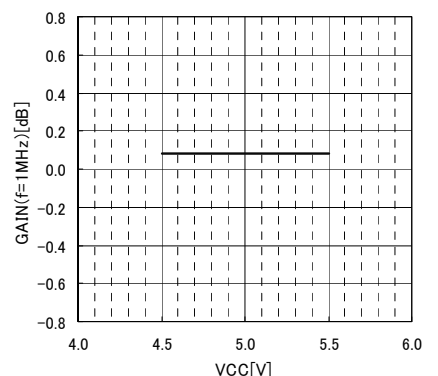

Fig.15
Gain vs.
Supply Voltage

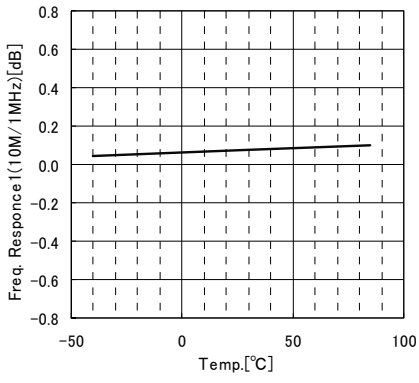

Fig. 16
Frequency Response1 vs.
Ambient Temperature

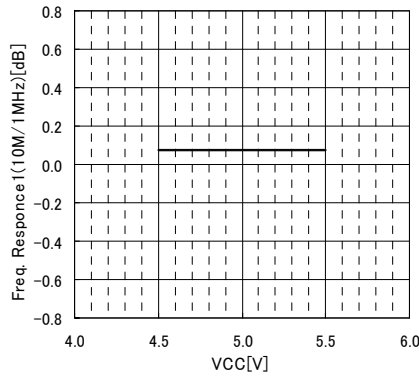

Fig. 17
Frequency Response1 vs.
Supply Voltage

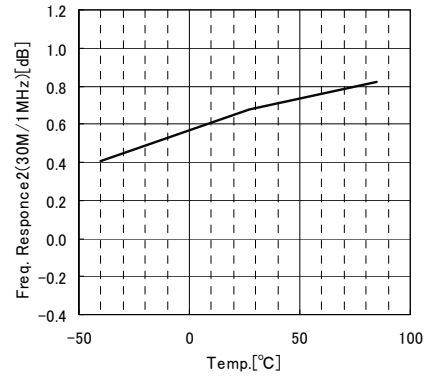

Fig. 18
Frequency Response2 vs.
Ambient Temperature

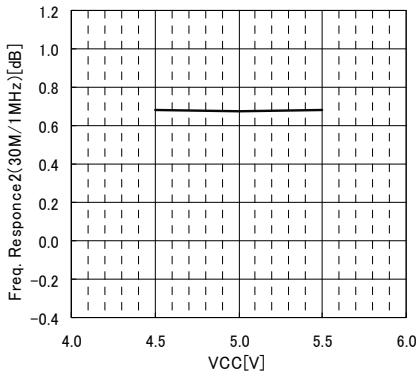

Fig. 19
Frequency Response2 vs.
Supply Voltage

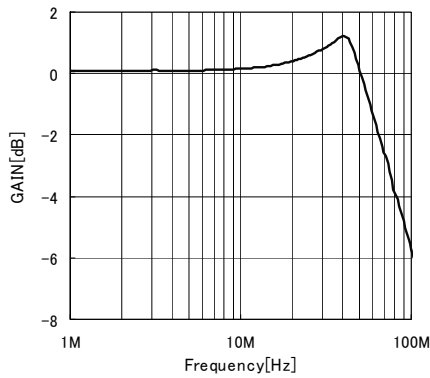

Fig. 20
Gain vs. Frequency

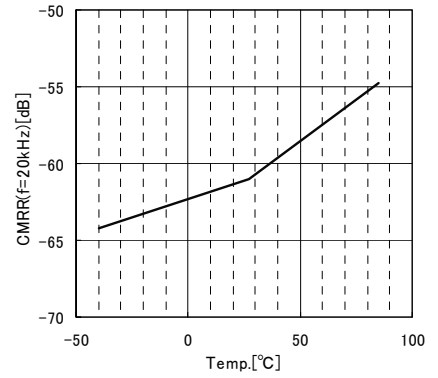

Fig. 21
Common Mode Rejection Ratio vs.
Ambient Temperature

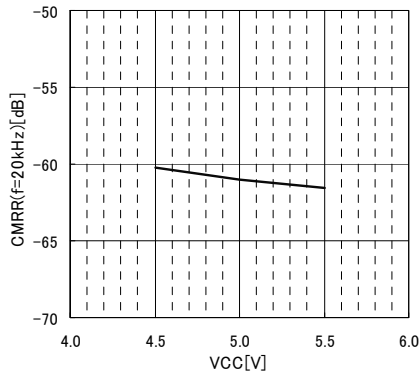

Fig. 22
Common Mode Rejection Ratio vs.
Supply Voltage

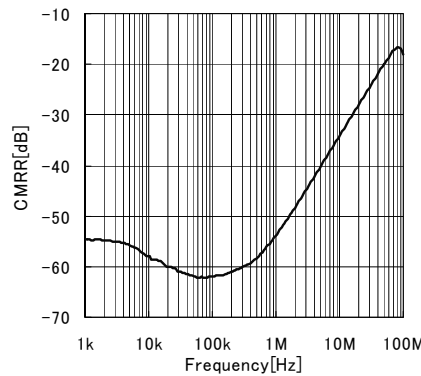

Fig. 23
Common Mode Rejection Ratio vs.
Frequency

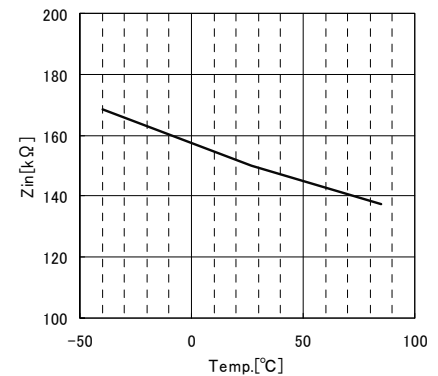

Fig. 24
Input Impedance vs.
Ambient Temperature

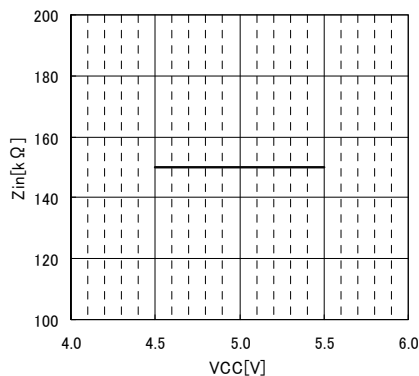

Fig. 25
Input Impedance vs.
Supply Voltage

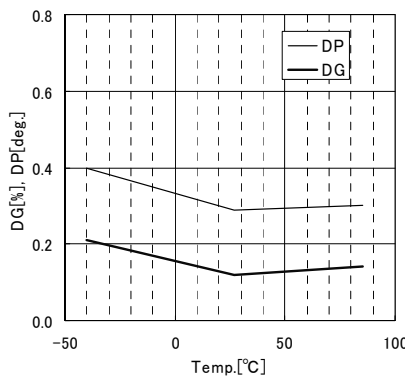

Fig. 26
Differential Gain & Differential Phase vs.
Ambient Temperature

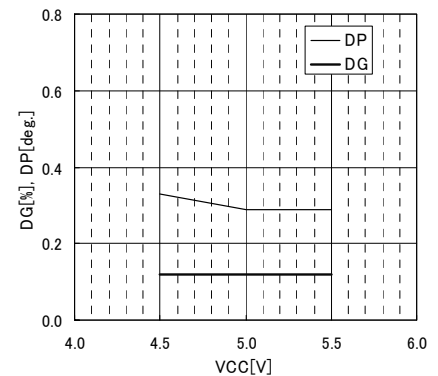

Fig. 27
Differential Gain & Differential Phase vs.
Supply Voltage

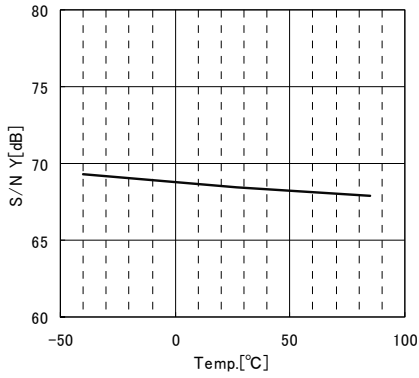

Fig.28
S/N Y vs.
Ambient Temperature

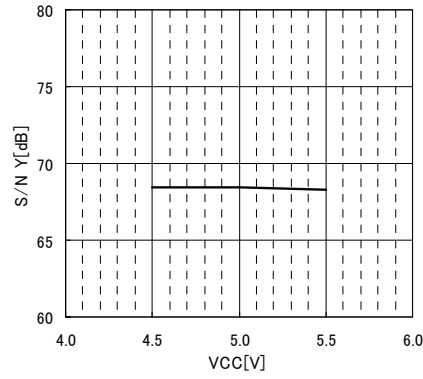

Fig.29
S/N Y vs.
Supply Voltage

•External dimensions and label codes

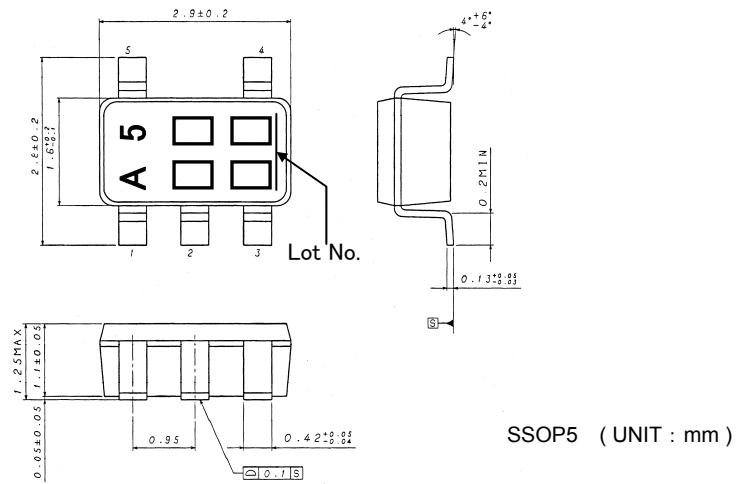
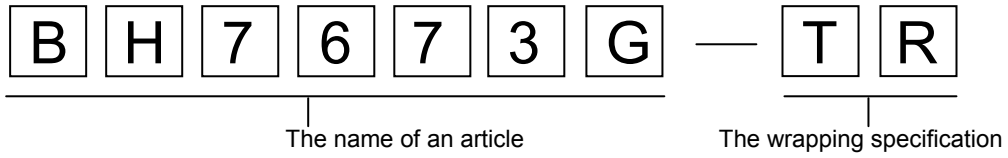
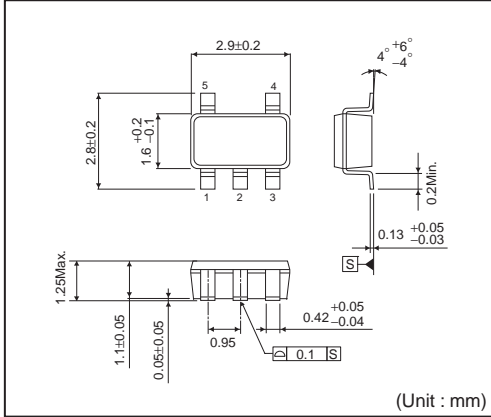

Fig.30 External Dimensions of BH7673G Package

•The ordering -shaped name selection



SSOP5



<Tape and Reel information>

Tape	Embossed carrier tape
Quantity	3000pcs
Direction of feed	TR (The direction is the 1 pin of product is at the upper right when you hold reel on the left hand and you pull out the tape on the right hand)

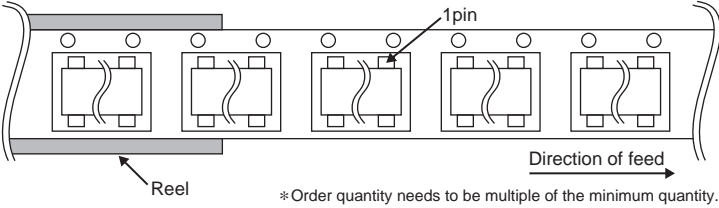

Notes

No copying or reproduction of this document, in part or in whole, is permitted without the consent of ROHM Co.,Ltd.

The content specified herein is subject to change for improvement without notice.

The content specified herein is for the purpose of introducing ROHM's products (hereinafter "Products"). If you wish to use any such Product, please be sure to refer to the specifications, which can be obtained from ROHM upon request.

Examples of application circuits, circuit constants and any other information contained herein illustrate the standard usage and operations of the Products. The peripheral conditions must be taken into account when designing circuits for mass production.

Great care was taken in ensuring the accuracy of the information specified in this document. However, should you incur any damage arising from any inaccuracy or misprint of such information, ROHM shall bear no responsibility for such damage.

The technical information specified herein is intended only to show the typical functions of and examples of application circuits for the Products. ROHM does not grant you, explicitly or implicitly, any license to use or exercise intellectual property or other rights held by ROHM and other parties. ROHM shall bear no responsibility whatsoever for any dispute arising from the use of such technical information.

The Products specified in this document are intended to be used with general-use electronic equipment or devices (such as audio visual equipment, office-automation equipment, communication devices, electronic appliances and amusement devices).

The Products specified in this document are not designed to be radiation tolerant.

While ROHM always makes efforts to enhance the quality and reliability of its Products, a Product may fail or malfunction for a variety of reasons.

Please be sure to implement in your equipment using the Products safety measures to guard against the possibility of physical injury, fire or any other damage caused in the event of the failure of any Product, such as derating, redundancy, fire control and fail-safe designs. ROHM shall bear no responsibility whatsoever for your use of any Product outside of the prescribed scope or not in accordance with the instruction manual.

The Products are not designed or manufactured to be used with any equipment, device or system which requires an extremely high level of reliability the failure or malfunction of which may result in a direct threat to human life or create a risk of human injury (such as a medical instrument, transportation equipment, aerospace machinery, nuclear-reactor controller, fuel-controller or other safety device). ROHM shall bear no responsibility in any way for use of any of the Products for the above special purposes. If a Product is intended to be used for any such special purpose, please contact a ROHM sales representative before purchasing.

If you intend to export or ship overseas any Product or technology specified herein that may be controlled under the Foreign Exchange and the Foreign Trade Law, you will be required to obtain a license or permit under the Law.



Thank you for your accessing to ROHM product informations.
More detail product informations and catalogs are available, please contact us.

ROHM Customer Support System

<http://www.rohm.com/contact/>