

Chip tantalum capacitors (Bottom surface electrode type)

TCT Series U Case

●Features (U)

- 1) Ultra-compact package
60% smaller footprint and 70% smaller volume than our conventional 1608(0603)-sized TCM series capacitors.
- 2) High capacitance : 1.0 μ F to 10 μ F
Ideal for coupling and noise reduction in audio circuits
- 3) High productivity, high reliability
Featuring the popular underside electrode configuration
- 4) Environmentally friendly halogen-free package

●Dimensions (Unit : mm)

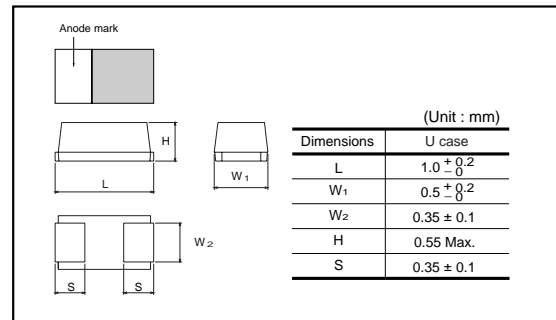

●Part No. Explanation

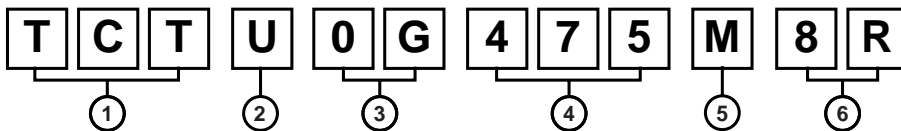

① Series name
TCT

② Case style
U

③ Rated voltage

Rated voltage (V)	2.5	4	6.3	10
CODE	0E	0G	0J	1A

④ Nominal capacitance
Nominal capacitance in pF in 3 digits:
2 significant figures followed by the figure
representing the number of 0's.

⑤ Capacitance tolerance
M : \pm 20%

⑥ Taping
8 : Tape width
R : Positive electrode on the side opposite to sprocket hole

Tantalum capacitors

● Rated table

(μF)	Rated voltage (V)			
	2.5 0E	4 0G	6.3 0J	10 1A
1.0 (105)			U	*U
1.5 (155)				
2.2 (225)			U	
3.3 (335)				
4.7 (475)		U		
6.8 (685)				
10 (106)	*U			
15 (156)				

Remark) Case size codes (U) in the above show products line-up.

* Under development

● Marking

The indications listed below should be given on the surface of a capacitor.

- (1) Polarity : The polarity should be shown by □ bar. (on the anode side)
- (2) Rated DC voltage : Due to the small size of U case, a voltage code is used as shown below.
- (3) Visual typical example (1) voltage code (2) capacitance code

Voltage Code	Rated DC Voltage (V)
e	2.5
g	4
j	6.3
A	10

Capacitance Code	Nominal Capacitance (μF)
A	1.0
J	2.2
S	4.7
a	10

[U case] note 1)

$\frac{g}{(1)}$ $\frac{S}{(2)}$



manufacture code

note 2) voltage code and capacitance code are variable with parts number

Tantalum capacitors

● Characteristics

Item	Performance	Test conditions (based on JIS C 5101-1 and JIS C 5101-3)
Operating Temperature	-55°C to +125°C	Voltage reduction when temperature exceeds +85°C
Maximum operating temperature with no voltage derating	+85°C	
Rated voltage (VDC)	2.5 4 6.3 10	at 85°C
Category voltage (VDC)	1.6 2.5 4 6.3	at 125°C
Surge voltage (VDC)	3.2 5.0 8 13	at 85°C
DC Leakage current	Shall be satisfied the voltage on " Standard list "	As per 4.9 JIS C 5101-1 As per 4.5.1 JIS C 5101-3 Voltage : Rated voltage for 5min
Capacitance tolerance	Shall be satisfied allowance range. ±20%	As per 4.7 JIS C 5101-1 As per 4.5.2 JIS C 5101-3 Measuring frequency : 120±12Hz Measuring voltage : 0.5Vrms +1.5 to 2V.DC Measuring circuit : DC Equivalent series circuit
Tangent of loss angle (Df, tan δ)	Shall be satisfied the voltage on " Standard list "	As per 4.8 JIS C 5101-1 As per 4.5.3 JIS C 5101-3 Measuring frequency : 120±12Hz Measuring voltage : 0.5Vrms +1.5 to 2V.DC Measuring circuit : DC Equivalent series circuit
Impedance	Shall be satisfied the voltage on " Standard list "	As per 4.10 JIS C 5101-1 As per 4.5.4 JIS C 5101-3 Measuring frequency : 100±10kHz Measuring voltage : 0.5Vrms or less Measuring circuit : DC Equivalent series circuit

● Standard products list, TCT series

Part No.	Rated voltage 85°C	Category voltage 125°C	Surge voltage 85°C	Cap. 120Hz	Tolerance (%)	Leakage current 25°C 1WV.5min (μA)	Df 120Hz (%)	ESR 100kHz
	(V)	(V)	(V)	(μF)			25°C 85°C	(Ω)
TCT U 0G 475□	4	2.5	5	4.7	±20	0.5	20	20
TCT U 0J 225□	6.3	4	8	2.2	±20	0.5	20	20

□=Tolerance (M : ±20%)

Tantalum capacitors

● Packaging specifications

Case code	A±0.1	B±0.1	W±0.2	E±0.1	F±0.05	P1±0.1	P2±0.1	P0±0.1
U	0.75	1.25	8.0	1.75	3.5	2.0	2.0	4.0

Case code	D ₀	t ₁ ±0.05	t ₂ ±0.1
U	φ1.55	0.20	0.60

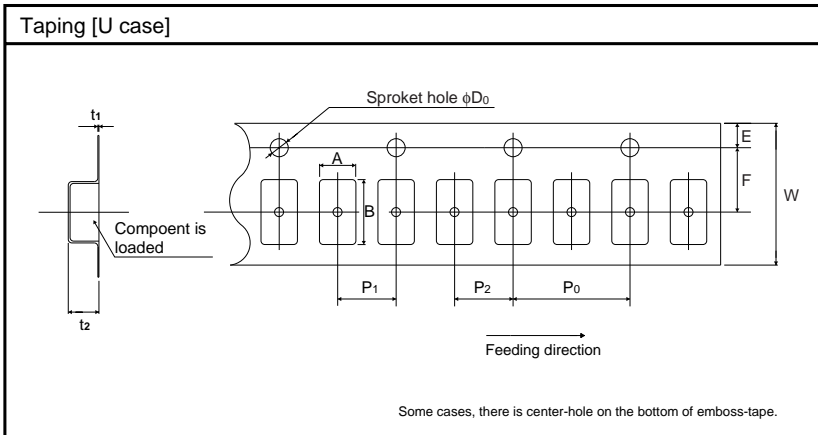

● Packaging style

Case code	Packaging	Packaging style		Symbol	Basic ordering units
U case	Taping	plastic taping	φ180mm Reel	R	10,000pcs

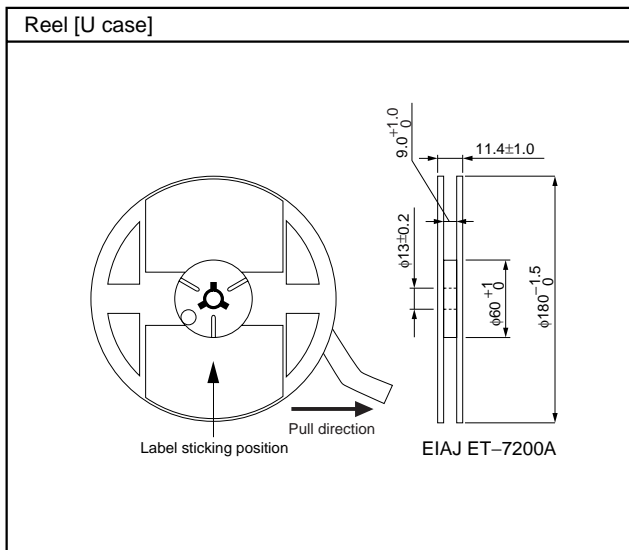

Notes

- No technical content pages of this document may be reproduced in any form or transmitted by any means without prior permission of ROHM CO.,LTD.
- The contents described herein are subject to change without notice. The specifications for the product described in this document are for reference only. Upon actual use, therefore, please request that specifications to be separately delivered.
- Application circuit diagrams and circuit constants contained herein are shown as examples of standard use and operation. Please pay careful attention to the peripheral conditions when designing circuits and deciding upon circuit constants in the set.
- Any data, including, but not limited to application circuit diagrams information, described herein are intended only as illustrations of such devices and not as the specifications for such devices. ROHM CO.,LTD. disclaims any warranty that any use of such devices shall be free from infringement of any third party's intellectual property rights or other proprietary rights, and further, assumes no liability of whatsoever nature in the event of any such infringement, or arising from or connected with or related to the use of such devices.
- Upon the sale of any such devices, other than for buyer's right to use such devices itself, resell or otherwise dispose of the same, no express or implied right or license to practice or commercially exploit any intellectual property rights or other proprietary rights owned or controlled by
- ROHM CO., LTD. is granted to any such buyer.
- Products listed in this document are no antiradiation design.

The products listed in this document are designed to be used with ordinary electronic equipment or devices (such as audio visual equipment, office-automation equipment, communications devices, electrical appliances and electronic toys).

Should you intend to use these products with equipment or devices which require an extremely high level of reliability and the malfunction of which would directly endanger human life (such as medical instruments, transportation equipment, aerospace machinery, nuclear-reactor controllers, fuel controllers and other safety devices), please be sure to consult with our sales representative in advance.

It is our top priority to supply products with the utmost quality and reliability. However, there is always a chance of failure due to unexpected factors. Therefore, please take into account the derating characteristics and allow for sufficient safety features, such as extra margin, anti-flammability, and fail-safe measures when designing in order to prevent possible accidents that may result in bodily harm or fire caused by component failure. ROHM cannot be held responsible for any damages arising from the use of the products under conditions out of the range of the specifications or due to non-compliance with the NOTES specified in this catalog.

Thank you for your accessing to ROHM product informations.

More detail product informations and catalogs are available, please contact your nearest sales office.

ROHM Customer Support System

THE AMERICAS / EUROPE / ASIA / JAPAN

www.rohm.com

Contact us : webmaster@rohm.co.jp