

Chip tantalum capacitors

TCT Series AS Case

●Features (AS)

- 1) Vital for all hybrid integrated circuits board application.
- 2) Wide capacitance range.
- 3) Screening by thermal shock.

●Dimensions (Unit : mm)

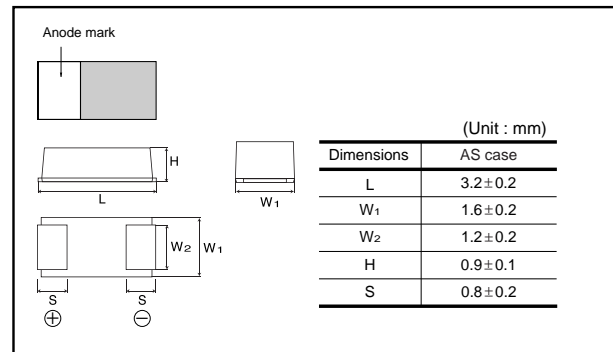

●Part No. Explanation

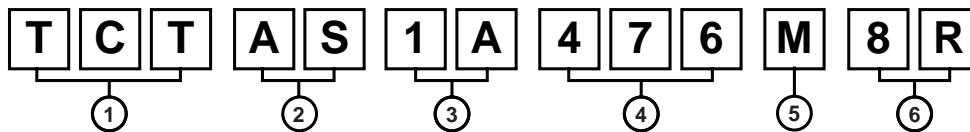

① Series name
TCT

② Case style
AS

③ Rated voltage

Rated voltage (V)	2.5	4	6.3	10	16	20
CODE	0E	0G	0J	1A	1C	1D

④ Nominal capacitance
Nominal capacitance in pF in 3 digits:
2 significant figures followed by the figure
representing the number of 0's.

⑤ Capacitance tolerance
M : ±20%

⑥ Taping
8 : Tape width
R : Positive electrode on the side opposite to sprocket hole

Tantalum capacitors

● Rated table

(μF)	Rated voltage (V)					
	2.5 0E	4 0G	6.3 0J	10 1A	16 1C	20 1D
10 (106)						AS
15 (156)					*AS	
22 (226)					AS	
33 (336)				*AS		
47 (476)			AS	*AS		
68 (686)			*AS			
100 (107)		AS				
150 (157)						
220 (227)	*AS					

Remark) Case size codes (AS) in the above show products line-up.
* Under development

● Marking

The indications listed below should be given on the surface of a capacitor.

- (1) Polarity : The polarity should be shown by □ bar. (on the anode side)
- (2) Rated DC voltage : Due to the small size of AS case, a voltage code is used as shown below.
- (3) Visual typical example (1) voltage code (2) capacitance code

Voltage Code	Rated DC Voltage (V)
e	2.5
g	4
j	6.3
A	10
C	16
D	20

Capacitance Code	Nominal Capacitance (μF)
a	10
e	15
j	22
n	33
s	47
w	68
ā	100
ē	150
ĵ	220

[AS case] note 1) $\frac{A}{(1)} \frac{s}{(2)}$



note 2) voltage code and capacitance code are variable with parts number

Tantalum capacitors

● Characteristics

Item		Performance	Test conditions (based on JIS C 5101-1 and JIS C 5101-3)															
Operating Temperature		-55°C to +125°C	Voltage reduction when temperature exceeds +85°C															
Maximum operating temperature with no voltage derating		+85°C																
Rated voltage (VDC)		2.5 4 6.3 10 16 20	at 85°C															
Category voltage (VDC)		1.6 2.5 4 6.3 10 13	at 125°C															
Surge voltage (VDC)		3.2 5.0 8 13 20 26	at 85°C															
DC Leakage current		Shall be satisfied the voltage on " Standard list "	As per 4.9 JIS C 5101-1 As per 4.5.1 JIS C 5101-3 Voltage : Rated voltage for 5min															
Capacitance tolerance		Shall be satisfied allowance range. ±20%	As per 4.7 JIS C 5101-1 As per 4.5.2 JIS C 5101-3 Measuring frequency : 120±12Hz Measuring voltage : 0.5Vrms +1.5 to 2V.DC Measuring circuit : DC Equivalent series circuit															
Tangent of loss angle (Df, tan δ)		Shall be satisfied the voltage on " Standard list "	As per 4.8 JIS C 5101-1 As per 4.5.3 JIS C 5101-3 Measuring frequency : 120±12Hz Measuring voltage : 0.5Vrms +1.5 to 2V.DC Measuring circuit : DC Equivalent series circuit															
Impedance		Shall be satisfied the voltage on " Standard list "	As per 4.10 JIS C 5101-1 As per 4.5.4 JIS C 5101-3 Measuring frequency : 100±10kHz Measuring voltage : 0.5Vrms or less Measuring circuit : DC Equivalent series circuit															
Resistance to Soldering heat	Appearance	There should be no significant abnormality. The indications should be clear.	As per 4.14 JIS C 5101-1 As per 4.6 JIS C 5101-3 Dip in the solder bath Solder temp : 260±5°C Duration : 5±0.5s Repetition : 1 After the specimens, leave it at room temperature for over 24h and then measure the sample.															
	L.C.	Less than 200% of initial limit																
	ΔC / C	Within ±20% of initial value																
	Df (tan δ)	Less than 200% of initial limit																
Temperature cycle	Appearance	There should be no significant abnormality. The indications should be clear.	As per 4.16 JIS C 5101-1 As per 4.10 JIS C 5101-3 Repetition : 5 cycles (1 cycle : steps 1 to 4) without discontinuation.															
	L.C.	Less than 200% of initial limit																
	ΔC / C	Within ±20% of initial value																
	Df (tan δ)	Less than 200% of initial limit																
			<table border="1"> <thead> <tr> <th></th> <th>Temp.</th> <th>Time</th> </tr> </thead> <tbody> <tr> <td>1</td> <td>-55±3°C</td> <td>30±3min.</td> </tr> <tr> <td>2</td> <td>Room temp.</td> <td>3min. or less</td> </tr> <tr> <td>3</td> <td>125±2°C</td> <td>30±3min.</td> </tr> <tr> <td>4</td> <td>Room temp.</td> <td>3min. or less</td> </tr> </tbody> </table>		Temp.	Time	1	-55±3°C	30±3min.	2	Room temp.	3min. or less	3	125±2°C	30±3min.	4	Room temp.	3min. or less
	Temp.	Time																
1	-55±3°C	30±3min.																
2	Room temp.	3min. or less																
3	125±2°C	30±3min.																
4	Room temp.	3min. or less																
Moisture resistance	Appearance	There should be no significant abnormality. The indications should be clear.	As per 4.22 JIS C 5101-1 As per 4.12 JIS C 5101-3 After leaving the sample under such atmospheric condition that the temperature and humidity are 60±2°C and 90 to 95% RH, respectively, for 500±12h leave it at room temperature for over 24h and then measure the sample.															
	L.C.	Less than 200% of initial limit																
	ΔC / C	Within ±20% of initial value																
	Df (tan δ)	Less than 200% of initial limit																

Tantalum capacitors

Item	Performance	Test conditions (based on JIS C 5101-1 and JIS C 5101-3)	
Temperature Stability	Temp.	-55°C	As per 4.29 JIS C 5101-1 As per 4.13 JIS C 5101-3
	$\Delta C / C$	Within 0/-15% of initial value	
	Df (tan δ)	Shall be satisfied the voltage on " Standard list "	
	L.C.	-	
	Temp.	+85°C	
	$\Delta C / C$	Within +15/0% of initial value	
	Df (tan δ)	Shall be satisfied the voltage on " Standard list "	
	L.C.	Less than 0.2CV	
	Temp.	+125°C	
	$\Delta C / C$	Within +20/0% of initial value	
	Df (tan δ)	Shall be satisfied the voltage on " Standard list "	
L.C.	Less than 0.25CV		
Surge voltage	Appearance	There should be no significant abnormality.	As per 4.26 JIS C 5101-1 As per 4.14 JIS C 5101-3 Apply the specified surge voltage every 5 ± 0.5 min. for 30 ± 5 s. each time in the atmospheric condition of $85 \pm 2^\circ\text{C}$. Repeat this procedure 1,000 times. After the specimens, leave it at room temperature for over 24h and then measure the sample.
	L.C.	Less than 200% of initial value	
	$\Delta C / C$	Within $\pm 20\%$ of initial value	
	Df (tan δ)	Less than 200% of initial limit	
Loading at High temperature	Appearance	There should be no significant abnormality.	As per 4.23 JIS C 5101-1 As per 4.15 JIS C 5101-3 After applying the rated voltage for $2000 + 72/0$ h without discontinuation via the serial resistance of 3Ω or less at a temperature of $85 \pm 2^\circ\text{C}$, leave the sample at room temperature / humidity for over 24h and measure the value.
	L.C.	Less than 200% of initial limit	
	$\Delta C / C$	Within $\pm 20\%$ of initial value	
	Df (tan δ)	Less than 200% of initial limit	
Terminal strength	Capacitance	The measured value should be stable.	As per 4.35 JIS C 5101-1 As per 4.9 JIS C 5101-3 A force is applied to the terminal until it bends to 1mm and by a prescribed tool maintain the condition for 5s. (See the figure below)
	Appearance	There should be no significant abnormality.	

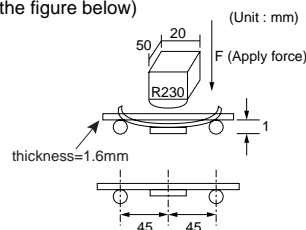

TCT Series AS Case

Tantalum capacitors

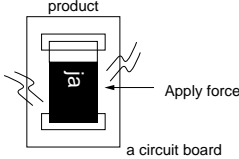
Item	Performance	Test conditions (JIS C 5101-1 and JIS C 5101-3)
Adhesiveness	The terminal should not come off.	As per 4.34 JIS C 5101-1 As per 4.8 JIS C 5101-3 Apply force of 5N in the two directions shown in the figure below for 10±1s after mounting the terminal on a circuit board. 
Dimensions	Refer to "External dimensions"	Measure using a caliper of JIS B 7507 Class 2 or higher grade.
Resistance to solvents	The indication should be clear	As per 4.32 JIS C 5101-1 As per 4.18 JIS C 5101-3 Dip in the isopropyl alcohol for 30±5s, at room temperature.
Solderability	3/4 or more surface area of the solder coated terminal dipped in the soldering bath should be covered with the new solder.	As per 4.15.2 JIS C 5101-1 As per 4.7 JIS C 5101-3 Dip speed=25±2.5mm / s Pre-treatment (accelerated aging): Leave the sample on the boiling distilled water for 1 h. Solder temp. : 245±5°C Duration : 3±0.5s Solder : M705 Flux : Rosin 25% IPA 75%
Vibration	Capacitance	Measure value should not fluctuate during the measurement.
	Appearance	There should be no significant abnormality.
		As per 4.17 JIS C 5101-1 Frequency : 10 to 55 to 10Hz/min. Amplitude : 1.5mm Time : 2h each in X and Y directions Mounting : The terminal is soldered on a print circuit board.

● Standard products list, TCT series

Part No.	Rated voltage 85°C (V)	Category voltage 125°C (V)	Surge voltage 85°C (V)	Cap. 120Hz (μF)	Tolerance (%)	Leakage current 25°C 1WV.5min (μA)	Tangent of loss angle 120Hz (%)			Impedance 100kHz (Ω)
							-55°C	25°C 85°C	125°C	
TCT AS 0G 107M	4	2.5	5.2	100	±20	4	35	20	25	3
TCT AS 0J 476M	6.3	4	8.0	47	±20	3	35	20	25	4
*TCT AS 0J 686M	6.3	4	8	68	±20	4.3	35	20	25	4
*TCT AS 1A 336M	10	6.3	13	33	±20	3.3	30	15	20	4
*TCT AS 1A 476M	10	6.3	13	47	±20	9.4	35	20	25	4
*TCT AS 1C 156M	16	10	20	15	±20	2.4	30	15	20	4
TCT AS 1C 226M	16	10	20	22	±20	3.6	35	20	25	4
TCT AS 1D 106M	20	13	26	10	±20	2.0	30	15	20	4

* : Under development

Tantalum capacitors

● Packaging specifications

Case code	A±0.1	B±0.1	t1±0.05	t2±0.1
AS	1.9	3.5	0.25	1.1

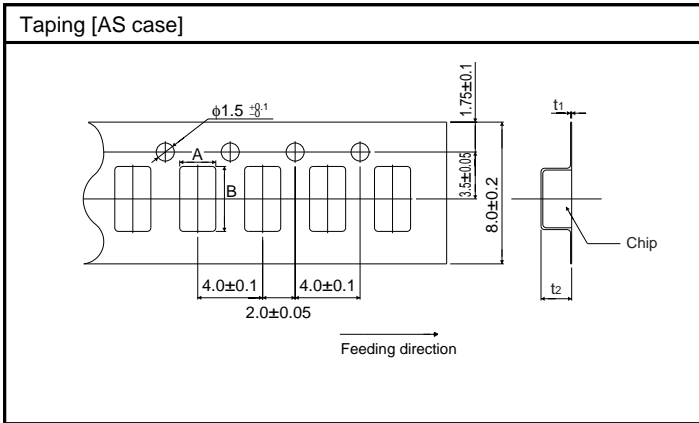

● Packaging style

Case code	Packaging	Packaging style		Symbol	Basic ordering units
AS case	Taping	plastic taping	$\phi 180$ mm Reel	R	3,000pcs

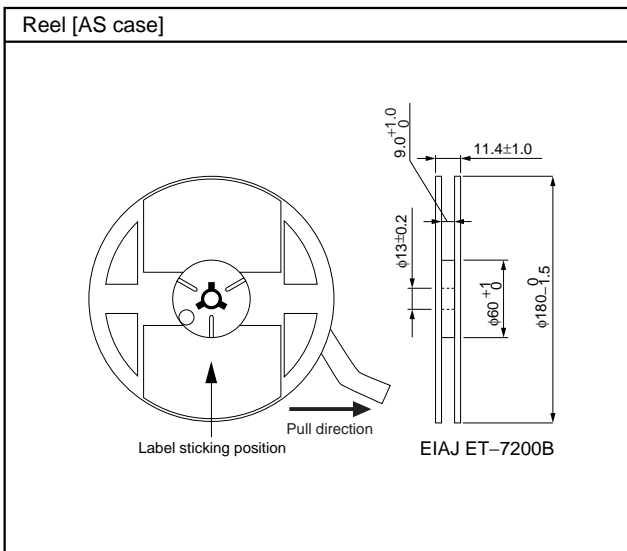

Tantalum capacitors

●Electrical characteristics and operation note

(1) Leakage current-to-voltage ratio

The leakage current increases exponentially to applied voltage. If the leakage current is problem, use it at low voltage, please.

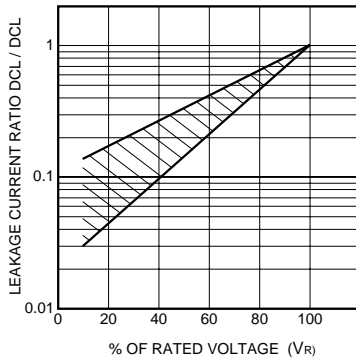

Fig.1

(2) Derating voltage as function of temperature

Please don't forget voltage derating in design.

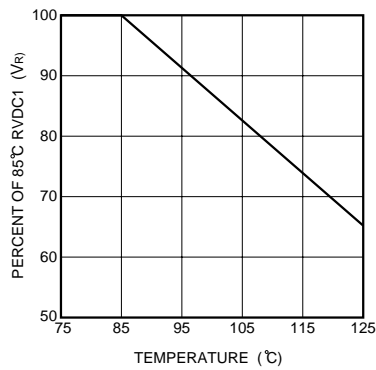

Fig.2

85 °C		125 °C	
Rated Voltage (V.DC)	Surge Voltage (V.DC)	Category Voltage (V.DC)	Surge Voltage (V.DC)
2.5	3.2	1.6	2.0
4	5	2.5	3.2
6.3	8	4	5
10	13	6.3	8
16	20	10	13
20	26	13	16

(3) Reliability

The malfunction rate of tantalum solid state electrolytic capacitors varies considerably depending on the conditions of usage (ambient temperature, applied voltage, circuit resistance).

Formula for calculating malfunction rate

$$\lambda_p = \lambda_b \times (\pi_E \times \pi_{SR} \times \pi_Q \times \pi_{CV})$$

- λ_p : Malfunction rate stemming from operation
- λ_b : Basic malfunction rate
- π_E : Environmental factors
- π_{SR} : Series resistance
- π_Q : Level of malfunction rate
- π_{CV} : Capacitance

For details on how to calculate the malfunction rate stemming from operation, see the tantalum solid state electrolytic capacitors column in MIL-HDBK-217.

Tantalum capacitors

Malfunction rate as function of operating temperature and rated voltage

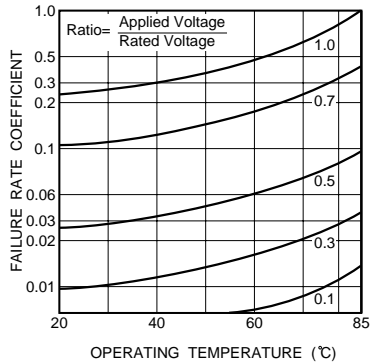

Fig.3

Malfunction rate as function of circuit resistance (Ω/V)

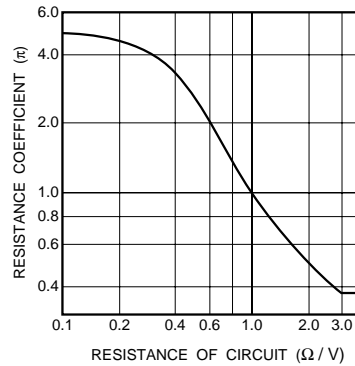

Fig.4

(4) Maximum power dissipation

Warming of the capacitor due to ripple voltage balances with warming caused by Joule heating and by radiated heat. Maximum allowable warming of the capacitor is to 5°C above ambient temperature. When warming exceeds 5°C, it can damage the dielectric and cause a short circuit.

Power dissipation (P) = $I^2 \cdot R$

Ripple current

P : As shown in table at right

R : Equivalent series resistance

Notes:

1. Please be aware that when case size is changed, maximum allowable power dissipation is reduced.
2. Maximum power dissipation varies depending on the package. Be sure to use a case which will keep warming within the limits shown in the table below.

Allowable power dissipation (W) and maximum temperature rising

Temp.	+25°C	+55°C	+85°C	+125°C
Case				
AS case (3216)	0.053	0.047	0.042	0.021
Max. Temp Rise [°C]	5	5	5	2

Tantalum capacitors

(5) Frequency characteristics

Please consider frequency characteristics in design. Below figure are example of impedance an ESR.

Impedance frequency characteristics

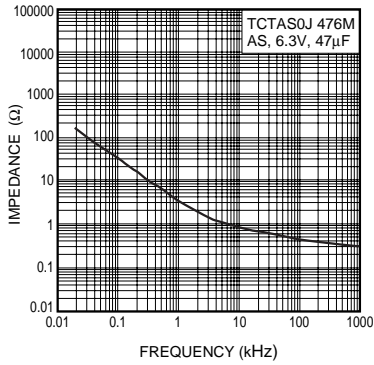

Fig.5

ESR frequency characteristics

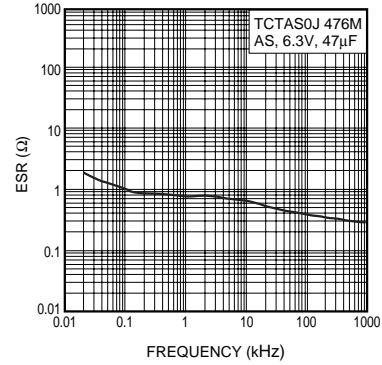

Fig.6

(6) Temperature characteristics

Please consider temperature characteristics in design. Below figures are example of TCTAL1A476.

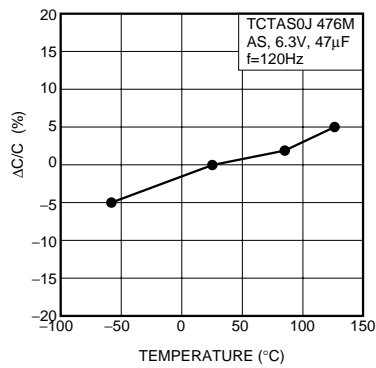

Fig.7

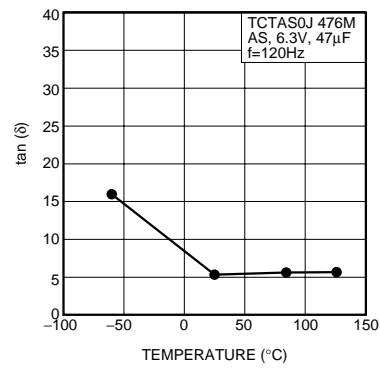

Fig.8

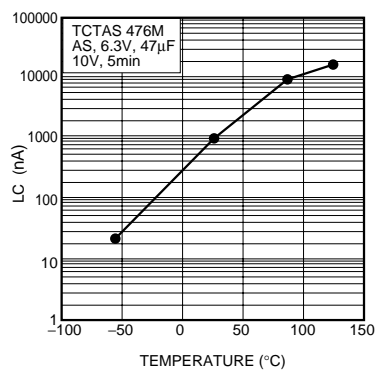

Fig.9

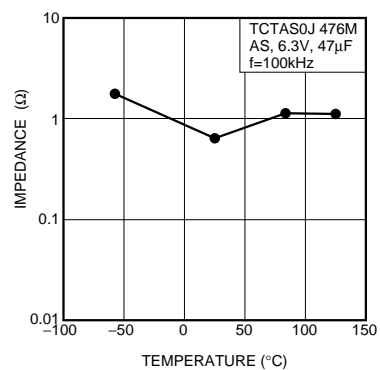

Fig.10

Notes

- No technical content pages of this document may be reproduced in any form or transmitted by any means without prior permission of ROHM CO.,LTD.
- The contents described herein are subject to change without notice. The specifications for the product described in this document are for reference only. Upon actual use, therefore, please request that specifications to be separately delivered.
- Application circuit diagrams and circuit constants contained herein are shown as examples of standard use and operation. Please pay careful attention to the peripheral conditions when designing circuits and deciding upon circuit constants in the set.
- Any data, including, but not limited to application circuit diagrams information, described herein are intended only as illustrations of such devices and not as the specifications for such devices. ROHM CO.,LTD. disclaims any warranty that any use of such devices shall be free from infringement of any third party's intellectual property rights or other proprietary rights, and further, assumes no liability of whatsoever nature in the event of any such infringement, or arising from or connected with or related to the use of such devices.
- Upon the sale of any such devices, other than for buyer's right to use such devices itself, resell or otherwise dispose of the same, no express or implied right or license to practice or commercially exploit any intellectual property rights or other proprietary rights owned or controlled by
- ROHM CO., LTD. is granted to any such buyer.
- Products listed in this document are no antiradiation design.

The products listed in this document are designed to be used with ordinary electronic equipment or devices (such as audio visual equipment, office-automation equipment, communications devices, electrical appliances and electronic toys).

Should you intend to use these products with equipment or devices which require an extremely high level of reliability and the malfunction of which would directly endanger human life (such as medical instruments, transportation equipment, aerospace machinery, nuclear-reactor controllers, fuel controllers and other safety devices), please be sure to consult with our sales representative in advance.

It is our top priority to supply products with the utmost quality and reliability. However, there is always a chance of failure due to unexpected factors. Therefore, please take into account the derating characteristics and allow for sufficient safety features, such as extra margin, anti-flammability, and fail-safe measures when designing in order to prevent possible accidents that may result in bodily harm or fire caused by component failure. ROHM cannot be held responsible for any damages arising from the use of the products under conditions out of the range of the specifications or due to non-compliance with the NOTES specified in this catalog.

Thank you for your accessing to ROHM product informations.

More detail product informations and catalogs are available, please contact your nearest sales office.

ROHM Customer Support System

THE AMERICAS / EUROPE / ASIA / JAPAN

www.rohm.com

Contact us : webmaster@rohm.co.jp