

# Chip tantalum capacitors

## TCO Series A Case

●Features (A)

- 1) Conductive polymer used for the cathode material.
- 2) Ultra-low ESR.  
(1/10 compared with the conventional type)
- 3) Screening by thermal shock.

●Dimensions (Unit : mm)

(Unit : mm)	
Dimensions	A case
L	3.2±0.2
W <sub>1</sub>	1.6±0.2
W <sub>2</sub>	1.2±0.2
H	1.6±0.2
S	0.8±0.3

●Part No. Explanation

Series name

**T C O**

Case style

**A 0 J**

Code	Rated voltage (V)
<b>0E</b>	2.5
<b>0G</b>	4
<b>0J</b>	6.3
<b>1A</b>	10

Nominal capacitance

**1 0 6 M 8 R**

Nominal capacitance in pF in 3 digits: 2 significant figures followed by the figure representing the number of 0's.

Code	Capacitance tolerance
<b>M</b>	± 20%

Code	Capacitance tolerance
<b>8</b>	Tape width

**R** : Positive electrode on the side opposite to sprocket hole

Tantalum capacitors

● **Rated Table. Marking**

TCO Series A Case

μF		Rated voltage (V.DC)			
		2.5 0E	4 0G	6.3 0J	10 1A
A	1.0				
E	1.5				
J	2.2				
N	3.3				A
S	4.7			A	A
W	6.8		A	A	A
a	10	A	A	A	A
e	15	A	A	A	
j	22	A	A	A	
n	33	A	A		
s	47	A	<i>New</i> A		
w	68	* A			

\* Under development  
*New* indicates new product

● **Marking**

The indications listed below should be given on the surface of a capacitor.

- (1) Polarity : The polarity should be shown by □ bar. (on the anode side)
- (2) Rated DC voltage : Due to the small size of A case, a voltage code is used as shown below.
- (3) Visual typical example (1) voltage code (2) capacitance code

Voltage Code	Rated DC Voltage (V)
e	2.5
g	4
j	6.3
A	10

Capacitance Code	Nominal Capacitance (μF)
A	1.0
E	1.5
J	2.2
N	3.3
S	4.7
W	6.8
a	10
e	15
j	22
n	33
s	47

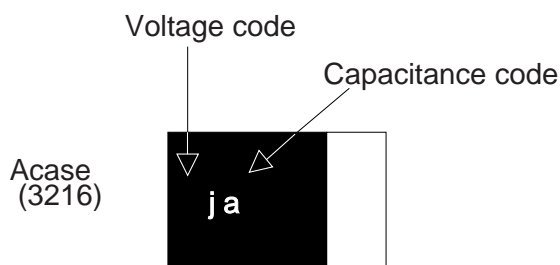

## Tantalum capacitors

## ●Characteristics

Item	Performance				Test conditions (based on JIS C 5101-1 and JIS C 5101-3)
Operating Temperature	-55°C to +105°C				Voltage reduction when temperature exceeds +85°C
Maximum operating temperature with no voltage derating	+85°C				
Rated voltage (VDC)	2.5	4	6.3	10	at 85°C
Category voltage (VDC)	2	3.2	5	8	at 105°C
Surge voltage (VDC)	3.2	5.2	8	13	at 85°C
DC Leakage current	3μA or 0.1CV whichever is greater Shown in " Standard list "				Rated voltage for 5min
Capacitance tolerance	±20% Shall be satisfied allowance range.				Measuring frequency : 120±12Hz Measuring voltage : 0.5Vrms +1.5 to 2V.DC Measuring circuit : DC Equivalent series circuit
Tangent of loss angle (Df, tan δ)	Shall be satisfied the voltage on " Standard list "				Measuring frequency : 120±12Hz Measuring voltage : 0.5Vrms +1.5 to 2V.DC Measuring circuit : DC Equivalent series circuit
ESR	Shall be satisfied the voltage on " Standard list "				Measuring frequency : 100±10kHz Measuring voltage : 0.5Vrms or less
Resistance to Soldering heat	Appearance	There should be nonsignificant abnormality. The indications should be clear.			Dip in the solder bath Solder temp : 240±5°C Duration : 10±0.5s Repetition : 1 After the specimens, leave it at room temperature for over 24h and then measure the sample.
	L.C.	Less than 150% of initial limit			
	ΔC / C	Within ±20% of initial value			
	tan δ	Less than 150% of initial limit			

## Tantalum capacitors

Item		Performance	Test conditions (based on JIS C 5101-1 and JIS C 5101-3)															
Temperature cycle	Appearance	There should be no significant abnormality.	Repetition : 5 cycles (1 cycle : steps 1 to 4) without discontinuation. <table border="1" data-bbox="948 459 1235 600"> <thead> <tr> <th></th> <th>Temp.</th> <th>Time</th> </tr> </thead> <tbody> <tr> <td>1</td> <td>-55±3°C</td> <td>30±3min</td> </tr> <tr> <td>2</td> <td>Room temp.</td> <td>3min.or less</td> </tr> <tr> <td>3</td> <td>105±2°C</td> <td>30±3min</td> </tr> <tr> <td>4</td> <td>Room temp.</td> <td>3min.or less</td> </tr> </tbody> </table> After the specimens, leave it at room temperature for over 24h and then measure the sample.		Temp.	Time	1	-55±3°C	30±3min	2	Room temp.	3min.or less	3	105±2°C	30±3min	4	Room temp.	3min.or less
		Temp.		Time														
	1	-55±3°C		30±3min														
	2	Room temp.		3min.or less														
3	105±2°C	30±3min																
4	Room temp.	3min.or less																
L.C	Less than 500% of initial limit																	
ΔC / C	Within±20% of intial value																	
Df (tan δ)	Less than 150% of initial limit																	
Moisture resistance	Appearance	There should be no significant abnormality. The indications should be	After leaving the sample under such atmospheric condition that the temperature and humidity are 40±2°C and 90 to 95% RH, respectively, for 500±24h leave it at room temperature for over 24h and then measure the sample.															
	L.C	Less than 150% of initial limit																
	ΔC / C	+30% / -20%																
	Df (tan δ)	Less than 150% of initial limit																
Temperature Stability	Temp.	-55°C																
	ΔC / C	Within 0/-20% of initial value																
	Df (tan δ)	Shall be satisfied the voltage on " Standard list "																
	L.C	-																
	Temp.	+105°C																
	ΔC / C	Within +50/0% of initial value																
	Df (tan δ)	Shall be satisfied the voltage on " Standard list "																
L.C	Less than 1CV																	
Surge voltage	Appearance	There should be no significant abnormality.	Apply the specified serge voltage every 5±0.5 min. for 30±5 s. each time in the atmospheric condition of 85±2°C. Repeat this rocedure 1,000 times. After the specimens, leave it at room temperature for over 24h and then measure the sample.															
	L.C	Less than initial limit																
	ΔC / C	Within±20% of initial value																
	Df (tan δ)	Less than initial limit																

## Tantalum capacitors

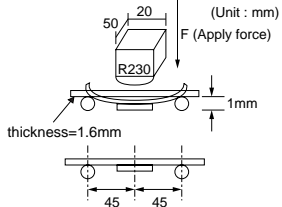
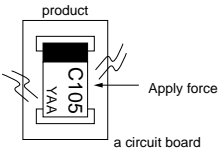
Item		Performance	Test conditions (based on JIS C 5101-1 and JIS C 5101-3)
Loading at High temperature	Appearance	There should be nonsignificant abnormality.	After applying the rated voltage for $1000^{+72}$ h without discontinuation via the serial resistance of $3\Omega$ or less at a temperature of $85 \pm 2^\circ\text{C}$ , leave the sample at room temperature / humidity for over 24h and measure the value.
	L.C	Less than 200% of initial limit	
	$\Delta C / C$	Within $\pm 20\%$ of initial value	
	Df (tan $\delta$ )	150% of initial limit less than	
Terminal strength	Capacitance	The measured value should be stable.	A force is applied to the terminal until it bends to 1mm and by a prescribed tool maintain the condition for 5s.(See the figure below) 
	Appearance	There should nonsignificant abnormality.	
Adhesiveness		The terminal should not come off.	Apply force of 5N in the two directions shown in the figure below for $10 \pm 1$ s after mounting the terminal on a circuit board. 
Dimensions		Refer to "External dimensions"	Measure using a caliper of JISB 7507 Class 2 or higher grade.
Resistance to solvents		The indication should be clear	Dip in the isopropyl alcohol for $30 \pm 5$ s, at room temperature.
Solderability		3/4 or more surface area of the solder coated terminal dipped in the soldering bath should be covered with the new solder.	Dip speed= $25 \pm 2.5$ mm / s Pre-treatment(accelerated aging): Leave the sample on the boiling distilled water for 1 h. Solder temp.: $245 \pm 5^\circ\text{C}$ Duration : $3 \pm 0.5$ s Solder : M705 Flux : Rosin25% IPA75%
Vibration	Capacitance	Measure value should not fluctuate during the measurement.	Frequency : 10 to 55 to 10Hz/min. Amplitude : 1.5mm Time : 2h each in X and Y directions Mounting : The terminal is soldered on a print circuit board.
	Appearance	There should no significant abnormality.	

# TCO series A Case

## Tantalum capacitors

### ●Standard list, TCO series

< A case : 3216 size >

Part No.	Rated Voltage 85°C (V)	Category Voltage 105°C (V)	Surge Voltage 85°C (V)	Cap. 120Hz (μF)	Tolerance (%)	Leakage Current 25°C 1WV 5min (μA)	Df 120Hz (%)			ESR 100kHz (mΩ)
							-55°C	25°C 85°C	105°C	
TCO A 0E 106 □	2.5	2.0	3.2	10	±20	3.0	6	6	9	500
TCO A 0E 156 □				15		3.8				
TCO A 0E 226 □				22		5.5				
TCO A 0E 336 □				33		8.3				
TCO A 0E 476 □				47		11.7				
TCO A 0G 685 □	4	3.2	5.2	6.8	±20	3.0	6	6	9	800
TCO A 0G 106 □				10		4.0				500
TCO A 0G 156 □				15		6.0				
TCO A 0G 226 □				22		8.8				
TCO A 0G 336 □				33		13.2				
TCO A 0G 476 □	47	18.8	200							
TCO A 0J 475 □	6.3	5	8	4.7	±20	3.0	6	6	9	500
TCO A 0J 685 □				6.8		4.3				
TCO A 0J 106 □				10		6.3				
TCO A 0J 156 □				15		9.5				
TCO A 0J 226 □				22		13.9				
TCO A 1A 335 □	10	8	13	3.3	±20	3.3	6	6	9	800
TCO A 1A 475 □				4.7		4.7				
TCO A 1A 685 □				6.8		6.8				
TCO A 1A 106 □				10		10.0				

□=Tolerance(M : ±20%)

### ●Packaging specifications

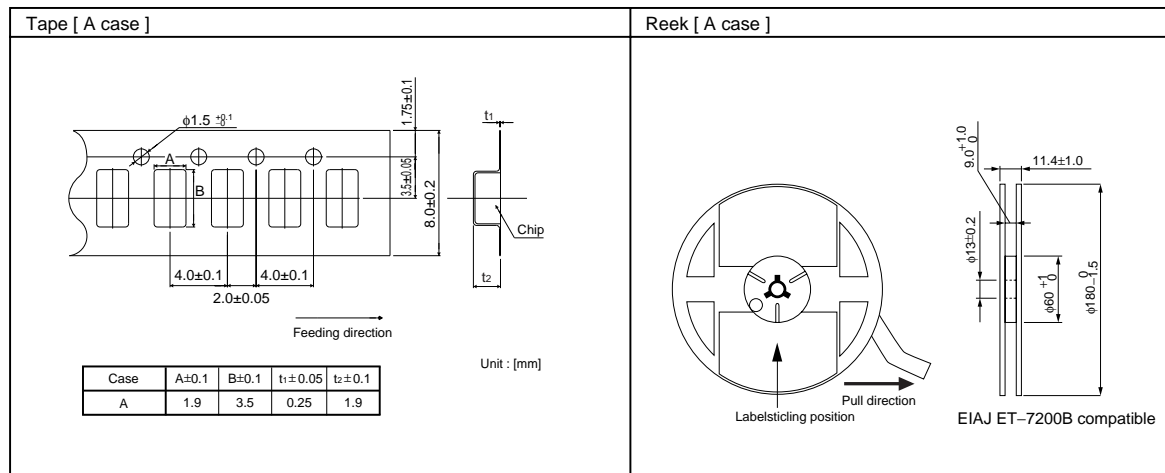

### ●Packaging style

Case code	package	Packaging style		Symbol	Basic ordering units
A	Taping	plastic taping	φ180mmReel	R	2,000pcs

Tantalum capacitors

● Damp proof package

- ① One reel is packed in aluminum bag.  
The size of aluminum bag is 240(g) x 250(b)mm.  
The size up to 230(c)mm is to zipper.
- ② A desiccant is packed with a reel.
- ③ The aluminum bag is heat-sealed.
- ④ The label of the same as the label on the reel is placed on the aluminum bag.

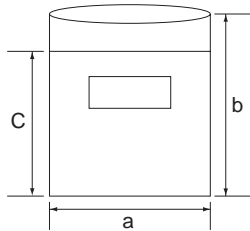

● Electrical characteristics and operation notes

(1) Leakage current-to-voltage ratio

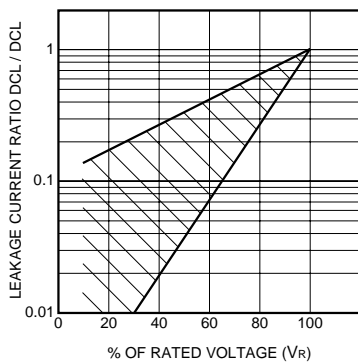

Fig.1

(2) Derating voltage as function of temperature

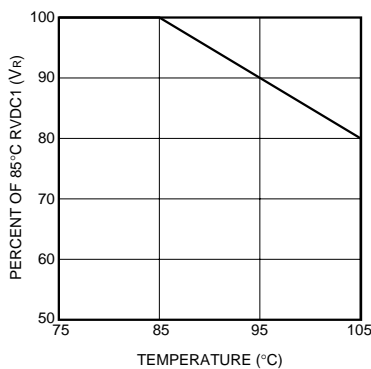

Fig.2

85°C		105°C
Rated Voltage (V.DC)	Surge Voltage (V.DC)	Category Voltage (V.DC)
2.5	3.2	2
4	5.2	3.2
6.3	8	5
10	13	8

Tantalum capacitors

(3) Reliability

The malfunction rate of tantalum solid state electrolytic capacitors varies considerably depending on the conditions of usage (ambient temperature, applied voltage, circuit resistance).

Formula for calculating malfunction rate

$$\lambda_p = \lambda_b \times (\pi_E \times \pi_{SR} \times \pi_Q \times \pi_{CV})$$

- $\lambda_p$  : Malfunction rate stemming from operation
- $\lambda_b$  : Basic malfunction rate
- $\pi_E$  : Environmental factors
- $\pi_{SR}$  : Series resistance
- $\pi_Q$  : Level of malfunction rate
- $\pi_{CV}$  : Capacitance

For details on how to calculate the malfunction rate stemming from operation, see the tantalum solid state electrolytic capacitors column in MIL-HDBK-217.

(4) Impedance frequency characteristics

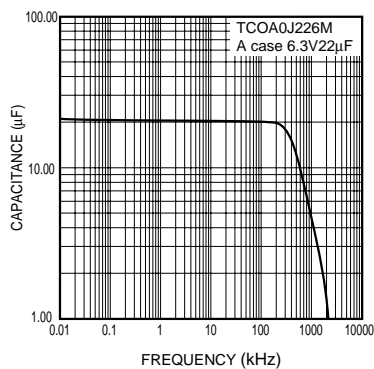

Fig.3

(5) ESR frequency characteristics

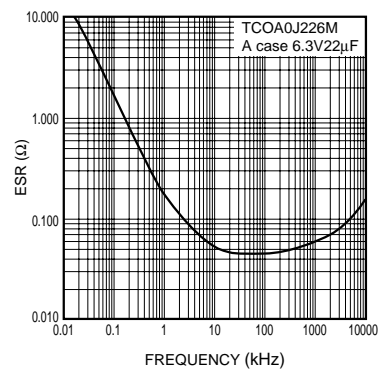

Fig.4

(6) Capacitance temperature characteristics 120Hz

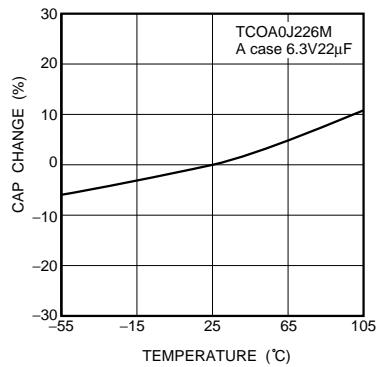

Fig.5

(7) ESR temperature characteristics 100kHz

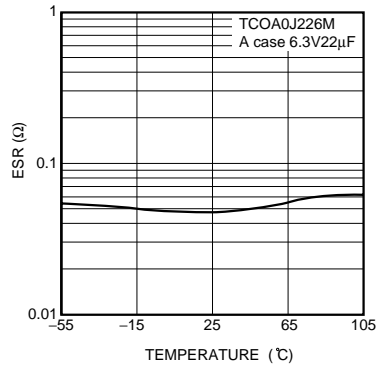

Fig.6

### Notes

- No technical content pages of this document may be reproduced in any form or transmitted by any means without prior permission of ROHM CO.,LTD.
- The contents described herein are subject to change without notice. The specifications for the product described in this document are for reference only. Upon actual use, therefore, please request that specifications to be separately delivered.
- Application circuit diagrams and circuit constants contained herein are shown as examples of standard use and operation. Please pay careful attention to the peripheral conditions when designing circuits and deciding upon circuit constants in the set.
- Any data, including, but not limited to application circuit diagrams information, described herein are intended only as illustrations of such devices and not as the specifications for such devices. ROHM CO.,LTD. disclaims any warranty that any use of such devices shall be free from infringement of any third party's intellectual property rights or other proprietary rights, and further, assumes no liability of whatsoever nature in the event of any such infringement, or arising from or connected with or related to the use of such devices.
- Upon the sale of any such devices, other than for buyer's right to use such devices itself, resell or otherwise dispose of the same, no express or implied right or license to practice or commercially exploit any intellectual property rights or other proprietary rights owned or controlled by
- ROHM CO., LTD. is granted to any such buyer.
- Products listed in this document are no antiradiation design.

The products listed in this document are designed to be used with ordinary electronic equipment or devices (such as audio visual equipment, office-automation equipment, communications devices, electrical appliances and electronic toys).

Should you intend to use these products with equipment or devices which require an extremely high level of reliability and the malfunction of which would directly endanger human life (such as medical instruments, transportation equipment, aerospace machinery, nuclear-reactor controllers, fuel controllers and other safety devices), please be sure to consult with our sales representative in advance.

It is our top priority to supply products with the utmost quality and reliability. However, there is always a chance of failure due to unexpected factors. Therefore, please take into account the derating characteristics and allow for sufficient safety features, such as extra margin, anti-flammability, and fail-safe measures when designing in order to prevent possible accidents that may result in bodily harm or fire caused by component failure. ROHM cannot be held responsible for any damages arising from the use of the products under conditions out of the range of the specifications or due to non-compliance with the NOTES specified in this catalog.

Thank you for your accessing to ROHM product informations.

More detail product informations and catalogs are available, please contact your nearest sales office.

**ROHM** Customer Support System

THE AMERICAS / EUROPE / ASIA / JAPAN

[www.rohm.com](http://www.rohm.com)

Contact us : [webmaster@rohm.co.jp](mailto:webmaster@rohm.co.jp)