

2012

Product Catalog

**ROHM**  
SEMICONDUCTOR

Passive Components

# Tantalum Capacitors



ROHM Co.,Ltd.



## Table of Contents

---

New Bottom Electrode Extra Large Capacitance Type .....	3
TCS Series:	
Bottom Electrode Large Capacitance Type .....	5
TCT Series:	
Fail-Safe Open Structure Type .....	7
TCFG Series:	
Standard Type .....	9
TC Series:	
Recommended Soldering Conditions .....	11
Part Number Explanation .....	12
Taping Specifications .....	12
Usage Precautions .....	13

# New Bottom Electrode Type (Extra Large Capacitance)

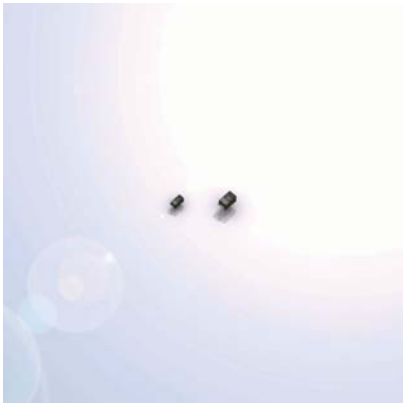

## TCS Series

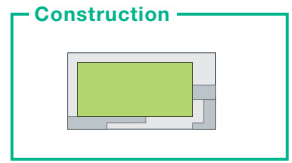

### Summary

The TCS series employs a high efficiency package design for greater compactness and a lower profile with extra large capacitance.

### Features

- Thin, compact
- Extra large capacitance
- Low ESR

### Applications

Mobile phones, digital cameras, digital camcorders, portable music players, and other thin, compact electronic devices

## New package construction features smaller, thinner form factor with larger capacitance

The unique package construction allows for a larger tantalum element than conventional bottom electrode types (TCT Series), resulting in approximately triple the capacitance.



### Lineup

#### M Case (1608-09 [0603])

Capacitance (µF)	Rated voltage(V, DC)			
	4	6.3	10	16
10 (106)				M
15 (156)			☆M	
22 (226)			M	
33 (336)		☆M		
47 (476)		M		
68 (686)	☆M			
100 (107)	M			
150 (157)				
220 (227)				
330 (337)				

☆Under development

#### P Case (2012-12 [0805])

Capacitance (µF)	Rated voltage(V, DC)						
	2.5	4	6.3	10	16	20	25
10 (106)						P	☆P
15 (156)							
22 (226)					☆P		
33 (336)				☆P	☆P		
47 (476)				P			
68 (686)							
100 (107)			P				
150 (157)			☆P				
220 (227)		P					
330 (337)	☆P						

☆Under development

## Quick Reference

TCS Series M Case (1608-09 [0603])

Rated Voltage (V)	Capacitance ( $\mu\text{F}$ )	$\tan\delta$ at 120Hz(25°C) (%)	Leakage current (25°C, 5min) ( $\mu\text{A}$ )	ESR (at 100kHz) ( $\Omega$ )	Part No.
4	68	40	27.2	4.0	TCSM0G686□
	100	40	80	4.0	TCSM0G107□
6.3	33	30	20.8	4.0	TCSM0J336□
	47	40	29.7	4.0	TCSM0J476□
10	15	20	7.5	6.0	TCSM1A156□
	22	30	11.0	5.0	TCSM1A226□
16	10	20	8.0	6.0	TCSM1C106□

□=Capacitance tolerance (M:±20%)

TCS Series P Case (2012-12 [0805])

Rated Voltage (V)	Capacitance ( $\mu\text{F}$ )	$\tan\delta$ at 120Hz(25°C) (%)	Leakage current (25°C, 5min) ( $\mu\text{A}$ )	ESR (at 100kHz) ( $\Omega$ )	Part No.
2.5	330	40	83	3.0	TCSP0E337□
4	220	40	88	3.0	TCSP0G227□
6.3	100	40	63	3.0	TCSP0J107□
	150	40	95	3.0	TCSP0J157□
10	33	30	17	4.0	TCSP1A336□
	47	30	24	4.0	TCSP1A476□
16	22	30	18	4.0	TCSP1C226□
	33	30	27	4.0	TCSP1C336□
20	10	20	10	6.0	TCSP1D106□
25	10	20	13	6.0	TCSP1E106□

□=Capacitance tolerance (M:±20%)

## Dimensions

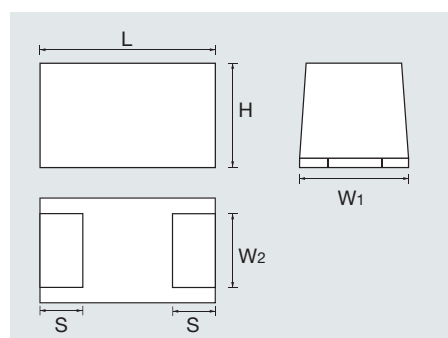

Case (mm [inch])	L	W <sub>1</sub>	W <sub>2</sub>	H	S
M (1608-09 [1603])	1.6 <sup>+0.2</sup> <sub>-0</sub>	0.85±0.1	0.55±0.1	0.8 <sup>+0.2</sup> <sub>-0</sub>	0.5±0.1
P (2012-12 [0805])	2.0±0.2	1.25±0.2	0.85±0.2	1.2 Max.	0.5±0.1

(Unit : mm)



Quick Reference

TCT Series: U Case (1005-05 [0402] Size)

Rated voltage (V)	Capacitance (μF)	tanδ at 120Hz(25°C) (%)	Leakage current (25°C, 5min) (μA)	Impedance (at 100kHz) (Ω)	Part No.
4	4.7	20	1.9	20	TCTU0G475□
6.3	1.0	20	0.7	20	TCTU0J105□
	2.2	20	1.4	20	TCTU0J225□

□=Capacitance tolerance (M:±20%)

TC Series: M Case (1608-09 [0603] Size)

Rated voltage (V)	Capacitance (μF)	tanδ at 120Hz(25°C) (%)	Leakage current (25°C, 5min) (μA)	Impedance (at 100kHz) (Ω)	Part No.
4	10	20	0.5	9.0	TCM0G106□
	22	20	0.9	9.0	TCM0G226□
	33	30	13.0	9.0	TCM0G336□
6.3	4.7	20	0.5	9.0	TCM0J475□
	10	20	0.6	9.0	TCM0J106□
	22	30	13.0	9.0	TCM0J226□
10	1.0	10	0.5	15.0	TCM1A105□
	2.2	20	0.5	13.5	TCM1A225□
	4.7	20	0.5	9.0	TCM1A475□
	10	20	10.0	9.0	TCM1A106□
16	1.0	10	0.5	15.0	TCM1C105□
	2.2	20	0.5	13.5	TCM1C225□

□=Capacitance tolerance (M:±20%)

TCT Series: PL Case (Low Profile 2012-10 [0805] Size)

Rated voltage (V)	Capacitance (μF)	tanδ at 120Hz(25°C) (%)	Leakage current (25°C, 5min) (μA)	Impedance (at 100kHz) (Ω)	Part No.
4	47	20	9.4	4.0	TCTPLOG476□
	68	30	13.6	4.0	TCTPLOG686□
	100	30	20.0	4.0	TCTPLOG107□
6.3	33	20	10.4	4.0	TCTPLOJ336□
	47	30	14.8	4.0	TCTPLOJ476□
10	22	20	11.0	5.0	TCTPL1A226□
	33	30	16.5	4.0	TCTPL1A336□
16	10	20	3.2	6.0	TCTPL1C106□
	3.3	20	1.4	8.0	TCTPL1D335□
	4.7	20	1.9	6.0	TCTPL1D475□
20	6.8	20	2.8	6.0	TCTPL1D685□
	1.5	20	0.8	8.0	TCTPL1E155□
25	2.2	20	1.1	8.0	TCTPL1E225□
	3.3	20	0.7	8.0	TCTPL1V105□

□=Capacitance tolerance (M:±20%)

TCT Series: P Case (2012-10 [0805] Size)

Rated voltage (V)	Capacitance (μF)	tanδ at 120Hz(25°C) (%)	Leakage current (25°C, 5min) (μA)	Impedance (at 100kHz) (Ω)	Part No.
4	33	20	1.3	4.0	TCTP0G336□
	47	20	1.9	4.0	TCTP0G476□
	68	30	-	4.0	TCTP0G686□
	100	30	-	4.0	TCTP0G107□
6.3	22	20	1.4	4.0	TCTP0J226□
	33	20	2.1	5.0	TCTP0J336□
	47	30	-	4.0	TCTP0J476□
	68	30	-	4.0	TCTP0J686□
10	15	20	1.5	4.0	TCTP1A156□
	22	20	2.2	6.0	TCTP1A226□
	33	30	16.5	5.0	TCTP1A336□
	47	30	-	4.0	TCTP1A476□
16	10	20	1.6	4.0	TCTP1C106□
	4.7	20	1.0	6.0	TCTP1D475□
20	6.8	20	1.4	6.0	TCTP1D685□
	2.2	20	0.6	8.0	TCTP1E225□
25	3.3	20	0.9	8.0	TCTP1E335□
	1.0	20	0.5	8.0	TCTP1V105□
35	1.5	20	0.6	8.0	TCTP1V155□

□=Capacitance tolerance (M:±20%)

TCT Series: AS Case (Ultra-Low Profile 3216-10 [1206] Size)

Rated voltage (V)	Capacitance (μF)	tanδ at 120Hz(25°C) (%)	Leakage current (25°C, 5min) (μA)	Impedance (at 100kHz) (Ω)	Part No.
4	100	20	20.0	3.0	TCTAS0G107□
	220	30	88.0	2.5	TCTAS0G227□
6.3	47	20	6.0	4.0	TCTAS0J476□
	68	20	21.5	4.0	TCTAS0J686□
	100	18	31.5	3.0	TCTAS0J107□
10	33	15	6.6	4.0	TCTAS1A336□
	47	20	9.4	4.0	TCTAS1A476□
16	15	15	4.8	4.0	TCTAS1C156□
	22	20	7.1	4.0	TCTAS1C226□
20	10	15	4.0	4.0	TCTAS1D106□
25	4.7	15	2.4	8.0	TCTAS1E475□
35	1.0	15	0.7	8.0	TCTAS1V105□

□=Capacitance tolerance (M:±20%)

TCT Series: AL Case (Low Profile 3216-12 [1206] Size)

Rated voltage (V)	Capacitance (μF)	tanδ at 120Hz(25°C) (%)	Leakage current (25°C, 5min) (μA)	Impedance (at 100kHz) (Ω)	Part No.
2.5	220	20	5.5	2.5	TCTAL0E227□
	330	30	16.5	2.5	TCTAL0E337□
4	100	20	4.0	3.0	TCTAL0G107□
	150	20	6.0	2.7	TCTAL0G157□
	220	20	20.0	2.5	TCTAL0G227□
6.3	68	20	4.3	4.0	TCTAL0J686□
	100	18	6.3	3.0	TCTAL0J107□
	150	30	94.5	2.7	TCTAL0J157□
10	33	15	3.3	4.0	TCTAL1A336□
	47	20	4.7	4.0	TCTAL1A476□
16	15	15	2.4	4.0	TCTAL1C156□
	22	20	3.6	4.0	TCTAL1C226□
	33	20	5.3	4.0	TCTAL1C336□
20	10	15	2.0	8.0	TCTAL1D106□
	15	15	3.0	4.0	TCTAL1D156□
25	4.7	15	1.2	8.0	TCTAL1E475□
	6.8	15	1.7	8.0	TCTAL1E685□
35	1.0	15	0.5	8.0	TCTAL1V105□
	1.5	15	0.5	8.0	TCTAL1V155□
	2.2	15	0.8	8.0	TCTAL1V225□
	3.3	15	1.2	8.0	TCTAL1V335□

□=Capacitance tolerance (M:±20%)

Dimensions

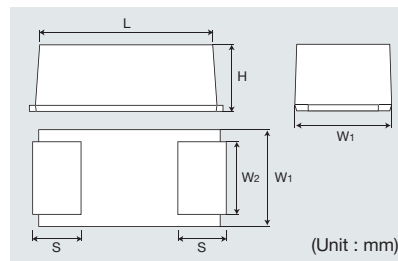

Case (mm [inch])	L	W1	W2	H	S
U (1005-06 [0402])	1.0 <sup>+0.2</sup> <sub>-0</sub>	0.5 <sup>+0.2</sup> <sub>-0</sub>	0.35±0.1	0.6 Max.	0.35±0.1
M (1608-09 [0603])	1.6±0.1	0.85±0.1	0.55±0.1	0.8±0.1	0.5±0.1
PL (Low Profile 2012-10 [0805])	2.0±0.2	1.25±0.2	0.85±0.2	0.9±0.1	0.5±0.2
P (2012-12 [0805])	2.0±0.2	1.25±0.2	0.85±0.2	1.2 Max.	0.5±0.2
AS (Ultra-Low Profile 3216-10 [1206])	3.2±0.2	1.6±0.2	1.2±0.2	0.9±0.1	0.8±0.2
AL (Low Profile 3216-12 [1206])	3.2±0.2	1.6±0.2	1.2±0.2	1.1±0.1	0.8±0.2
CL (Low Profile 6032-15 [2412])	6.0±0.2	3.2±0.2	2.2±0.2	1.4±0.1	1.3±0.2

(Unit : mm)

# Fail-Safe Open Structure Type



## TCFG Series

### Summary

High-reliability series with built-in (open) mechanism that shuts OFF the current during overheating.

### Features

- High reliability

### Construction

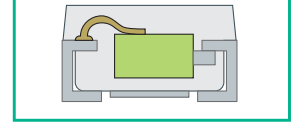

### Applications

PC, PC peripherals, digital cameras, digital camcorders, automotive ITS-related devices, electronic office equipment, and more.

## Open mechanism built in for greater reliability

The open configuration stops current flow once the unit overheats, preventing damage to other parts of the circuit, contributing to worry-free design.

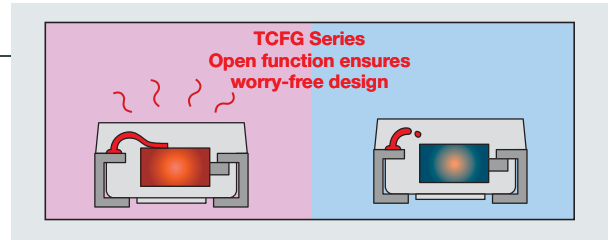

### Lineup

P Case (2012-12 [0805] Size)

Capacitance (μF)	Rated voltage(V, DC)					
	4	6.3	10	16	20	25
1.0 (105)			P	P	P	P
1.5 (155)		P	P	P		
2.2 (225)	P	P	P	P		
3.3 (335)	P	P	P	P		
4.7 (475)	P	P	P			
6.8 (685)	P	P	P			
10 (106)	P	P	P			
15 (156)	P	P				
22 (226)	P					
33 (336)						
47 (476)						
68 (686)						
100 (107)						
150 (157)						
220 (227)						
330 (337)						

A Case (3216-18 [1206] Size)

Capacitance (μF)	Rated voltage(V, DC)					
	4	6.3	10	16	20	25
1.0 (105)				A	A	A
1.5 (155)			A	A	A	A
2.2 (225)			A	A	A	A
3.3 (335)		A	A	A	A	A
4.7 (475)	A	A	A	A	A	A
6.8 (685)	A	A	A	A	A	A
10 (106)	A	A	A	A		
15 (156)	A	A	A			
22 (226)	A	A	A			
33 (336)	A	A				
47 (476)	A	A				
68 (686)	A					
100 (107)						
150 (157)						
220 (227)						
330 (337)						

B Case (3528-21 [1411] Size)

Capacitance (μF)	Rated voltage(V, DC)						
	2.5	4	6.3	10	16	20	25
1.0 (105)							
1.5 (155)							
2.2 (225)							
3.3 (335)					B	☆B	B
4.7 (475)				B	B	B	B
6.8 (685)				B	B	☆B	
10 (106)			B	B	B	B	
15 (156)		B	B	B	B		
22 (226)		B	B	B	B		
33 (336)		B	B	B	B		
47 (476)		B	B	B			
68 (686)		B	B	B			
100 (107)		B	B	B			
150 (157)		B	B	B			
220 (227)	B	B	B				
330 (337)	☆B	☆B					

☆Under development

C Case (6032-27 [2412] Size)

Capacitance (μF)	Rated voltage(V, DC)					
	4	6.3	10	16	20	25
15 (156)						C
22 (226)						
33 (336)						
47 (476)				C		
68 (686)						
100 (107)			C			
150 (157)		C				
220 (227)	☆C					
330 (337)						

☆Under development

D Case (7343-30 [2917] Size)

Capacitance (μF)	Rated voltage(V, DC)						
	4	6.3	10	16	20	25	35
15 (156)							
22 (226)							D
33 (336)							
47 (476)						D	
68 (686)					☆D		
100 (107)				D			
150 (157)			D				
220 (227)		D					
330 (337)	☆D						

☆Under development

Quick Reference

TCFG Series: P Case (2012-12 [0805] Size)

Rated voltage (V)	Capacitance (μF)	tanδ at 120Hz(25°C) (%)	Leakage current (25°C, 5min) (A)	Impedance (at 100kHz) (Ω)	Part No.
4	2.2	10	0.5	17.5	TCFGP0G225□
	3.3	20	0.5	17.5	TCFGP0G335□
	4.7	20	0.5	14.4	TCFGP0G475□
	6.8	20	0.5	11.8	TCFGP0G685□
	10	20	0.5	9.3	TCFGP0G106□
	15	20	0.6	8.3	TCFGP0G156□
22	20	0.9	7.7	TCFGP0G226□	
6.3	1.5	10	0.5	17.5	TCFGP0J155□
	2.2	20	0.5	17.5	TCFGP0J225□
	3.3	20	0.5	14.4	TCFGP0J335□
	4.7	20	0.5	11.8	TCFGP0J475□
	6.8	20	0.5	9.3	TCFGP0J685□
	10	20	0.6	8.3	TCFGP0J106□
15	20	0.9	7.7	TCFGP0J156□	
10	1.0	10	0.5	17.5	TCFGP1A105□
	1.5	20	0.5	16.1	TCFGP1A155□
	2.2	20	0.5	14.4	TCFGP1A225□
	3.3	20	0.5	11.8	TCFGP1A335□
	4.7	20	0.5	9.3	TCFGP1A475□
	6.8	20	0.7	8.3	TCFGP1A685□
10	20	1.0	7.7	TCFGP1A106□	
16	1.0	10	0.5	16.1	TCFGP1C105□
	1.5	20	0.5	14.4	TCFGP1C155□
	2.2	20	0.5	11.8	TCFGP1C225□
	3.3	20	0.6	9.3	TCFGP1C335□
20	1.0	10	0.5	16.1	TCFGP1D105□
25	1.0	10	0.5	16.1	TCFGP1E105□

□=Capacitance tolerance (M:±20%)

TCFG Series: A Case (3216-18 [1206] Size)

Rated voltage (V)	Capacitance (μF)	tanδ at 120Hz(25°C) (%)	Leakage current (25°C, 5min) (A)	Impedance (at 100kHz) (Ω)	Part No.
4	4.7	6	0.5	5.6	TCFGA0G475□
	6.8	8	0.5	4.9	TCFGA0G685□
	10	8	0.5	4.2	TCFGA0G106□
	15	8	0.6	4.0	TCFGA0G156□
	22	8	0.9	3.0	TCFGA0G226□
	33	10	1.3	3.5	TCFGA0G336□
	47	12	1.9	3.2	TCFGA0G476□
	68	16	3.0	3.0	TCFGA0G686□
6.3	3.3	6	0.5	5.6	TCFGA0J335□
	4.7	8	0.5	4.9	TCFGA0J475□
	6.8	8	0.5	4.2	TCFGA0J685□
	10	8	0.6	4.0	TCFGA0J106□
	15	8	0.9	3.0	TCFGA0J156□
	22	10	1.4	3.5	TCFGA0J226□
	33	12	2.1	3.2	TCFGA0J336□
	47	18	3.0	3.2	TCFGA0J476□
10	1.5	6	0.5	8.8	TCFGA1A155□
	2.2	6	0.5	5.6	TCFGA1A225□
	3.3	8	0.5	4.9	TCFGA1A335□
	4.7	8	0.5	4.2	TCFGA1A475□
	6.8	8	0.7	4.0	TCFGA1A685□
	10	8	1.0	3.0	TCFGA1A106□
	15	10	1.5	3.5	TCFGA1A156□
	22	12	2.2	3.2	TCFGA1A226□
16	1.0	6	0.5	7.0	TCFGA1C105□
	1.5	6	0.5	5.6	TCFGA1C155□
	2.2	6	0.5	4.9	TCFGA1C225□
	3.3	6	0.5	4.8	TCFGA1C335□
	4.7	6	0.8	3.9	TCFGA1C475□
	6.8	6	1.1	3.8	TCFGA1C685□
	10	8	1.6	3.5	TCFGA1C106□
	20	1.0	6	0.5	7.0
1.5		6	0.5	6.0	TCFGA1D155□
2.2		6	0.5	5.2	TCFGA1D225□
3.3		6	0.7	4.8	TCFGA1D335□
4.7		6	0.9	3.9	TCFGA1D475□
25	1.0	6	0.5	7.0	TCFGA1E105□
	1.5	6	0.5	6.0	TCFGA1E155□
	2.2	6	0.6	5.2	TCFGA1E225□
	3.3	6	0.8	4.8	TCFGA1E335□
	4.7	8	1.2	3.4	TCFGA1E475□

□=Capacitance tolerance (M:±20%)

TCFG Series: B Case (3528-21 [1411] Size)

Rated voltage (V)	Capacitance (μF)	tanδ at 120Hz(25°C) (%)	Leakage current (25°C, 5min) (A)	Impedance (at 100kHz) (Ω)	Part No.
2.5	220	18	5.5	1.5	TCFGB0E227□
4	15	8	0.6	3.0	TCFGB0G156□
	22	8	0.9	3.0	TCFGB0G226□
	33	8	1.3	2.5	TCFGB0G336□
	47	10	1.9	2.0	TCFGB0G476□
	68	10	2.7	1.9	TCFGB0G686□
	100	12	4.0	1.6	TCFGB0G107□
	150	18	6.3	1.3	TCFGB0G157□
	220	20	8.8	1.3	TCFGB0G227□
6.3	10	8	0.6	3.0	TCFGB0J106□
	15	8	0.9	3.0	TCFGB0J156□
	22	8	1.4	2.5	TCFGB0J226□
	33	8	2.1	2.0	TCFGB0J336□
	47	10	3.0	1.9	TCFGB0J476□
	68	12	4.3	1.6	TCFGB0J686□
	100	12	6.3	1.6	TCFGB0J107□
	150	18	9.5	1.5	TCFGB0J157□
220	30	70	1.3	TCFGB0J227□	
10	4.7	6	0.5	3.0	TCFGB1A475□
	6.8	8	0.7	3.0	TCFGB1A685□
	10	8	1.0	3.0	TCFGB1A106□
	15	8	1.5	2.5	TCFGB1A156□
	22	8	2.2	2.0	TCFGB1A226□
	33	10	3.3	1.9	TCFGB1A336□
	47	10	4.7	1.6	TCFGB1A476□
	68	12	6.8	1.5	TCFGB1A686□
100	20	20.0	1.5	TCFGB1A107□	
16	3.3	6	0.5	4.2	TCFGB1C335□
	4.7	6	0.8	3.0	TCFGB1C475□
	6.8	6	1.1	3.0	TCFGB1C685□
	10	6	1.6	2.5	TCFGB1C106□
	15	6	2.4	2.0	TCFGB1C156□
	22	6	3.5	1.9	TCFGB1C226□
	33	14	5.3	1.9	TCFGB1C336□
	20	3.3	6	0.7	4.2
4.7		6	1.0	3.0	TCFGB1D475□
10		8	2.0	15.0	TCFGB1D106□
25		3.3	6	0.9	4.2
4.7	6	1.2	3.0	TCFGB1E475□	

□=Capacitance tolerance (M:±20%)

TCFG Series: C Case (6032-27 [2412] Size)

Rated voltage (V)	Capacitance (μF)	tanδ at 120Hz(25°C) (%)	Leakage current (25°C, 5min) (A)	Impedance (at 100kHz) (Ω)	Part No.
4	220	12	8.8	1.3	TCFGC0G227□
6.3	150	12	9.5	1.3	TCFGC0J157□
10	100	10	10.0	1.3	TCFGC1A107□
16	47	8	7.5	1.6	TCFGC1C476□
25	15	10	3.8	1.3	TCFGC1E156□

□=Capacitance tolerance (M:±20%)

TCFG Series: D Case (7343-30 [2917] Size)

Rated voltage (V)	Capacitance (μF)	tanδ at 120Hz(25°C) (%)	Leakage current (25°C, 5min) (A)	Impedance (at 100kHz) (Ω)	Part No.
4	330	14	13.2	0.7	TCFGD0G337□
6.3	220	12	13.8	0.7	TCFGD0J227□
10	150	10	15.0	0.7	TCFGD1A157□
16	100	10	16.0	0.7	TCFGD1C107□
25	47	10	11.8	0.7	TCFGD1E476□
35	22	10	7.7	0.8	TCFGD1V226□

□=Capacitance tolerance (M:±20%)

Dimensions

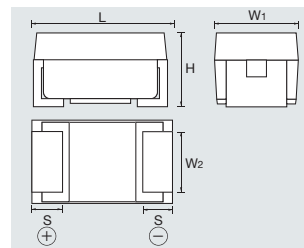

(Unit : mm)

Case (mm [inch])	L	W1	W2	H	S
P (2012-12 [0805])	2.0±0.2	1.25±0.2	0.9±0.2	1.2 Max.	0.45±0.3
A (3216-18 [1206])	3.2±0.2	1.6±0.2	1.2±0.2	1.6±0.2	0.8±0.3
B (3528-21 [1411])	3.5±0.2	2.8±0.2	1.9±0.2	1.9±0.2	0.8±0.3
C (6032-27 [2412])	6.0±0.2	3.2±0.2	2.2±0.1	2.5±0.2	1.3±0.2
D (7343-30 [2917])	7.3±0.2	4.3±0.2	2.4±0.1	2.8±0.2	1.3±0.2

# Standard Type



## TC Series

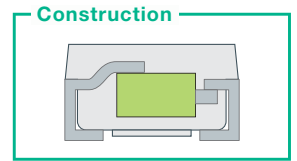

### Summary

Advanced semiconductor manufacturing technology developed for transistors and diodes are utilized for stable quality control and superior productivity. Available in two package types, P Case [2012-12 (0805) size] and A Case [3216-18 (1206) size], this lineup features large capacitance in a compact form factor.

### Features

- Compact

### Applications

PCs, PC peripherals, mobile phones, digital cameras, digital camcorders, and more.

### Lineup

P Case (2012-12 [0805])

Capacitance (μF)	Rated voltage(V, DC)					
	4	6.3	10	16	20	25
1.0 (105)			P	P	P	P
1.5 (155)		P	P	P		
2.2 (225)	P	P	P	P		
3.3 (335)	P	P	P	P		
4.7 (475)	P	P	P			
6.8 (685)	P	P	P			
10 (106)	P	P	P			
15 (156)	P	P				
22 (226)	P	P				
33 (336)	☆P					
47 (476)						
68 (686)						
100 (107)						

☆Under development

A Case (3216-18 [1206])

Capacitance (μF)	Rated voltage(V, DC)						
	4	6.3	10	16	20	25	35
1.0 (105)				A	A	A	☆A
1.5 (155)			A	A	A	A	
2.2 (225)			A	A	A	A	
3.3 (335)		A	A	A	A	A	
4.7 (475)	A	A	A	A	A	A	
6.8 (685)	A	A	A	A			
10 (106)	A	A	A	A			
15 (156)	A	A	A				
22 (226)	A	A	A				
33 (336)	A	A					
47 (476)	A	A					
68 (686)	A	A					
100 (107)	A						

☆Under development

### Dimensions

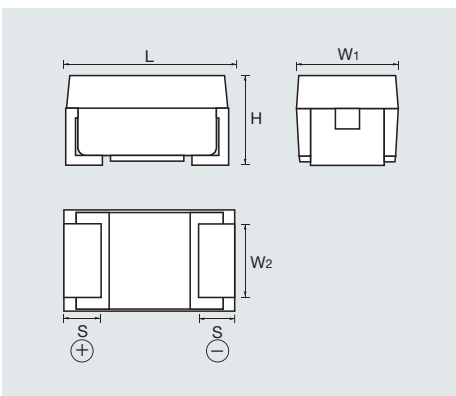

Case (mm [inch])	L	W1	W2	H	S
P (2012-12 [0805])	2.0±0.2	1.25±0.2	0.9±0.2	1.2 Max.	0.45±0.3
A (3216-18 [1206])	3.2±0.2	1.6±0.2	1.2±0.2	1.6±0.2	0.8±0.3

(Unit : mm)

## Quick Reference

TC Series: P Case (2012-12 [0805] Size)

Rated Voltage (V)	Capacitance (μF)	tanδ at 120Hz(25°C) (%)	Leakage current (25°C, 5min) (μA)	Impedance (at 100kHz) (Ω)	Part No.
4	2.2	10	0.5	17.5	TCP0G225□
	3.3	20	0.5	17.5	TCP0G335□
	4.7	20	0.5	14.4	TCP0G475□
	6.8	20	0.5	11.8	TCP0G685□
	10	20	0.5	9.3	TCP0G106□
	15	20	0.6	8.3	TCP0G156□
	22	20	0.9	7.7	TCP0G226□
	33	25	1.4	5.0	TCP0G336□
6.3	1.5	10	0.5	17.5	TCP0J155□
	2.2	20	0.5	17.5	TCP0J225□
	3.3	20	0.5	14.4	TCP0J335□
	4.7	20	0.5	11.8	TCP0J475□
	6.8	20	0.5	9.3	TCP0J685□
	10	20	0.6	8.3	TCP0J106□
	15	20	0.9	7.7	TCP0J156□
	22	25	1.4	5.0	TCP0J226□
10	1.0	10	0.5	17.5	TCP1A105□
	1.5	20	0.5	16.1	TCP1A155□
	2.2	20	0.5	14.4	TCP1A225□
	3.3	20	0.5	11.8	TCP1A335□
	4.7	20	0.5	9.3	TCP1A475□
	6.8	20	0.7	9.3	TCP1A685□
	10	20	1.0	7.7	TCP1A106□
16	1.0	10	0.5	16.1	TCP1C105□
	1.5	20	0.5	14.8	TCP1C155□
	2.2	20	0.5	11.8	TCP1C225□
	3.3	20	0.6	9.3	TCP1C335□
20	1.0	10	0.5	16.1	TCP1D105□
25	1.0	20	0.6	9.3	TCP1E105□

□=Capacitance tolerance (M:±20%)

TC Series: A Case (3216-18 [1206] Size)

Rated Voltage (V)	Capacitance (μF)	tanδ at 120Hz(25°C) (%)	Leakage current (25°C, 5min) (μA)	Impedance (at 100kHz) (Ω)	Part No.
4	4.7	6	0.5	5.6	TCA0G475□
	6.8	8	0.5	4.9	TCA0G685□
	10	8	0.5	4.2	TCA0G106□
	15	8	0.6	4.0	TCA0G156□
	22	8	0.9	3.0	TCA0G226□
	33	10	1.3	3.5	TCA0G336□
	47	12	1.9	3.2	TCA0G476□
	68	18	2.7	3.0	TCA0G686□
	100	30	4.0	3.0	TCA0G107□
	6.3	3.3	6	0.5	5.6
4.7		8	0.5	4.9	TCA0J475□
6.8		8	0.5	4.2	TCA0J685□
10		8	0.6	4.0	TCA0J106□
15		8	0.9	3.0	TCA0J156□
22		10	1.4	3.5	TCA0J226□
33		12	2.1	3.2	TCA0J336□
47		18	3.0	3.2	TCA0J476□
68		30	4.3	3.0	TCA0J686□
10		1.5	6	0.5	8.8
	2.2	6	0.5	5.6	TCA1A225□
	3.3	8	0.5	4.9	TCA1A335□
	4.7	8	0.5	4.2	TCA1A475□
	6.8	8	0.7	4.0	TCA1A685□
	10	8	1.0	3.0	TCA1A106□
	15	10	1.5	3.5	TCA1A156□
	22	12	2.2	3.2	TCA1A226□
16	1.0	6	0.5	7.0	TCA1C105□
	1.5	6	0.5	5.6	TCA1C155□
	2.2	6	0.5	4.9	TCA1C225□
	3.3	6	0.5	4.8	TCA1C335□
	4.7	6	0.8	3.9	TCA1C475□
	6.8	6	1.1	3.8	TCA1C685□
	10	8	1.6	3.5	TCA1C106□
	20	1.0	6	0.5	7.0
1.5		6	0.5	6.0	TCA1D155□
2.2		6	0.5	5.2	TCA1D225□
3.3		6	0.7	4.8	TCA1D335□
4.7		6	0.9	3.9	TCA1D475□
25	1.0	6	0.5	7.0	TCA1E105□
	1.5	6	0.5	6.0	TCA1E155□
	2.2	6	0.6	5.2	TCA1E225□
	3.3	6	0.8	4.8	TCA1E335□
	4.7	8	1.2	3.4	TCA1E475□
35	1.0	6	0.5	7.0	TCA1V105□

□=Capacitance tolerance (M:±20%)

# Recommended Soldering Conditions

## TCS/TCT/TCFG/TC Series

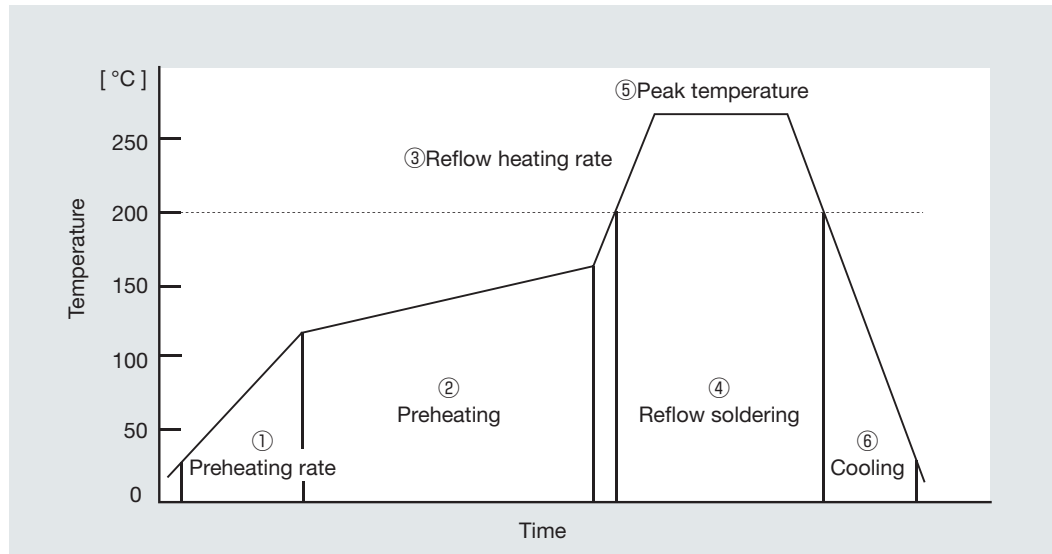

[ Recommended reflow soldering conditions ]

- ① Preheating rate : 1 to 5°C/s
- ② Preheating : 120 to 160°C , 50 to 120s
- ③ Reflow heating rate : 1 to 5°C/s
- ④ Soldering (high temperature period) : 200°C , 30 to 60s
- ⑤ Peak temperature : 230 to 260°C , 10s Max.
- ⑥ Cooling : 60s Min.
- ⑦ Reflow count : 2 times Max.

[ Recommended hand soldering conditions ]

- ① Solder tip temperature : 350°C max. (TCFG series 300°C max.)
- ② Time : 5s max.

\*The TCS and TCT series are not suitable for flow soldering.

## Recommended Land Pattern

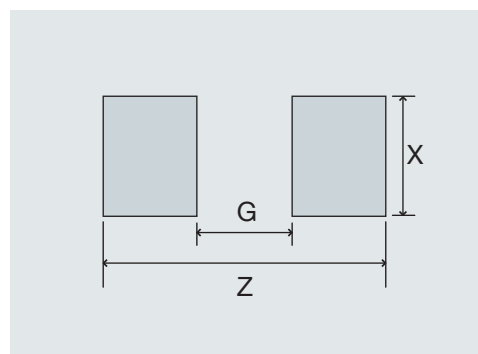

(Unit : mm)

Series	Case (mm [inch])	X	G	Z
TCS	M (1608-09 [0603])	0.65	0.9	2.3
	P (2012-12 [0805])	0.95	1.2	3.0
TCT	U (1005-06 [0402])	0.5	0.4	1.5
	PL (Low Profile 2012-10 [0805])	0.95	1.1	2.9
	P (2012-12 [0805])	0.95	1.1	2.9
	AS (Ultra-Low Profile 3216-10 [1206])	1.25	1.7	4.1
	AL (Low Profile 3216-12 [1206])	1.25	1.7	4.1
TCFG	CL (Low Profile 6032-12 [2412])	2.3	3.45	8.05
	P (2012-12 [0805])	1.1	0.8	3.4
	A (3216-18 [1206])	1.4	1.2	5.2
	B (3528-21 [1411])	2.7	1.4	5.6
TC	C (6032-27 [2412])	2.7	2.9	6.9
	D (7343-30 [2917])	2.9	4.1	8.2
	M (1608-09 [0603])	0.65	0.65	2.2
	P (2012-12 [0805])	1.1	0.8	3.4
	A (3216-18 [1206])	1.4	1.2	5.2

# Part Number Explanation

**T** **C**   **A** **0** **J** **1** **0** **6** **M** **8** **R**

Series name	Case style	Rated voltage	Capacitance tolerance	Code	Capacitance tolerance	Code	Tape width	Parts orientation
TCS	Case	Code	Nominal capacitance (pF) is denoted by 3 digits: 2 significant figures followed by a 3rd digit representing the number of zeroes that follow	M	±20%	B	8mm	R : Positive electrode on the side opposite to sprocket hole
TCT	Size (mm (inch))	Rated voltage (V)				C	12mm	
TCFG	U 1005-06 (0402)	0E 2.5						
TC	M 1608-09 (0603)	0G 4						
	PL Low Profile 2012-10 (0805)	0J 6.3						
	P 2012-12 (0805)	1A 10						
	AS Ultra-Low Profile 3216-10 (1206)	1C 16						
	AL Low Profile 3216-12 (1206)	1D 20						
	A 3216-18 (1206)	1E 25						
	B 3528-21 (1411)	1V 35						
	CL Low Profile 6032-12 (2412)							
	C 6032-27 (2412)							
	D 7343-30 (2917)							

# Taping Specifications

## Reel Dimensions and Quantity

Case (mm [inch])	Packing amount (pcs)	Tape width (mm)	Reel diameter (mm)	W1 (mm)	W2 (mm)			
U (1005-06 [0402])	10000	8.0±0.2	φ180	9.0	11.4			
M (1608-09 [0603])	TC					4000		
	TCS					3000		
PL (Low Profile 2012-10 [0805])	3000					12.0	13.0	15.4
P (2012-12 [0805])								
AS (Ultra-Low Profile 3216-10 [1206])								
AL (Low Profile 3216-12 [1206])								
A (3216-18 [1206])	2000					1000	13.0	15.4
B (3528-21 [1411])								
CL (Low Profile 6032-12 [2412])	500							
C (6032-27 [2412])								
D (7343-30 [2917])								

## Embossed Carrier Tape Specifications

(Unit : mm)

Case (mm [inch])	A	B	W	E±0.1	F	P1±0.1	P2	P0±0.1	D0	t1	t2
U (1005-06 [0402])	0.75±0.1	1.4±0.1	8.0±0.2	1.75	3.5±0.05	2.0	2.0±0.1	4.0	φ1.5	0.2±0.05	0.65±0.05
M (1608-09 [0603])	TC	1.0±0.1				1.85±0.1	φ1.5±0.1		1.0±0.1		
	TCS	1.15±0.1				2.0±0.1			1.1±0.1		
PL (Low Profile 2012-10 [0805])	1.6±0.1	2.4±0.1				0.25±0.05	φ1.5		1.05±0.05		
P (2012-12 [0805])	1.55±0.1	2.3±0.1							1.5±0.1 (TCS : 1.32±0.1)		
AS (Ultra-Low Profile 3216-10 [1206])	1.9±0.1	3.5±0.1							1.1±0.1		
AL (Low Profile 3216-12 [1206])	1.9±0.1	3.5±0.1							1.3±0.05		
A (3216-18 [1206])	1.9±0.1	3.5±0.1							1.9±0.1		
B (3528-21 [1411])	3.3±0.1	3.8±0.1							2.2±0.1		
CL (Low Profile 6032-12 [2412])	3.5±0.1	6.6±0.1				12.0±0.2	5.5±0.05		8.0	2.0±0.1	φ1.5±0.1
C (6032-27 [2412])	3.7±0.2	6.4±0.2	12.0±0.3	5.5±0.1	2.0±0.1	φ1.5	0.3±0.1	3.3±0.2			
D (7343-30 [2917])	4.8±0.2	7.7±0.2	12.0±0.3	5.5±0.1	2.0±0.1	φ1.5	0.3±0.1	3.3±0.2			

## Usage Precautions

- 1 Verification and confirmation of performance characteristics of products, after mounting on board, is strongly advised.
- 2 In particular, if a transient load (a large load applied in a short period of time, such as pulse) is applied, confirmation of performance characteristics after mounting on board is strongly recommended. Avoid applying power exceeding the normal rated power, since exceeding the power rating under steady state load conditions may negatively affect product performance and reliability.

### 3 Allowable ripple voltage

The sum of the peak values of DC and AC voltage should not exceed the rated voltage. The ripple voltage, if applied, should not exceed the maximum allowable value. The allowable ripple voltage at different temperatures is calculated using the formulas below.

$$E = \text{Allowable ripple voltage}$$

$$E \text{ Max. (at } 50^{\circ}\text{C)} = 0.7 \times E \text{ Max. (at } 25^{\circ}\text{C)}$$

$$E \text{ Max. (at } 85^{\circ}\text{C)} = 0.5 \times E \text{ Max. (at } 25^{\circ}\text{C)}$$

$$E \text{ Max. (at } 125^{\circ}\text{C)} = 0.3 \times E \text{ Max. (at } 25^{\circ}\text{C)}$$

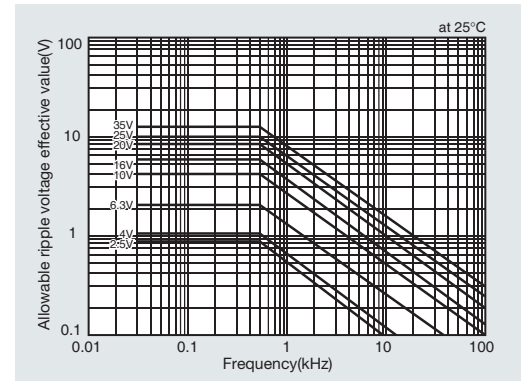

- 4 The voltage should be reduced as much as possible. In particular, a voltage lower than 1/3 of the rated voltage is recommended when used in a low impedance circuit.
- 5 The tester must not be in contact with a capacitor. If this occurs, an excessive or reverse voltage may be applied to the capacitor.
- 6 Please refer to the derating curve during operation from 85°C to 125°C.
- 7 Apply a series-resistor rated at 3Ω per 1V.
- 8 When a highly active halogenous (i.e. chlorine, bromine) flux is used, the remainder of flux may negatively affect product performance and reliability. Therefore, a halogen-free flux should be used.
- 9 Reflow soldering is recommended. However, if flow soldering will be performed please consult with ROHM in advance.
- 10 This section is concerned with accidental short-mode failures due to thermal, mechanical, and electrical stresses. Please note that failures can be delayed by reducing the ambient temperature, ripple current, and/or supply voltage.
- 11 Failures often occur in the circuits below. Therefore, their use is strictly prohibited.
  - a) High impedance voltage retention circuits
  - b) Coupling circuits
  - c) Circuits affected by current leakage
  - d) Series connection with loads exceeding the rated voltage
- 12 Bipolar connection is prohibited.
- 13 Please note that the electrical characteristics will fluctuate depending on the peripheral circuitry and frequency. Please take this into consideration during circuit design.

MEMO

The content specified in this document is correct as of **1st September, 2011**.

No copying or reproduction of this document, in part or in whole, is permitted without the consent of ROHM Co., Ltd.

The content specified herein is subject to change for improvement without notice.

The content specified herein is for the purpose of introducing ROHM's products (hereinafter "Products"). If you wish to use any such Product, please be sure to refer to the specifications, which can be obtained from ROHM upon request.

Examples of application circuits, circuit constants and any other information contained herein illustrate the standard usage and operations of the Products. The peripheral conditions must be taken into account when designing circuits for mass production.

Great care was taken in ensuring the accuracy of the information specified in this document. However, should you incur any damage arising from any inaccuracy or misprint of such information, ROHM shall bear no responsibility for such damage.

The technical information specified herein is intended only to show the typical functions of and examples of application circuits for the Products. ROHM does not grant you, explicitly or implicitly, any license to use or exercise intellectual property or other rights held by ROHM and other parties. ROHM shall bear no responsibility whatsoever for any dispute arising from the use of such technical information.

The Products specified in this document are intended to be used with general-use electronic equipment or devices (such as audio visual equipment, office-automation equipment, communication devices, electronic appliances and amusement devices).

The Products specified in this document are not designed to be radiation tolerant.

While ROHM always makes efforts to enhance the quality and reliability of its Products, a Product may fail or malfunction for a variety of reasons.

Please be sure to implement in your equipment using the Products safety measures to guard against the possibility of physical injury, fire or any other damage caused in the event of the failure of any Product, such as derating, redundancy, fire control and fail-safe designs. ROHM shall bear no responsibility whatsoever for your use of any Product outside of the prescribed scope or not in accordance with the instruction manual.

The Products are not designed or manufactured to be used with any equipment, device or system which requires an extremely high level of reliability the failure or malfunction of which may result in a direct threat to human life or create a risk of human injury (such as a medical instrument, transportation equipment, aerospace machinery, nuclear-reactor controller, fuel-controller or other safety device). ROHM shall bear no responsibility in any way for use of any of the Products for the above special purposes. If a Product is intended to be used for any such special purpose, please contact a ROHM sales representative before purchasing.

If you intend to export or ship overseas any Product or technology specified herein that may be controlled under the Foreign Exchange and the Foreign Trade Law, you will be required to obtain a license or permit under the Law.

## ROHM Sales Offices

Contact us for further information about the products.

<b>San Diego</b>	+1-858-625-3600	<b>Mexico</b>	+52-33-3123-2001	<b>Spain</b>	+34-9375-24320	<b>Singapore</b>	+65-6332-2322
<b>Atlanta</b>	+1-770-754-5972	<b>Brazil</b>	+55-11-3539-6320	<b>Hungary</b>	+36 1 950 5859	<b>Philippines</b>	+63-2-807-6872
<b>Boston</b>	+1-978-371-0382	<b>Dusseldorf</b>	+49-2154-921-0	<b>Russia</b>	+74 95 739 4174	<b>Thailand</b>	+66-2-254-4890
<b>Chicago</b>	+1-847-368-1006	<b>Stuttgart</b>	+49-711-7272370	<b>Seoul</b>	+82-2-8182-700	<b>Malaysia</b>	+60-3-7958-8355
<b>Dallas</b>	+1-972-473-3748	<b>France</b>	+33 (0) 1 40 60 87 30	<b>Dalian</b>	+86-411-8230-8549	<b>India</b>	+91-44-4352-0008
<b>Denver</b>	+1-303-708-0908	<b>United Kingdom</b>	+44-1-908-272400	<b>Shanghai</b>	+86-21-6279-2727	<b>Kyoto</b>	+81-75-365-1218
<b>Detroit</b>	+1-248-348-9920	<b>Espoo</b>	+358 400 222 382	<b>Shenzhen</b>	+86-755-8307-3008	<b>Yokohama</b>	+81-45-476-2121
<b>Nashville</b>	+1-615-620-6700	<b>Salo</b>	+358-2-7332234	<b>Hong Kong</b>	+852-2-740-6262		
<b>Sunnyvale</b>	+1-408-720-1900	<b>Oulu</b>	+358-400-726 124	<b>Taiwan</b>	+886-2-2500-6956		

Catalog No.54P6579E 1.2012 ROHM ©

R1111A

**ROHM Co., Ltd.**

21 Saiin Mizosaki-cho, Ukyo-ku,  
Kyoto 615-8585 Japan

TEL : +81-75-311-2121 FAX : +81-75-315-0172

[www.rohm.com](http://www.rohm.com)

**ROHM**  
SEMICONDUCTOR