

## Capacitive Sensor Control IC Series



# Capacitive Sensor Switch Control IC

## BU21008MUV

### ●Description

BU21008MUV are the capacitive sensor controller with 16 channels respectively. Half of sensor ports are available to use to LED driver with PWM function. PWM function can control light ambient. Also gesture function can recognize the short touch, long touch and finger motion.

### ●Features

- 1) Gesture function
- 2) LED driver with PWM available
- 3) 2 wire serial interface
- 4) Power supply = 2.5V to 3.3V, I/O power supply = 1.7V to 3.3V
- 5) Integrated 10bit AD converter, clock and reset
- 6) Package VQFN032V5050

### ●Applications

It is possible to use it widely as a switch such as a Mobile phone, Portable equipment, and Audiovisual apparatuses.

### ●Absolute Maximum Ratings (Ta=25°C)

PARAMETER	SYMBOL	RATING		UNIT
		MIN	MAX	
APPLIED VOLTAGE	AVDD	-0.3	4.5	V
	DVDD	-0.3	4.5	
INPUT VOLTAGE	V <sub>A</sub> IN	-0.3	AVDD + 0.3	V
	V <sub>D</sub> IN	-0.3	DVDD + 0.3	
STORAGE TEMPERATURE RANGE	T <sub>stg</sub>	-55	125	°C
POWER DISSIPATION	P <sub>d</sub>	304		mW

Ambient temperature reduces a permission loss by 3.1mW per case more than 25 degrees Celsius, 1 degree Celsius.

● Recommended Operating conditions

PARAMETER	SYMBOL	RATING			UNIT
		MIN	TYP	MAX	
APPLIED VOLTAGE	AVDD	2.5	3.0	3.3	V
	DVDD	1.7	3.0	3.3	V
OPERATING TEMPERATURE RANGE	$T_{opr}$	-40	25	85	°C

● Electrical characteristics (Especially,  $T_{opr}=25^{\circ}\text{C}$  and  $AVDD=DVDD=0$  as long as it doesn't specify it.)

PARAMETER	SYMBOL	RATING			UNIT	Condition	
		MIN	TYP	MAX			
H INPUT VOLTAGE	$V_{IHIO}$	DVDD x 0.8	-	DVDD + 0.3	V		
L INPUT VOLTAGE	$V_{LlIO}$	DVSS - 0.3	-	DVDD x 0.2	V		
Output "H" voltage	$V_{OHIO}$	DVDD - 0.7	-	DVDD	V	$I_{OH}=-2[\text{mA}]$ . Overshoot is excluded.	
Output "L" voltage	$V_{OLLED}$	AVSS	-	0.5	V	$I_{OL}=8[\text{mA}]$ . Undershoot is excluded. LED output. $I_{OL}=3[\text{mA}]$ . Undershoot is excluded. SDA/TXD application. $I_{OL}=2[\text{mA}]$ . Undershoot is excluded. INT application.	
	$V_{OLTxD}$	DVSS	-	0.5			DVDD > 2[V]
				DVDD x 0.3			DVDD ≤ 2[V]
$V_{OLINT}$	DVSS	-	0.5				
Input leakage current	$I_{IZ}$	-1	-	1	μA		
Off leakage current	$I_{OZ}$	-1	-	1	μA		
Standby current	$I_{ST}$	-	-	2	μA	Shutdown (SDN="L")	
Current of operation	$I_{DD}$	-	300	-	μA		

● A/D Converter

PARAMETER	SYMBOL	RATING			UNIT	Condition
		MIN	TYP	MAX		
Resolution		-	10	-	bit	
Analog Input voltage	$V_{AIN}$	AVSS	-	AVDD	V	
change clock frequency	$f_{adck}$	0.2	-	2.0	MHz	
change time	$t_{tim}$	-	77	-	μsec	$f_{adck} = 1[\text{MHz}]$
Zero scale voltage		-	-	AVSS + 0.07	V	
full scale voltage		AVDD - 0.07	-	-	V	
differential Non line accurate	DNL	-	-	±3	LSB	
Integrate Non line accurate	INL	-	-	±3	LSB	

● CR Oscillator characteristic

PARAMETER	SYMBOL	RATING			UNIT	Condition
		MIN	TYP	MAX		
Frequency Oscillation	$f_{cr}$	0.4	0.8	2.0	MHz	

●Block Diagram, Pin configuration

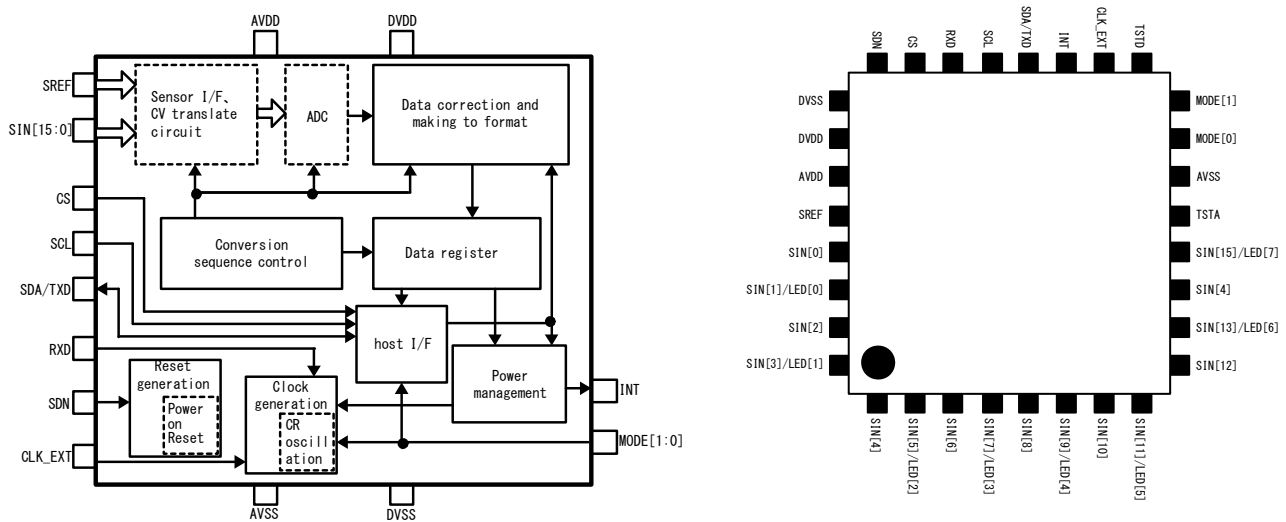

- **Sensor I/F CV translate circuit**  
This module selects between sensor inputs. The selection sequences between all 16 channels.
- **AD Conversion**  
The voltage into which CV is converted is converted into a digital value. Conversion is 10 bit and full scale corresponds to AVDD.
- **Conversion sequence control**  
Performs timing generation for the analogue circuitry and a sequencer circuit for selection of the sensor channel for conversion.
- **Data correction and making to format**  
This module provides the digital intelligence of the sensor. The block includes, amongst other things, scaling, adding offsets and input filtering for de-bouncing. Registers are formatted to simplify usage by the software application. The block implements auto-calibration to manage drift in temperature, process variation, voltage variation and aging effects.
- **Data register**  
This stores the results for the software application. Please refer to the register map for details.
- **HOST I/F**  
2 wire serial interface.
- **Power management**  
The power management block provides smart power control. When the sensors are not in use, the Controller automatically transitions into a low-power mode. When a sensor is touched, then the device automatically wakes up and enters its normal operation. The chip drives an INT pin for alerting the controller device in this case.
- **Reset generation**  
The circuit is initialized by a either a soft reset command or by the external SDN pin.
- **Clock generation**  
The device has an internal oscillator. Provision is also made if the application would like to make use of an external clock input.

● Pin Description

Pin No.	Name	I/O	Function	Note	Supply Reference	Reset Level	I/O Pad
1	SIN4	Aln	sensor input4	-	AVDD	"Hi-Z"	④
2	SIN5/LED2	Aln/Out	sensor input 5/PW Drive LED control output 2	sensor input , LED drive select	AVDD	"Hi-Z"	④
3	SIN6	Aln	sensor input6	-	AVDD	"Hi-Z"	④
4	SIN7/LED3	Aln/Out	sensor input 7/PWM Drive LED control output 3	sensor input , LED drive select	AVDD	"Hi-Z"	④
5	SIN8	Aln	sensor input8	-	AVDD	"Hi-Z"	④
6	SIN9/LED4	Aln/Out	sensor input 9 /LED control output 4	sensor input , LED drive select	AVDD	"Hi-Z"	④
7	SIN10	Aln	sensor input10	-	AVDD	"Hi-Z"	④
8	SIN11/LED5	Aln/Out	sensor input 11/LED control output 5	sensor input , LED drive select	AVDD	"Hi-Z"	④
9	SIN12	Aln	sensor input12	-	AVDD	"Hi-Z"	④
10	SIN13/LED6	Aln/Out	sensor input 13/LED control output 6	sensor input , LED drive select	AVDD	"Hi-Z"	④
11	SIN14	Aln	sensor input14	-	AVDD	"Hi-Z"	④
12	SIN15/LED7	Aln/Out	sensor input 15/LED control output 7	sensor input , LED drive select	AVDD	"Hi-Z"	④
13	TSTA	Aln	Test input for analog block	NC on the substrate is recommended.	AVDD	"Hi-Z"	④
14	AVSS	Ground	Analog ground	-	-	-	-
15	MODE[0]	In	Mode selection, input0	00 = 2wires serial, internal clock	DVDD	-	①
16	MODE[1]	In	Mode selection, input1		DVDD	-	①
17	TSTD	In	Digital part test input	Usually must be tide to "L"	DVDD	-	①
18	CLK_EXT	In	External system clock input	Usually tide to "L"	DVDD	-	①
19	INT	Out	Output of interrupt	"L" : Active mode "H" : Idle mode ※2	DVDD	"L"	③
20	SDA/TXD	In/Out	Communication data sending and receiving (2wires serial)	-	DVDD	"Hi-Z" -	⑤ ②
21	SCL	In	Communication synchronous clock input	-	DVDD	-	②
22	RXD	In	system clock input(2wires serial)	"L" : Internal clock "H" : external clock	DVDD	-	②
23	CS	In	Slave address selection (2wires serial mode)	"L" : 5Ah "H" : 5Bh	DVDD	-	②
24	SDN	In	Shutdown input	"L" : Halt condition "H" : state of operation	DVDD	-	-
25	DVSS	Ground	Digital part ground	-	-	-	-
26	DVDD	Power	Digital part Power supply	-	-	-	-
27	AVDD	Power	Analog part Power supply	-	-	-	④
28	SREF	Aln	Standard capacitor input	-	AVDD	"Hi-Z"	④
29	SIN0	Aln	sensor input 0	-	AVDD	"Hi-Z"	④
30	SIN1/LED0	Aln/Out	sensor input 1/PWM Drive LED control output 0	sensor input , LED drive select	AVDD	"Hi-Z"	④
31	SIN2	Aln	sensor input 2		AVDD	"Hi-Z"	④
32	SIN3/LED1	Aln/Out	sensor input 3/PWM Drive LED control output 1	sensor input , LED drive select	AVDD	"Hi-Z"	④

\*1 Initial State When internal organs power-on reset is effective

Halt condition SDN="L"

● I/O Circuit

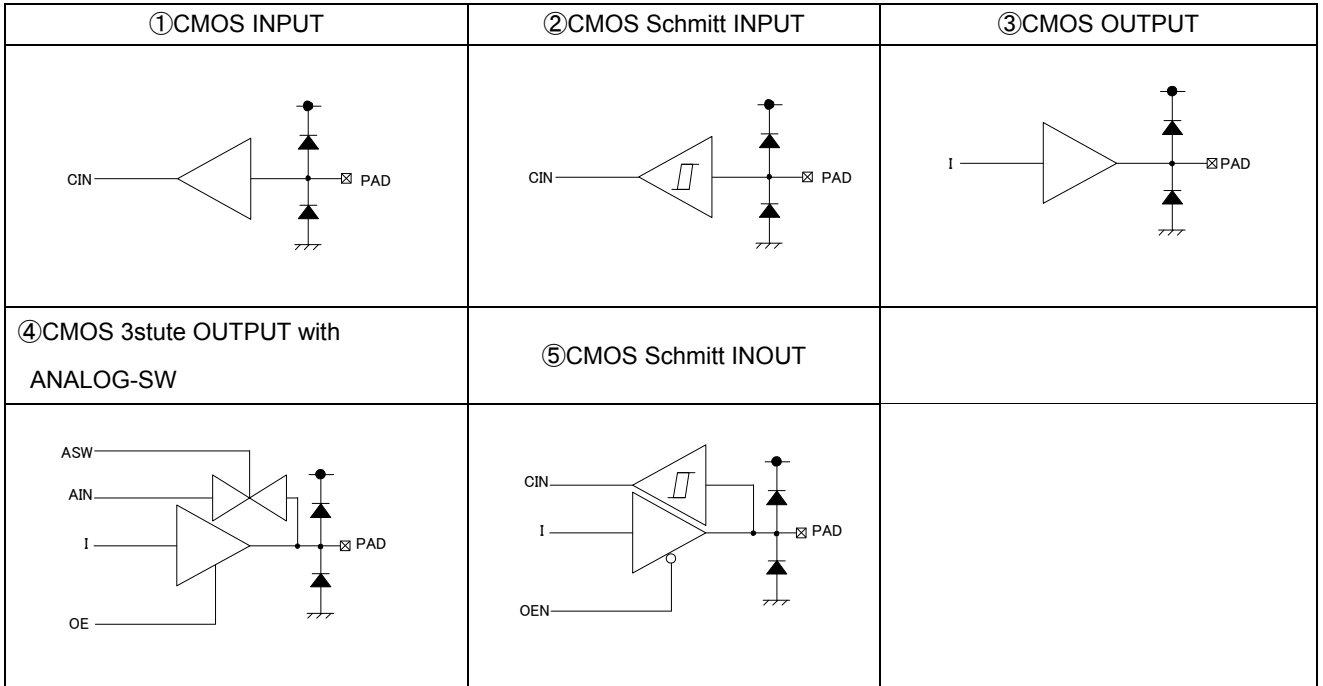

● HOST I/F

- 2 wire serial, BUS (Pin configuration, MODE[1:0]=00b)
  - Slave mode only
  - Slave Address = 5Ah,5Bh selection possible.
  - Normal (Normal mode. 100kHz Transfer rate)
  - Fs mode (Fast mode. 400kHz Transfer rate) also.
  - Not adapting sequential read / write.

【Data format】

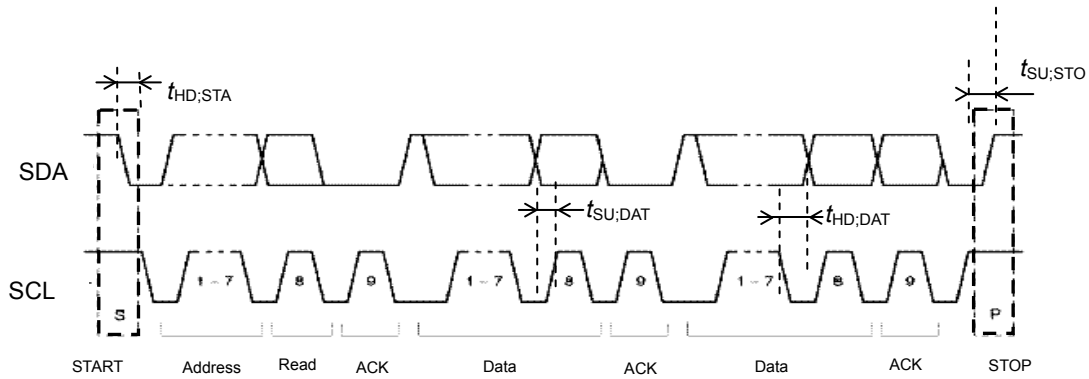

Parameter	Standard mode		High Speed mode		Unit
	MIN	MAX	MIN	MAX	
fSCL : SCL Clock Freq	0	100	0	400	kHz
t <sub>HD,STA</sub> : START condition hold time	4.0	-	0.6	-	μsec
t <sub>LOW</sub> : SCL "L"	4.7	-	1.3	-	μsec
t <sub>HIGH</sub> : SCL "H"	4.0	-	0.6	-	μsec
t <sub>HD,DAT</sub> : Data hold time	0.1	3.45	0.1	0.9	μsec
t <sub>SU,DAT</sub> : Data setup time	0.25	-	0.1	-	μsec
t <sub>SU,STO</sub> : START condition hold time	4.0	-	0.6	-	μsec
t <sub>BUF</sub> : Free time of bus between STOP condition and START condition	4.7	-	1.3	-	μsec

**【PROTOCOL】**

• Write Protocol



• Read Protocol

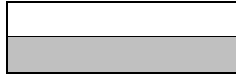
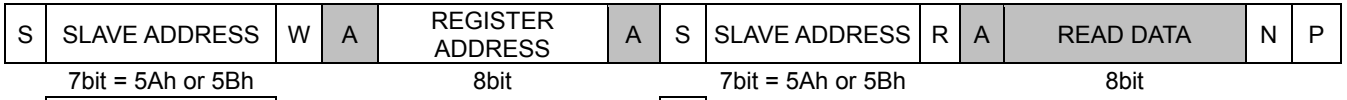

from Master to Slave  
from Slave to Master

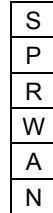

= START condition  
= STOP condition  
= data direction READ (SDA HIGH)  
= data direction WRITE (SDA LOW)  
= acknowledge (SDA LOW)  
= not acknowledge (SDA HIGH)

● Register map

Address	Register name	R/W	Length	Explanation
1*h	SENS_DATA	R	1byte / channel	Sensor output data. One for each channel.
32h, 33h	BTN	R	2byte	Button On/Off.
35h	BTN_STATE	R	1byte	Button state data.
4*h	OFFSET	R	1byte / channel	Offset correction data. One for each channel.
60h, 61h	GES_VEL	R	2byte	Gesture duration.
62h	GES_DIR	R	1byte	Gesture direction.
E0h	FEAD_CTL	W	1byte	PWM control setting.
E1h	FEAD_CLK	W	1byte	PWM clock setting.
E2h	GES_CLR	W	1byte	Gesture clear control.
E3h	GES_CTL	W	1byte	Gesture control.
E4h	GES_CLK	W	1byte	Gesture clock setting.
E5h	GES_TIMEOUT	W	1byte	Gesture time-out data setting.
E6h	GES_TEST	W	1byte	Gesture test function.
EEh	CALIB	W	1byte	Soft calibration execution.
EFh	DONE	W	1byte	Setting done command.
F0h, F1h	SENS_CH	W	2byte	Sensor channel enables.
F2h	LED_CH	W	1byte	LED channel enables.
F3h, F4h	IDLE_CH	W	2byte	Idle mode release control.
F5h	LED_LINK	W	1byte	LED linkage to sensor input.
F6h	TIMES	W	1byte	Defines the sampling interval and number of samples required to recognize a button press.
F7h	TH_ON2	W	1byte	A second threshold value in the detection of a button going from OFF state to ON state.
F8h, F9h	TH_ON2_CH	W	2byte	Per channel selection of whether to use TH_ON or TH_ON2.
FAh	CMD	W	1byte	Simultaneous press and idle mode entry.
FBh	GAIN_FILTER	W	1byte	Gain setting, filter function.
FCh	TH_ON	W	1byte	A threshold value in the detection of a button going from OFF state to ON state.
FDh	TH_OFF	W	1byte	A threshold value in the detection of a button going from ON state to OFF state.
FEh	DLED	W	1byte	Register to allow simple writing to LEDs.

**【1\*h : Sensor Output Data】**

Name: SENS\_DATA

Address: 1\* h (one byte per sensor channel)

Description: The sensor output that converts to 10bit. Scaling, offsets and filtering (when enabled) are applied. The most significant 8 bits are presented to the software with this register.

	Bit7	Bit6	Bit5	Bit4	Bit3	Bit2	Bit1	Bit0
1*h	SD *[7]	SD *[6]	SD *[5]	SD *[4]	SD *[3]	SD *[2]	SD *[1]	SD *[0]
R/W	R	R	R	R	R	R	R	R
Initial val.	1	0	0	0	0	0	0	0

**【32h / 33h : Button On/Off】**

Name: BTN

Address: 32h, 33h

Description: This is the state of the sensor when considered as an ON/OFF button. Here 1 : On. 0 :Off.

	Bit7	Bit6	Bit5	Bit4	Bit3	Bit2	Bit1	Bit0
32h	CH7	CH6	CH5	CH4	CH3	CH2	CH1	CH0
33h	CH15	CH14	CH13	CH12	CH11	CH10	CH9	CH8
R/W	R	R	R	R	R	R	R	R
Initial val.	0	0	0	0	0	0	0	0

**【35h : Button State Data】**

Name: BTN\_STATE

Address: 35h

Description: This provides information about the press.

**CH[3:0] : Effective channel :**

This indicates which button is dominant.

**SIMUL : Button effective :**

This indicates that the effective channel corresponds to a valid button press according to the thresholds. 1 : On. 0 : Off.

**CONTINU : A push and hold is effective :**

Indicates that the button was pressed and held for more than push/hold judgment time. 1 : On. 0 : Off.

	Bit7	Bit6	Bit5	Bit4	Bit3	Bit2	Bit1	Bit0
35h	CONTINU	-	-	SIMUL	CH[3]	CH[2]	CH[1]	CH[0]
R/W	R	-	-	R	R	R	R	R
Initial val.	0	-	-	0	0	0	0	0

**【4\* h : Offset Correction Data】**

Name: OFFSET

Address: 4\* h (one byte per sensor channel)

Description: This is the offset required to correct the sense data to half scale during the calibration procedure.

	Bit7	Bit6	Bit5	Bit4	Bit3	Bit2	Bit1	Bit0
4*h	OFS *[7]	OFS *[6]	OFS *[5]	OFS *[4]	OFS *[3]	OFS *[2]	OFS *[1]	OFS *[0]
R/W	R	R	R	R	R	R	R	R
Initial val.	1	0	0	0	0	0	0	0

**【60h / 61h : Gesture Duration】**

Name: GES\_VEL

Address: 60h, 61h

Description: Indicates the duration of the gesture in number of internal clocks. The count is a clock set with 0xE4(GES\_CLK).

It is possible to count up to 0~4095 clocks.

$$\text{Gesture duration} = (\text{gesture sampling interval}) * \text{VEL} [\text{sec}]$$

	Bit7	Bit6	Bit5	Bit4	Bit3	Bit2	Bit1	Bit0
60h	VEL[7]	VEL[6]	VEL[5]	VEL[4]	VEL[3]	VEL[2]	VEL[1]	VEL[0]
61h	-	-	-	-	VEL[11]	VEL[10]	VEL[9]	VEL[8]
R/W	R	R	R	R	R	R	R	R
Initial val.	0	0	0	0	0	0	0	0

**[62h : Gesture Direction Judgment]**

Name: GES\_DIR  
 Address: 62h  
 Description: Gesture direction judgment

**DIR\_A : gesture direction A**

0xE3(GES\_CTL) reference

**DIR\_B : gesture direction B**

0xE3(GES\_CTL) reference

	Bit7	Bit6	Bit5	Bit4	Bit3	Bit2	Bit1	Bit0
62h	-	-	-	-	-	-	DIR_B	DIR_A
R/W	-	-	-	-	-	-	R	R
Initial val.	-	-	-	-	-	-	0	0

**[E0h : PWM Control Setting]**

Name: FEAD\_CTRL  
 Address: E0h

Description: The following LEDs can be output as PWM - LED0, LED1, LED2, and LED3.

**EN : enable**

When the LED port is used as PWM, 1 is written. LED0 = EN[0], LED 1= EN[1], LED2 = EN[2], LED3 = EN[3].

**MODE : mode**

The mode of PWM is selected from four kinds.

mode	MODE	Fade in	Fade out
1	0 0	None	Fig 1
2	0 1	Fig 2	Fig 1
3	1 0	None	Fig 3
4	1 1	Fig 4	Fig 3

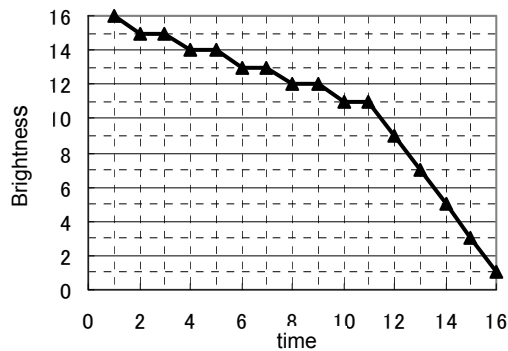

Fig 1.

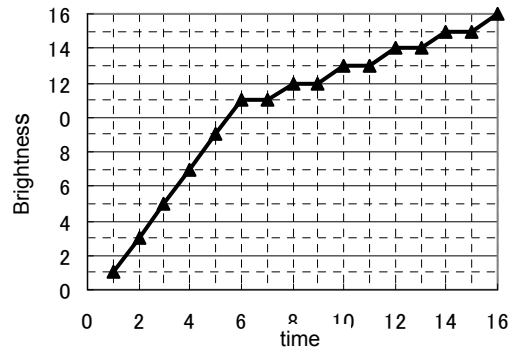

Fig 2.

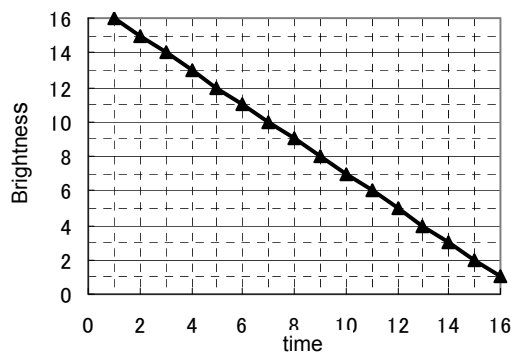

Fig 3.

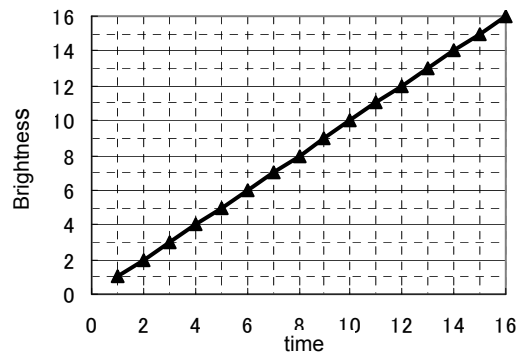

Fig 4.

	Bit7	Bit6	Bit5	Bit4	Bit3	Bit2	Bit1	Bit0
E0h	-	-	MODE[1]	MODE[0]	EN[3]	EN[2]	EN[1]	EN[0]
R/W	-	-	W	W	W	W	W	W
Initial val.	-	-	0	0	1	1	1	1

**【E1h : PWM Clock Setting】**

Name: FEAD\_CLK  
Address: E1h

Description: This register defines the divide ratio of the clock used for PWM. This also relates to the fade-in and fade-out time according to the following relationship.

$$\text{Fead in/out} = 1 / ( ( \text{Internal oscillation frequency} ) / ( 2 * 16 * 16 * 16 * ( F\_DIV + 1 ) * 16 ) ) [\text{sec}]$$

For example with an internal clock of 1.1MHz possible range is 0.119~1.906 [sec]

	Bit7	Bit6	Bit5	Bit4	Bit3	Bit2	Bit1	Bit0
<b>E1h</b>	-	-	-	-	F_DIV[3]	F_DIV[2]	F_DIV[1]	F_DIV[0]
<b>R/W</b>	-	-	-	-	W	W	W	W
<b>Initial val.</b>	-	-	-	-	0	1	1	1

**【E2h : Gesture Clear】**

Name: GES\_CLR  
Address: E2h

Description: This register when written to clears GES\_VEL and GES\_DIR. It is cleared by one, and it returns to 0 by the automatic operation.

	Bit7	Bit6	Bit5	Bit4	Bit3	Bit2	Bit1	Bit0
<b>E2h</b>	CLR	-	-	-	-	-	-	-
<b>R/W</b>	W	-	-	-	-	-	-	-
<b>Initial val.</b>	0	-	-	-	-	-	-	-

**【E3h : Gesture Function Setting】**

Name: GES\_CTL  
Address: E3h

Description: This register controls what key-press sequence is recognized as a gesture. Only 4 channels may be used - SIN0, SIN2, SIN4, and SIN6.

**EN : enable**

These are the enable bits. One is provided for each of the 4 sense inputs used for gesture. EN[0] is for SN0, EN[1] is for SN2, EN[2] is for SN4 and EN[3] is for SN6. 1 is to enable and 0 is for disable.

**MODE : mode**

0 : Requires all sensors to be present in the sequence before the gesture is recognized. (All detection mode)

1 : Allows one or more of the keys to be missed in the sequence. (Verbose mode)

The condition and the direction of detection that can be detected in each mode are as follows.

mode	MODE	Direction (GES_DIR)	Detected
All detection	0	DIR_A	1)SIN0→SIN2→SIN4→SIN6
		DIR_B	1)SIN6→SIN4→SIN2→SIN0
Verbose	1	DIR_A	1)SIN0→SIN2→SIN4
			2)SIN0→SIN2→ SIN6
	DIR_B	3) SIN2→SIN4→SIN6	
		4)SIN0→ SIN4	
DIR_A	5) SIN2→ SIN6		
	DIR_B	1)SIN6→SIN4→SIN2	
2)SIN6→SIN4→ SIN0			
DIR_B	3) SIN4→SIN2→SIN0		
	4)SIN6→ SIN2		
DIR_A	5) SIN4→ SIN0		

	Bit7	Bit6	Bit5	Bit4	Bit3	Bit2	Bit1	Bit0
<b>E3h</b>	-	-	-	MODE	EN[3]	EN[2]	EN[1]	EN[0]
<b>R/W</b>	-	-	-	W	W	W	W	W
<b>Initial val.</b>	-	-	-	1	1	1	1	1

**【E4h : Gesture Clock Setting】**

Name: GES\_CLK  
Address: E4h

Description: This register allows setting of the time base for the gesture detection. It sets a divide ratio of the clock used. The maximum judgment time and the sampling interval of the gesture can be set by changing this clock.

Gesture sampling interval =

$$1 / (( \text{Internal oscillation frequency} ) / ( 2 * 16 * 16 ) * 1 [\text{sec}] \quad \dots \text{ G\_DIV} = 0$$

$$1 / (( \text{Internal oscillation frequency} ) / ( 2 * 16 * 16 ) * 2 [\text{sec}] \quad \dots \text{ G\_DIV} = 1$$

$$1 / (( \text{Internal oscillation frequency} ) / ( 2 * 16 * 16 ) * 4 [\text{sec}] \quad \dots \text{ G\_DIV} = 2$$

$$1 / (( \text{Internal oscillation frequency} ) / ( 2 * 16 * 16 ) * 8 [\text{sec}] \quad \dots \text{ G\_DIV} = 3$$

Gesture maximum judgment time = (Gesture sampling interval) \* TO \* 16 [sec]

For example with an internal clock of 1.1MHz

G_DIV	Gesture sampling interval [msec]	Gesture maximum judgment time [sec]
0	0.46	1.90
1	0.93	3.81
2	1.86	7.62
3	3.72	15.2

	Bit7	Bit6	Bit5	Bit4	Bit3	Bit2	Bit1	Bit0
<b>E4h</b>	-	-	-	-	-	-	G_DIV[1]	G_DIV[0]
<b>R/W</b>	-	-	-	-	-	-	W	W
<b>Initial val.</b>	-	-	-	-	-	-	1	0

**【E5h : Gesture Timeout Data Setting】**

Name: GES\_TIMEOUT  
Address: E5h

Description: The maximum judgment time of the gesture is set. A key sequence which exceeds this time is not recognized.

Gesture Maximum Judgment Time = (Gesture sampling interval) \* TO \* 16 [sec]

	Bit7	Bit6	Bit5	Bit4	Bit3	Bit2	Bit1	Bit0
<b>E5h</b>	TO[7]	TO[6]	TO[5]	TO[4]	TO[3]	TO[2]	TO[1]	TO[0]
<b>R/W</b>	W	W	W	W	W	W	W	W
<b>Initial val.</b>	1	1	1	1	1	1	1	1

**【E6h : Gesture Test Setting】**

Name: GES\_TIMEOUT  
Address: E6h

Description: When this test bit is enabled (1) then the lower 4 bits of 0xFE(DLED) are used for the gesture recognition instead of the sensor inputs.

	Bit7	Bit6	Bit5	Bit4	Bit3	Bit2	Bit1	Bit0
<b>E6h</b>	-	-	-	-	-	-	-	TEST
<b>R/W</b>	-	-	-	-	-	-	-	W
<b>Initial val.</b>	-	-	-	-	-	-	-	0

**【EEh : Soft Calibration】**

Name: CALIB  
Address: EEh

Description: This forces a chip re-calibration when a 1 is written and returns to 0 afterward automatically. Please note that one should always re-calibrate after changing the gain adjustment value.

	Bit7	Bit6	Bit5	Bit4	Bit3	Bit2	Bit1	Bit0
<b>EEh</b>	-	-	-	-	-	-	-	CALIB
<b>R/W</b>	-	-	-	-	-	-	-	W
<b>Initial val.</b>	-	-	-	-	-	-	-	0

**【EFh : Setting Done, Detect Start】**

Name: DONE

Address: EFh

Description: This register should be written to following register updates.

	Bit7	Bit6	Bit5	Bit4	Bit3	Bit2	Bit1	Bit0
EFh	-	-	-	-	-	-	-	DONE
R/W	-	-	-	-	-	-	-	W
Initial val.	-	-	-	-	-	-	-	0

**【F0h / F1h : Sensor Channel Setting】**

Name: SENS\_CH

Address: F0h / F1h

Description: Individual enabling and disabling of sensor channels. 1 : Effective 0 : Not in use

	Bit7	Bit6	Bit5	Bit4	Bit3	Bit2	Bit1	Bit0
F0h	SIN7	SIN6	SIN5	SIN4	SIN3	SIN2	SIN1	SIN0
F1h	SIN15	SIN14	SIN13	SIN12	SIN11	SIN10	SIN9	SIN8
R/W	W	W	W	W	W	W	W	W
Initial val.	0	0	0	0	0	0	0	0

**【F2h : LED Channel Setting】**

Name: LED\_CH

Address: F2h

Description: Enables and disables the channels to be used as LED outputs. Valid for the 8 LED outputs. 1 : Effective 0 : Not in use

	Bit7	Bit6	Bit5	Bit4	Bit3	Bit2	Bit1	Bit0
F2h	LED7	LED6	LED5	LED4	LED3	LED2	LED1	LED0
R/W	W	W	W	W	W	W	W	W
Initial val.	0	0	0	0	0	0	0	0

**【F3h / F4h : Idle Exit Condition】**

Name: IDLE\_CH

Address: F3h / F4h

Description: Defines which channels cause the device to wake up – i.e. go from idle mode to normal operation on a key press. Selection is made on a per channel basis.  
1 : Effective 0 : Not used

	Bit7	Bit6	Bit5	Bit4	Bit3	Bit2	Bit1	Bit0
F3h	SIN7	SIN6	SIN5	SIN4	SIN3	SIN2	SIN1	SIN0
F4h	SIN15	SIN14	SIN13	SIN12	SIN11	SIN10	SIN9	SIN8
R/W	W	W	W	W	W	W	W	W
Initial val.	1	1	1	1	1	1	1	1

**【F5h : LED to Sensor Linkage】**

Name: LED\_LINK

Address: F5h

Description: Allows the LED outputs to be automatically linked to the input channels without need for any software control.  
1 : It synchronizes with the button. 0 : It synchronizes with data (The register name: DLED) from host.

	Bit7	Bit6	Bit5	Bit4	Bit3	Bit2	Bit1	Bit0
F5h	LED7	LED6	LED5	LED4	LED3	LED2	LED1	LED0
R/W	W	W	W	W	W	W	W	W
Initial val.	1	1	1	1	1	1	1	1

**[F6h : Sampling Interval and Number of Samples Used for Button Press]**

Name: TIMES  
Address: F6h

Description: Defines the sampling interval and number of samples required to recognise as a button press.

**CONT\_T[3:0] : Push and hold judgment time :**

Governs how long it is before the chip decides it is push and hold. Given by the following equation:

Push-Hold Time = system clock x  $2^{19}$  x CONT\_T (Example: system clock 1[MHz] time : About 520[msec]).

**SAMP[3:0] : Sampling Interval :**

Given by the following equation:

Sampling interval = system clock x  $2^{13}$  x SAMP (Example: system clock 1[MHz] time : About 8.2[msec]).

	Bit7	Bit6	Bit5	Bit4	Bit3	Bit2	Bit1	Bit0
<b>F6h</b>	CONT_T[3]	CONT_T[2]	CONT_T[1]	CONT_T[0]	SAMP[3]	SAMP[2]	SAMP[1]	SAMP[0]
<b>R/W</b>	W	W	W	W	W	W	W	W
<b>Initial val.</b>	0	0	0	0	0	0	0	0

**[F7h : Button OFF→ON Threshold]**

Name: TH\_ON2  
Address: F7h

Description: A second threshold value for determining a button off→on judgment of sensor. The sensor output value of 8bit (register SENS\_DATA) is compared with 128+ ON2 [6:0], and if it is larger, the button is determined active.

	Bit7	Bit6	Bit5	Bit4	Bit3	Bit2	Bit1	Bit0
<b>F7h</b>	-	ON2[6]	ON2[5]	ON2[4]	ON2[3]	ON2[2]	ON2[1]	ON2[0]
<b>R/W</b>	-	W	W	W	W	W	W	W
<b>Initial val.</b>	-	0	0	1	0	0	0	0

**[F8h / F9h : Button OFF→ON Threshold Selection]**

Name: TH\_ON2\_CH  
Address: F8h / F9h

Description: This register is used to relate either threshold TH\_ON or TH\_ON2 to particular sensor channels for button press activity determination.

1 : TH\_ON2 is applied 0 : TH\_ON is applied

	Bit7	Bit6	Bit5	Bit4	Bit3	Bit2	Bit1	Bit0
<b>F8h</b>	SIN7	SIN6	SIN5	SIN4	SIN3	SIN2	SIN1	SIN0
<b>F9h</b>	SIN15	SIN14	SIN13	SIN12	SIN11	SIN10	SIN9	SIN8
<b>R/W</b>	W	W	W	W	W	W	W	W
<b>Initial val.</b>	0	0	0	0	0	0	0	0

**[FAh : Simultaneous Press and Idle Mode Entry]**

Name: CMD  
Address: FAh

Description:

**SIMUL\_SEL : Simultaneous push judgment element choice :**

In the case of simultaneous key press a decision must be made to select the dominant channel. The chip allows for two alternative methods. Either it can be based on whichever key press was first, or the priority can be based on the highest signal level.

1 : A level of a sensor gives priority 0 : Give priority to the channel pushed earliest

**INTERMIT\_EN : Intermittent and the drive are enable. :**

Whether intermittent is driven at the idol mode is selected.

1 : Intermittent is driven. 0 : Intermittent is not driven. Initial state : Intermittent is driven.

**IDLE\_T[3:0] : non-detect time-out setting :**

This sets the time the chip takes to go from normal mode to idle mode in a period key inactivity.

Duration = system clock x  $2^{19}$  x IDLE\_T (Example of system clock 1[MHz]time : About 520[msec])

	Bit7	Bit6	Bit5	Bit4	Bit3	Bit2	Bit1	Bit0
<b>FAh</b>	SIMUL_SE L	-	-	INTERMIT_E N	IDLE_T[3]	IDLE_T[2]	IDLE_T[1]	IDLE_T[0]
<b>R/W</b>	W	-	-	W	W	W	W	W
<b>Initial val.</b>	0	-	-	1	0	1	1	1

**【FBh : Gain Setting, Filter Function】**

Name: GAIN\_FILTER

Address: FBh

Description: Gain adjustment and setting of noise filter function.

**GAIN[2:0] : gain setting :**

It uses it for the gain adjustment in eight stages. Initial adjustment value : x1

GAIN[2:0]	000	001	010	011	100	101	110	111
Adjustment value	x 1	x 4.22	x 8.4	x 16.5	x 23	x 46	x 69	x 92

**FILTER\_EN : Filter enable :**

Enables/disables setting of noise filter function

1 : enabled 0 : disabled Initial state : disabled

**DELTA[3:0] : Filter follow count setting :**

The follow count to which the noise filter function is effective is set.

	Bit7	Bit6	Bit5	Bit4	Bit3	Bit2	Bit1	Bit0
FBh	GAIN[2]	GAIN [1]	GAIN[0]	FILTER_EN	DELTA[3]	DELTA[2]	DELTA[1]	DELTA[0]
R/W	W	W	W	W	W	W	W	W
Initial val.	0	0	0	0	0	0	1	0

**【FCh : Switch OFF -> ON Threshold】**

Name: TH\_ON

Address: FCh

Description: This register provides a threshold value for determining if a sensor has transitioned from OFF to ON. This is relative value from reference value (128d). So the absolute value of threshold is 128d + ON[6:0]. It makes a threshold value between TH\_ON and TH\_OFF. TH\_ON must be bigger than TH\_OFF (TH\_ON >= TH\_OFF) Maximum threshold is 256d and minimum value is 128d.

	Bit7	Bit6	Bit5	Bit4	Bit3	Bit2	Bit1	Bit0
FCh	-	ON[6]	ON[5]	ON[4]	ON[3]	ON[2]	ON[1]	ON[0]
R/W	-	W	W	W	W	W	W	W
Initial val.	-	0	0	1	0	0	0	0

**【FDh : Switch ON -> OFF Threshold Value】**

Name: TH\_OFF

Address: FDh

Description: This register provides a threshold value for transitioning from ON to OFF. This is relative value from reference value (128d). So absolute value of threshold is 128d + OFF[6:0]. It makes a threshold value between TH\_ON and TH\_OFF. TH\_OFF must be smaller than TH\_ON (TH\_OFF <= TH\_ON) Maximum value is 256d and minimum value is 128d.

	Bit7	Bit6	Bit5	Bit4	Bit3	Bit2	Bit1	Bit0
FDh	-	OFF[6]	OFF[5]	OFF[4]	OFF[3]	OFF[2]	OFF[1]	OFF[0]
R/W	-	W	W	W	W	W	W	W
Initial val.	-	0	0	0	0	0	0	1

**【FEh : LED Port Data】**

Name: DLED

Address: FEh

Description: When LED is not linked with the sensor, it becomes a simple digital output that controls the LED. 1 : Light. 0 : Turned off.

	Bit7	Bit6	Bit5	Bit4	Bit3	Bit2	Bit1	Bit0
FEh	D7	D6	D5	D4	D3	D2	D1	D0
R/W	W	W	W	W	W	W	W	W
Initial val.	0	0	0	0	0	0	0	0

● Operation mode

This IC has a normal mode, idle mode and a shutdown mode as states of operation.

**【Normal mode】**

This is the normal operation of the device. Output pin INT="L".

**【Idle mode】**

This is the mode when the normal mode times out due to inactivity on the keys. In this mode the control interface is still alive.

\*Usually time-out is aimed at about 200msec or less.

\*Transition between normal and idle modes is automatic and without software control.

**【Shutdown mode】**

In this mode the device is completely stopped – and reset. This is achieved by making the terminal SDN L. All analog circuits and the logic circuits are stopped. The return from the shutdown mode returns by making the terminal SDN H.

\*After shut-down all registers have their default values.

● Interface and system clock selection

I/F selection with MODE [1:0] pin. System clock selection by RXD.

**【Using 2wires serial bus mode (MODE [1:0] =00b)】**

The 2wires serial bus is used for host I/F.

RXD=0 in the system clock: Built-in oscillator is used.

RXD=1 in the system clock: The clock input from CLK\_EXT is used.

● Initialization procedure

A normal power on sequence is:

- (1) Power on
- (2) Setup the registers
- (3) Write '1' to 0xEF (done register)

<sensing operation begins after auto-calibration occurs>

● Power supply turning on procedure

You should always power on DVDD at the same time as AVDD or before AVDD.

● Ordering part number

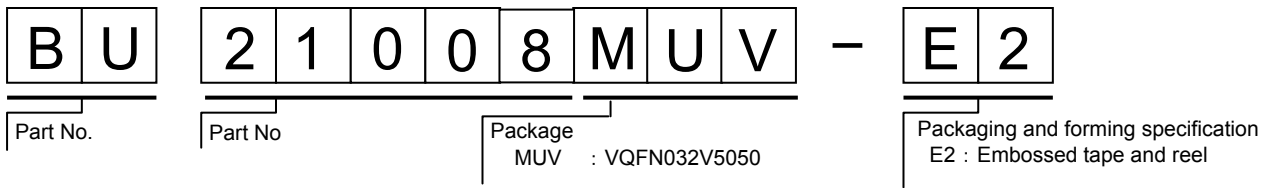

# VQFN032V5050

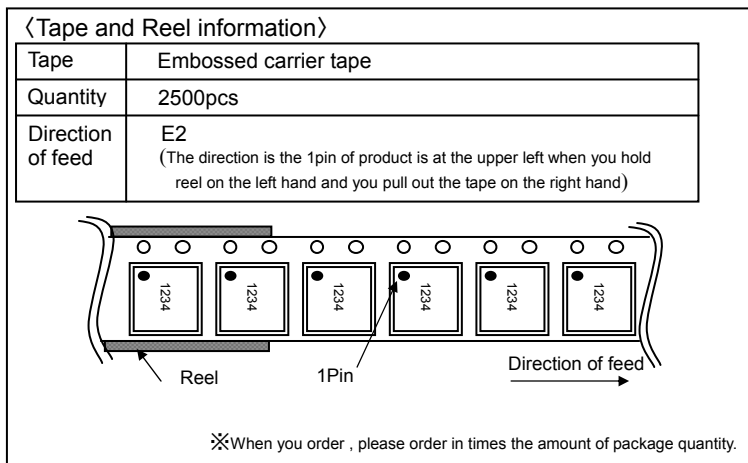
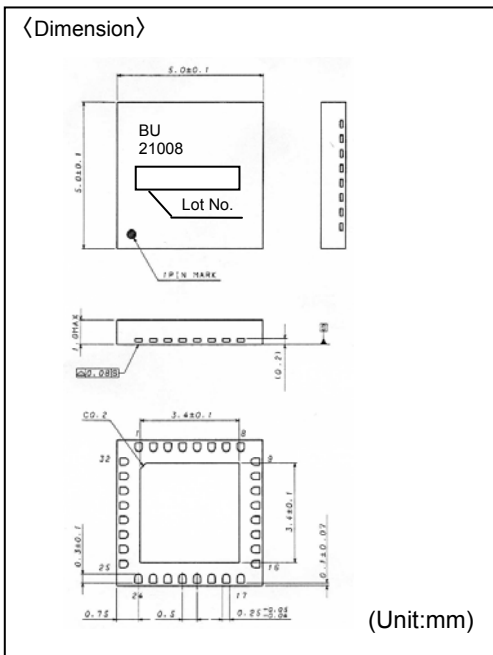

The content specified in this document is correct as of **1st , 2009, January**

No copying or reproduction of this document, in part or in whole, is permitted without the consent of ROHM CO.,LTD.

The content specified herein is subject to change for improvement without notice.

The content specified herein is for the purpose of introducing ROHM's products (hereinafter "Products"). If you wish to use any such Product, please be sure to refer to the specifications, which can be obtained from ROHM upon request.

Examples of application circuits, circuit constants and any other information contained herein illustrate the standard usage and operations of the Products. The peripheral conditions must be taken into account when designing circuits for mass production.

Great care was taken in ensuring the accuracy of the information specified in this document. However, should you incur any damage arising from any inaccuracy or misprint of such information, ROHM shall bear no responsibility for such damage.

The technical information specified herein is intended only to show the typical functions of and examples of application circuits for the Products. ROHM does not grant you, explicitly or implicitly, any license to use or exercise intellectual property or other rights held by ROHM and other parties. ROHM shall bear no responsibility whatsoever for any dispute arising from the use of such technical information.

The Products specified in this document are intended to be used with general-use electronic equipment or devices (such as audio visual equipment, office-automation equipment, communication devices, electronic appliances and amusement devices).

The Products are not designed to be radiation tolerant.

While ROHM always makes efforts to enhance the quality and reliability of its Products, a Product may fail or malfunction for a variety of reasons.

Please be sure to implement in your equipment using the Products safety measures to guard against the possibility of physical injury, fire or any other damage caused in the event of the failure of any Product, such as derating, redundancy, fire control and fail-safe designs. ROHM shall bear no responsibility whatsoever for your use of any Product outside of the prescribed scope or not in accordance with the instruction manual.

The Products are not designed or manufactured to be used with any equipment, device or system which requires an extremely high level of reliability the failure or malfunction of which may result in a direct threat to human life or create a risk of human injury (such as a medical instrument, transportation equipment, aerospace machinery, nuclear-reactor controller, fuel-controller or other safety device). ROHM shall bear no responsibility in any way for use of any of the Products for the above special purposes. If a Product is intended to be used for any such special purpose, please contact a ROHM sales representative before purchasing.

If you intend to export or ship overseas any Product or technology specified herein that may be controlled under the Foreign Exchange and the Foreign Trade Law, you will be required to obtain a license or permit under the Law.

## ROHM Sales Offices

Contact us for further information about the products.

RO128A

<b>San Diego</b> +1-858-625-3630	<b>United Kingdom</b> +44-1-908-272400	<b>Tianjin</b> +86-22-23029181	<b>Xiamen</b> +86-592-238-5705
<b>Atlanta</b> +1-770-754-5972	<b>Denmark</b> +45-3694-4739	<b>Shanghai</b> +86-21-8279-2727	<b>Zhuhai</b> +86-756-3232-480
<b>Boston</b> +1-978-371-0382	<b>Espoo</b> +358-9725-54491	<b>Hangzhou</b> +86-571-87658072	<b>Hong Kong</b> +852-2-740-6262
<b>Chicago</b> +1-847-368-1006	<b>Salo</b> +358-2-7332234	<b>Nanjing</b> +86-25-8689-0015	<b>Taipei</b> +886-2-2500-6956
<b>Dallas</b> +1-972-473-3748	<b>Oulu</b> +358-8-5372930	<b>Ningbo</b> +86-574-87654201	<b>Kaohsiung</b> +886-7-237-0881
<b>Denver</b> +1-303-708-0908	<b>Barcelona</b> +34-9375-24320	<b>Qingdao</b> +86-532-8577-9312	<b>Singapore</b> +65-6332-2322
<b>Detroit</b> +1-248-348-9920	<b>Hungary</b> +36-1-4719338	<b>Suzhou</b> +86-512-6807-1300	<b>Philippines</b> +63-2-807-6872
<b>Nashville</b> +1-615-620-6700	<b>Poland</b> +48-22-5757213	<b>Wuxi</b> +86-510-82702693	<b>Thailand</b> +66-2-254-4890
<b>Mexico</b> +52-33-3123-2001	<b>Russia</b> +7-495-739-41-74	<b>Guangzhou</b> +86-20-3878-8100	<b>Kuala Lumpur</b> +60-3-7958-8355
<b>Düsseldorf</b> +49-2154-9210	<b>Seoul</b> +82-2-8182-700	<b>Huizhou</b> +86-752-205-1054	<b>Penang</b> +60-4-2286453
<b>Munich</b> +49-8999-216168	<b>Masan</b> +82-55-240-6234	<b>Fuzhou</b> +86-591-8801-8698	<b>Kyoto</b> +81-75-365-1218
<b>Stuttgart</b> +49-711-7272-370	<b>Dalian</b> +86-411-8230-8549	<b>Dongguan</b> +86-769-8393-3320	<b>Yokohama</b> +81-45-476-2290
<b>France</b> +33-1-5697-3060	<b>Beijing</b> +86-10-8525-2483	<b>Shenzhen</b> +86-755-8307-3008	

## ROHM Co.,Ltd.

21 Saini Mizosaki-cho, Ukyo-ku,  
Kyoto 615-8585 Japan

TEL : +81-75-311-2121 FAX : +81-75-315-0172

www.rohm.com



### Notes

No copying or reproduction of this document, in part or in whole, is permitted without the consent of ROHM CO.,LTD.

The content specified herein is subject to change for improvement without notice.

The content specified herein is for the purpose of introducing ROHM's products (hereinafter "Products"). If you wish to use any such Product, please be sure to refer to the specifications, which can be obtained from ROHM upon request.

Examples of application circuits, circuit constants and any other information contained herein illustrate the standard usage and operations of the Products. The peripheral conditions must be taken into account when designing circuits for mass production.

Great care was taken in ensuring the accuracy of the information specified in this document. However, should you incur any damage arising from any inaccuracy or misprint of such information, ROHM shall bear no responsibility for such damage.

The technical information specified herein is intended only to show the typical functions of and examples of application circuits for the Products. ROHM does not grant you, explicitly or implicitly, any license to use or exercise intellectual property or other rights held by ROHM and other parties. ROHM shall bear no responsibility whatsoever for any dispute arising from the use of such technical information.

The Products specified in this document are intended to be used with general-use electronic equipment or devices (such as audio visual equipment, office-automation equipment, communication devices, electronic appliances and amusement devices).

The Products are not designed to be radiation tolerant.

While ROHM always makes efforts to enhance the quality and reliability of its Products, a Product may fail or malfunction for a variety of reasons.

Please be sure to implement in your equipment using the Products safety measures to guard against the possibility of physical injury, fire or any other damage caused in the event of the failure of any Product, such as derating, redundancy, fire control and fail-safe designs. ROHM shall bear no responsibility whatsoever for your use of any Product outside of the prescribed scope or not in accordance with the instruction manual.

The Products are not designed or manufactured to be used with any equipment, device or system which requires an extremely high level of reliability the failure or malfunction of which may result in a direct threat to human life or create a risk of human injury (such as a medical instrument, transportation equipment, aerospace machinery, nuclear-reactor controller, fuel-controller or other safety device). ROHM shall bear no responsibility in any way for use of any of the Products for the above special purposes. If a Product is intended to be used for any such special purpose, please contact a ROHM sales representative before purchasing.

If you intend to export or ship overseas any Product or technology specified herein that may be controlled under the Foreign Exchange and the Foreign Trade Law, you will be required to obtain a license or permit under the Law.

Thank you for your accessing to ROHM product informations.

More detail product informations and catalogs are available, please contact your nearest sales office.

**ROHM Customer Support System**

**THE AMERICAS / EUROPE / ASIA / JAPAN**

[www.rohm.com](http://www.rohm.com)

Contact us : [webmaster@rohm.co.jp](mailto:webmaster@rohm.co.jp)