

## System Power Supply for TV Series

# FET Controller Type 3ch System Power Supply ICs

**BD8628EFV, BD8624EFV**

No.09034EAT06

**●Description**

BD8628EFV / BD8624EFV have realized the high performance and reliability required as a power supply for thin-screen TV.

With built-in FET 1ch current mode control, the DC/DC Converter series has the advantage of high-speed load response and wide phase margin.

Due to the high-speed load response, it is most suitable for TV-purpose processors with increasingly high performance, and due to the wide phase margin it leaves a good margin for board pattern & constant setting and so facilitates its application design.

As a high-reliability design, it has various built-in protection circuits (overcurrent protection, output voltage abnormal protection, thermal protection, and off-latch function at the time of abnormality etc.), therefore as an advantage it does not easily damage in every possible abnormal condition such as all-pin short circuit test etc. and hence most suitable for thin-screen TV which requires the high reliability.

**●Features**

- 1) 11ch synchronous rectification step-down system DC/DC converter
- 2) Soft start, soft off function
- 3) Built-in low voltage / overvoltage protection function
- 4) Built-in overcurrent protection function
- 5) Frequency setting by external resistance is available. (RT terminal)
- 6) Protection time setting by external resistance is available. (RSET terminal)
- 7) Built-in RT / RSET terminal open/short protection function
- 8) Protection control with built-in sequencer
- 9) Built-in adjustment function time of off latch
- 10) Built-in error state detection signal output function
- 11) Built-in tracking function
- 12) Corresponded to protecting bus
- 13) Load current Maximum 3A
- 14) HTSSOP-B24 Package

## ●Electric characteristic

(Ta=25°C, VCC=6.5V, GND=0V, CTL=6.5V unless otherwise specified.)

Parameter	Symbol	specification value			UNIT	Condition
		MIN	TYP	MAX		
Circuit current 1	I <sub>Q1</sub>	-	0	10	μA	CTL=0V
Circuit current 2	I <sub>Q2</sub>	-	3.4	-	mA	CTL=VCC
< Error amplifier part >						
Standard voltage (VREF)	V <sub>REF</sub>	0.792	0.8	0.808	V	Terminal FB and FC terminal short
Terminal FB Input bias current	I <sub>FB</sub>	-1	0	1	μA	V <sub>FB</sub> =0.9V
Terminal FC Clamping voltage H	V <sub>FCH</sub>	1.8	-	-	V	V <sub>FB</sub> =0.7V
Terminal FC Clamping voltage L	V <sub>FCL</sub>	-	-	0.2	V	V <sub>FB</sub> =0.9V
Terminal FC Sink current	I <sub>FC</sub> SINK	0.5	-	-	mA	V <sub>FB</sub> =0.9V, V <sub>FC</sub> =0.4V
Terminal FC Source current	I <sub>FC</sub> SOURCE	-	-	-70	μA	V <sub>FB</sub> =0.7V, V <sub>FC</sub> =1.6V
Open loop gain	A <sub>VERR</sub>	-	100	-	dB	
<OSC part>						
Oscillation frequency	F <sub>OSC</sub>	400	500	600	kHz	When terminal RT 27kΩ is connected
<Soft start >						
Charging current	I <sub>SS</sub>	-3	-2.5	-2	μA	V <sub>SS</sub> =1.0V
Terminal SS Threshold voltage	V <sub>SSTH</sub>	0.98	1.08	1.18	V	V <sub>SS</sub> Voltage
Terminal SS Clamping voltage	V <sub>SSCLM</sub>	2.2	2.4	-	V	
Terminal SS Standby voltage	V <sub>SSSTB</sub>	0.1	0.15	-	V	V <sub>SS</sub> Voltage (L to H)
Terminal SS Discharge resistance	R <sub>SS</sub>	49	70	91	kΩ	CTL=0V
Terminal SS Protection circuit start voltage	V <sub>SSPON</sub>	1.0	1.1	1.2	V	V <sub>SS</sub> Voltage (L to H)
Terminal SS Protection circuit start voltage Maximum hysteresis error	V <sub>SSPON_HYS</sub>	10	100	200	mV	V <sub>SS</sub> Voltage
< Low voltage, over voltage detection part>						
Terminal FB Low voltage detection voltage	V <sub>LVP</sub>	0.51	0.56	0.61	V	V <sub>FB</sub> Voltage
Terminal FB Overvoltage detection voltage	V <sub>OV</sub>	0.86	0.96	1.06	V	V <sub>FB</sub> Voltage
< Over current detection part>						
Output current limitation threshold	I <sub>lim</sub>	VCC-0.9	VCC-0.7	VCC-0.5	V	V <sub>SW</sub> Voltage
<Power MOS>						
Upper side MOS ON resistance	R <sub>ONU</sub>	-	110	-	mΩ	V <sub>BOOT</sub> -V <sub>SW</sub> =5V
Lower side MOS ON resistance	R <sub>ONL</sub>	-	110	-	mΩ	V <sub>VREG5</sub> =5V
<Others>						
Terminal PDET L output voltage	V <sub>OL_PDET</sub>	-	-	0.4	V	I <sub>OL</sub> =100μA
Terminal CTL input voltage H level voltage	V <sub>IH_CTL</sub>	2.0	-	VCC	V	CTL terminal
Terminal CTL input voltage L level voltage	V <sub>IL_CTL</sub>	-	-	0.5	V	CTL terminal
Terminal CTL input current	I <sub>I_CTL</sub>	-	60	90	μA	CTL terminal, CTL=VCC

V<sub>FB</sub> : FB terminal voltage, V<sub>FC</sub> : FC terminal voltage, V<sub>SS</sub> : SS terminal voltage, V<sub>MONVCC</sub> : MONVCC terminal voltage

Not designed for radiation resistance.

Current capability should not exceed Pd.

Permissible loss

This package is a product of which the feature is the high heat radiation, and connect the back to GND based on recommended land pattern when you mount.

$\theta_{jc}$ [°C /W]	$\theta_{ja}$ [°C /W]	$T_{STGmin}$ [°C]	$T_{STGmax}$ [°C]	$T_{a min}$ [°C]	$T_{a max}$ [°C]	$T_{cmax}$ Destruction temperature [°C]	$T_{jmax}$ Destruction temperature [°C]
19.0	31.3	-50.0	150.0	-45.0	85.0	150.0	150.0

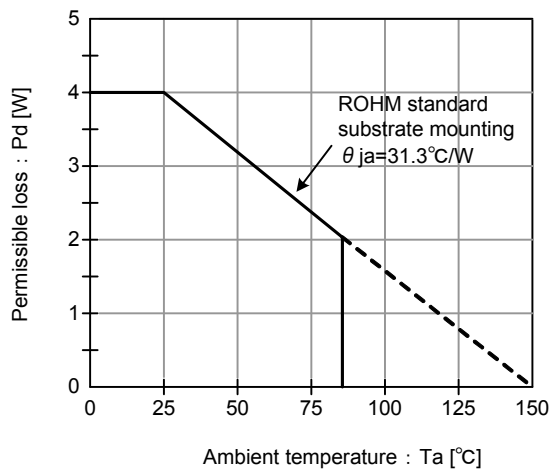

ROHM standard substrate specification  
 Material 4 layer glass epoxy substrate(back copper foil70mm x 70mm)  
 Size 70mm x 70mm x 1.6mmt(Sarmalbiaing is in the substrate.)

**Figure.1 Heat decrease curve**

※These values are the actual measurement values, and no guarantee values.

●Block diagram

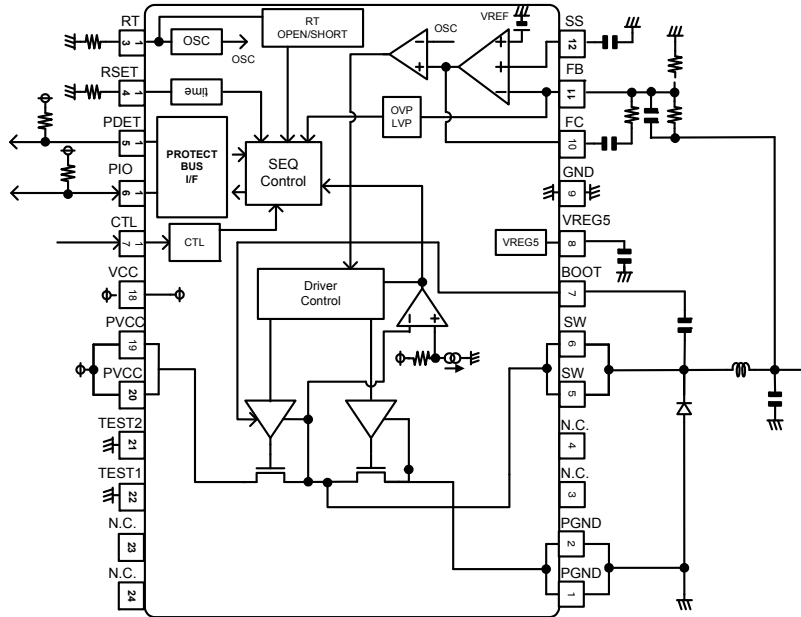

Figure.2 Block diagram, Application diagram

●Terminal explanation

Table 1 Terminal explanation

No.	Symbol	Description	No.	Symbol	Description
1	PGND	Power GND terminal	13	RT	Frequency adjustment resistance connection terminal
2	PGND	Power GND terminal	14	RSET	Off latch effective time adjustment resistance terminal
3	N.C.	No wire connection. (Connect to GND.)	15	PDET	Error state notification terminal
4	N.C.	No wire connection. (Connect to GND.)	16	PIO	Error state notification and external IC error detection terminal
5	SW	SW terminal	17	CTL	Enable input
6	SW	SW terminal	18	VCC	VCC power supply terminal
7	BOOT	High side Power MOS gate drive power source terminal	19	PVCC	Power VCC terminal
8	VREG5	Internal power supply (5.0V) output terminal	20	PVCC	Power VCC terminal
9	GND	GND	21	TEST2	Test terminal (Connect to GND.)
10	FC	Phase amends terminal	22	TEST1	Test terminal (Connect to GND.)
11	FB	Feedback terminal	23	N.C.	No wire connection. (Connect to GND.)
12	SS	Soft start adjustment capacity connection terminal	24	N.C.	No wire connection. (Connect to GND.)

※Please give to VCC+0.3V as an operation condition in all input terminals except the terminal BOOT. However, please do not exceed the absolute maximum rating as VCC=PVCC.

● Terminal equivalent circuit chart

Terminal No.	Terminal name	Explanation	Terminal equivalent circuit chart
1	PGND	Power GND (The same potential as the GND terminal)	
2	PGND	Power GND (The same potential as the GND terminal)	
5	SW	SW terminal	
6	SW	SW terminal	
7	BOOT	High side Power MOS gate drive power source terminal	
8	VREG5	Internal power supply (5.0V) output terminal	
9	GND	GND	
10	FC	Phase amends terminal	

Terminal No.	Terminal name	Explanation	Terminal equivalent circuit chart
11	FB	Voltage detection terminal	
12	SS	Soft start adjustment capacity connection terminal	
13	RT	Frequency adjustment resistance connection terminal	
14	RSET	Off latch effective time adjustment resistance terminal	
15	PDET	Error state notification terminal	

Terminal No.	Terminal name	Explanation	Terminal equivalent circuit chart
16	PIO	Error state notification and external IC error detection terminal	
17	CTL	Enable input	
21	TEST2	Test terminal (Connect to GND. )	
22	TEST1	Test terminal (Connect to GND. )	
19	PVCC	Power VCC terminal	
20	PVCC	Power VCC terminal	

●Operation description

ON/OFF control

DC/DC converter ON/OFF function

DC/DC converter controller can be controlled ON/OFF by CTL terminal.

Analog circuit starts operation at ON control (on mode), and goes down to setting output voltage.

Analog circuit should be standby at OFF control (off mode), and output voltage becomes 0V.

Table2 DC/DC converter ON/OFF function

CTL terminal voltage	
>VIHCTL	ON control
<VILCTL	OFF control

Soft start time set function

DC/DC converter can do soft start without overshoot by charging soft start capacity (C<sub>SS</sub>) connected between SS terminal and GND by charging current at ON control.

The mute of the output is released when it reaches V<sub>SS</sub>=0.15V (V<sub>SSSTB</sub>), and the output voltage does the soft start operation from the point of V<sub>SS</sub>=0.3V (typ) in proportion to the voltage of the terminal SS.

Also, soft start time (t<sub>SS</sub>) can be set by setting soft start capacity arbitrarily.

Soft start time (t<sub>SS</sub>) should be set at 3msec < t<sub>SS</sub> < 30msec.

※Please note that the overshoot is not caused in the output setting voltage when setting it to t<sub>SS</sub> ≤ 3msec.

$$t_{SS} = \frac{V_{SSTH} \times C_{SS}}{I_{SS}}$$

Discharge function

DC/DC converter can do soft off by discharging load discharged to soft start capacity connected between SS terminal to GND by discharging resistance at OFF control.

Soft off operates in proportion to the voltage of the terminal SS the output voltage from the point of V<sub>SS</sub>=0.8V (typ).

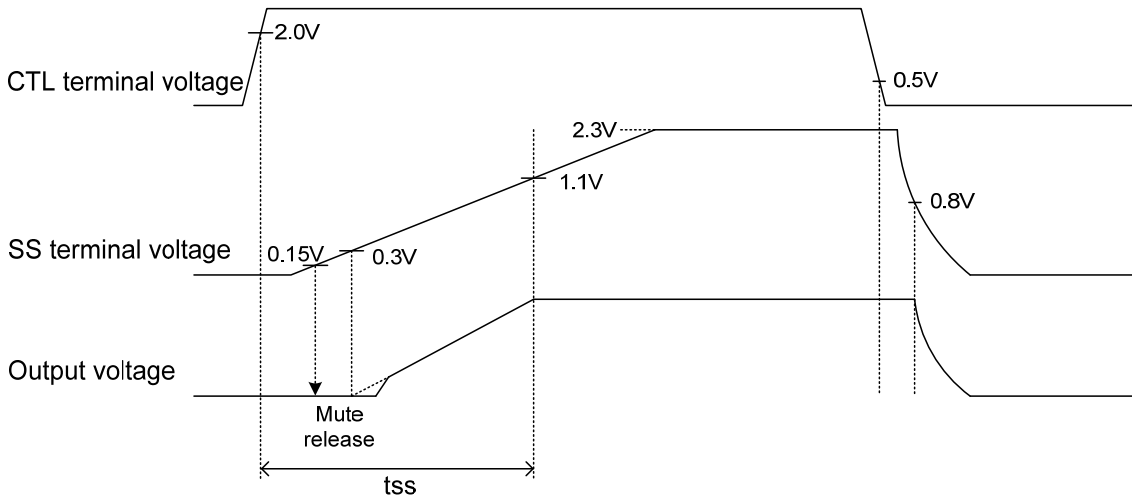
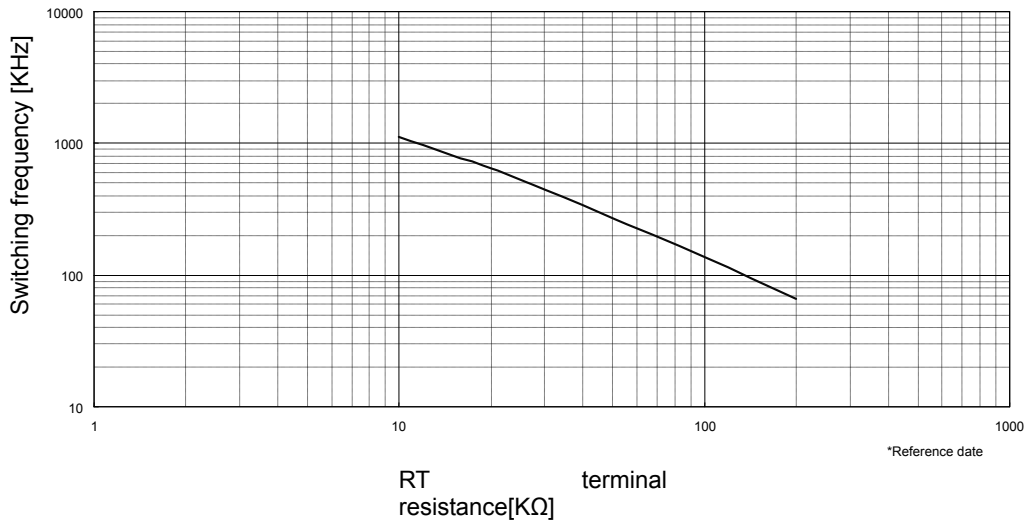

Figure.3 Wave form at ON/OFF control

OSC oscillation frequency setting function

SW output oscillation frequency of DC/DC converter can be set by installing resistance between RT terminal and GND externally.



**Figure.4 Terminal RT resistance-oscillation frequency**

Range of terminal RT connection resistance setting

$$23\text{k}\Omega \leq R_{rt} \leq 135\text{k}\Omega$$

$$(100\text{kHz} \leq f_{osc} \leq 600\text{kHz})$$

PROTECT BUS Input/output function

The terminal PIO is PROTECT BUS Input/output terminal. The terminal PIO is Hi-Z when DC/DC usually operates. When the terminal PIO becomes LOW by connecting PROTECT BUS, DC/DC is turned off. Afterwards, when the terminal PIO becomes HIGH, it reactivates.

DC/DC is Off latch when DC/DC error detects it and the terminal PDET becomes LOW.

**Table3 PIO terminal, PDET terminal output function**

DC/DC Error detection	PIO terminal	PDET terminal	DC/DC
Undetection	Hi-Z	Hi-Z	ON
Undetection	LOW	Hi-Z	OFF
Detection	LOW	LOW	Off latch

**PROTECT BUS Timing chart**

If two or more BD8628EFV//BD8624FV is connected in PROTECT BUS, and it uses at the same time, when one IC error detects, all remaining IC becomes PIO = Low at the same time, and the output is turned off.

**Protecting BUS part timing chart**

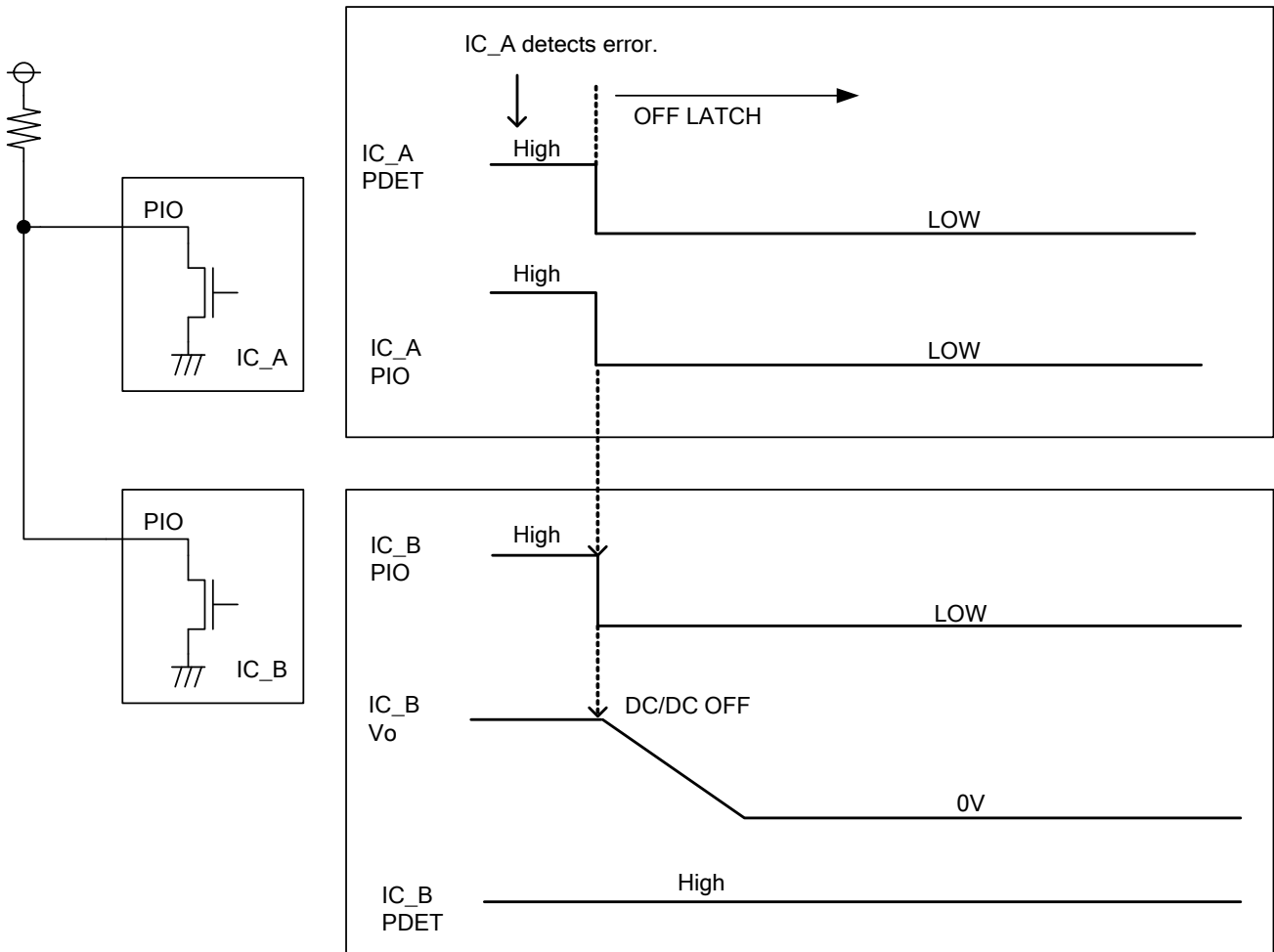

When two or more BD8628EFV//BD8624FV is used at the same time, If one IC error detects, all IC becomes DC/DC OFF at the same time.

●Protection function

Protection circuit is effective for destruction prevention due to accident so that avoid using by continuous protection operation.

Low voltage protection function(LVP)

Low voltage protection function detects set output voltage VO from FB terminal and off-latched DC/DC converter compared to internal reference level.

Low voltage protection function operates when FB terminal voltage falls below VLVP (=0.7 x VREF) and continues more than set time in external resistance.

**Table 4 Low voltage protection function**

CTL terminal	SS terminal	FB terminal	Low voltage protection function	Low voltage protection operation
>VIHCTL	>1.1V(typ)	<VLVP	Enable	ON
		>VLVP+VLVP_HYS		OFF
	<1.0V(typ)	-	Disable	OFF
<VILCTL	-	-	Disable	OFF

※Constant voltage protection function is enabled when SS terminal voltage becomes more than 1.1V (typ) in the transition to ON control (during soft start).

Overvoltage protection function (OVP)

Overvoltage protection function detects set output voltage VO from FB terminal and off-latched DC/DC converter controller compared to internal reference level.

Overvoltage protection function operates when FB terminal voltage exceeds VOVP (=1.2 x VREF) and continues more than set time in external resistance.

**Table 5 Overvoltage protection function**

CTL terminal	SS terminal	FB terminal	Overvoltage protection function	Overvoltage protection operation
>VIHCTL	>1.1V(typ)	>VOVP	Enable	ON
		<VOVP		OFF
	<1.0V(typ)	-	Disable	OFF
<VILCTL	-	-	Disable	OFF

※Overvoltage protection function is enabled when SS terminal voltage of each Ch becomes more than 1.1V (typ) in the transition to ON control (during soft start).

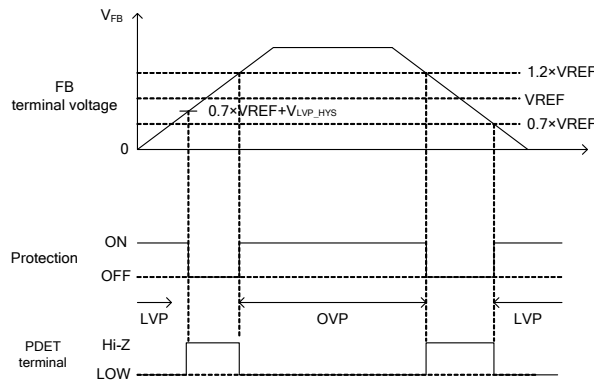

**Figure.5 Low voltage / overvoltage protection**

Overcurrent protection function (OCP)

Overcurrent protection function compared drain voltage (LX terminal voltage) with internal OCP terminal voltage when internal Nch POWER MOS is ON. When LX terminal voltage becomes lower than OCP terminal voltage, external MOS would be OFF.

Off latch by overcurrent protection function operates when LX terminal voltage falls below OCP terminal voltage and continues more than set time in external resistance.

**Table 6 overcurrent protection function**

CTL terminal	SS terminal	Output current	Overcurrent protection function	Overcurrent protection operation
>VIHCTL	>1.1V(typ)	>I <sub>lmt</sub>	Enable	ON
		<I <sub>lmt</sub>		OFF
	<1.0V(typ)	-	Disable	OFF
<VILCTL	-	-	Disable	OFF

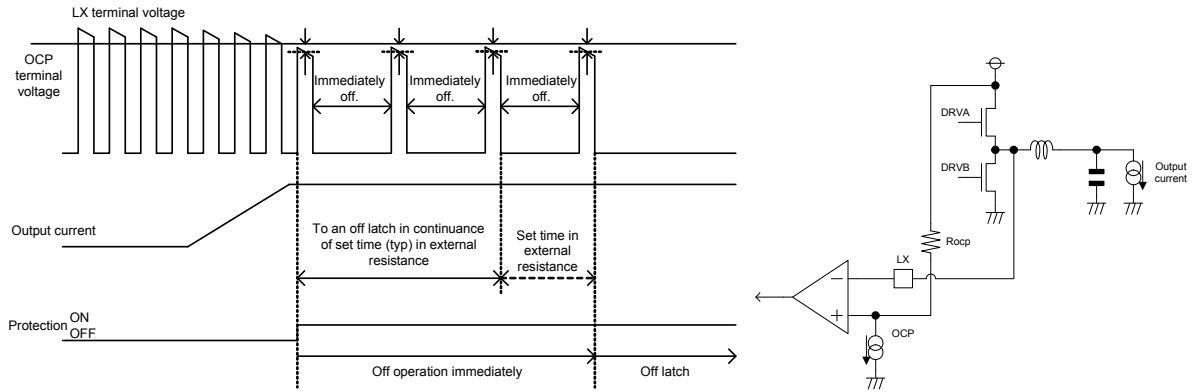

**Figure.6 Overcurrent protection**

RT terminal open/short protection function

RT terminal open/short protection function off-latches all DC/DC converter controller by detecting open/short condition internally from RT terminal to prevent from output voltage error caused by error oscillation of internal triangular wave at RT terminal open/short.

RT terminal open/short protection function is regularly enabled after boot-up.

RT terminal open/short protection function operates when error detection condition continues more than set time in external resistance.

Soft start time-out function

DC/DC converter off-latch-controls when  $V_{SS}$  does not exceed  $V_{SSPON}$  from  $V_{SS} > V_{SSSTB} + V_{SSSTB\_HYS}$  after 50msec (typ) passed from soft start.

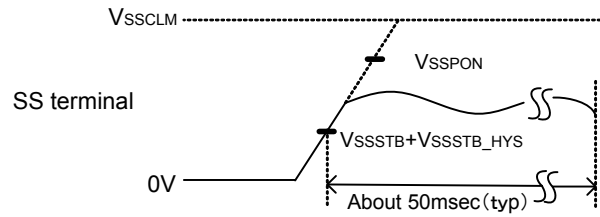

**Figure.7 At soft start time-out**

Error detection (off latch) release method

DC/DC converter becomes off latch condition when protection function operates. Off latch can be released by the following method. DC/DC converter controller of each Ch becomes able to do ON control transition by releasing off latch.

1. Set all Ch CTL terminal voltage as  $< V_{ILCTL}$  and continue that condition about more than 200usec (typ).
2. Drop down power supply VCC to below 2.7V(TYP).

Error detection time set function

Time from the error detection to the off latch can be set by putting resistance outside between GND and RSET terminal.

$$t_{\text{offlatch}} = 1.8 \times 10^{-3} \times R_{\text{rset}} \quad [\text{usec}]$$

Rset setting range

$$10\text{k}\Omega \leq R_{\text{set}} \leq 75\text{k}\Omega$$

$$(18\text{usec} \leq t_{\text{offlatch}} \leq 135\text{usec})$$

●Ordering part number

B	D
---	---

Part No

8	6	2	8
---	---	---	---

Part No.  
8628  
8624

E	F	V
---	---	---

Package  
EFV: HTSSOP-B24

E	2
---	---

Packaging and forming specification  
E2: Embossed tape and reel

HTSSOP-B24

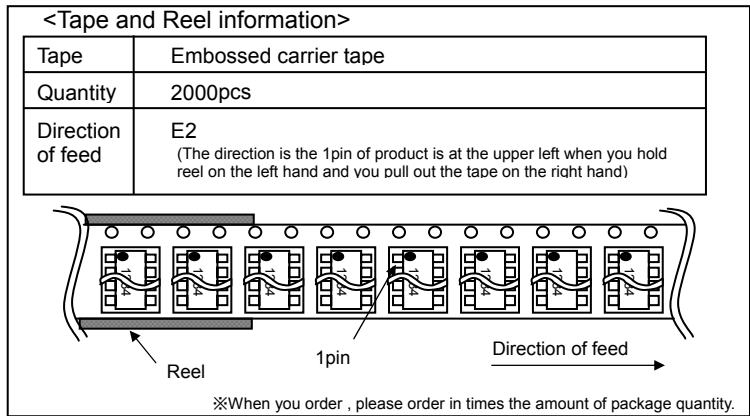
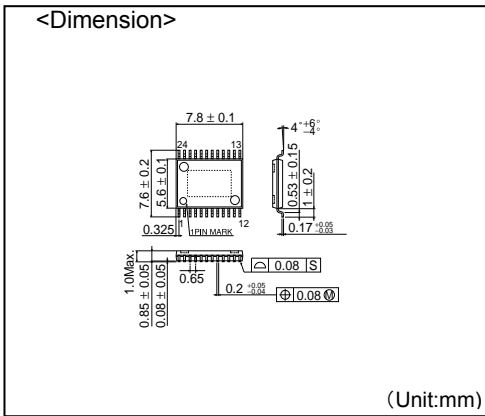

## Notes

No copying or reproduction of this document, in part or in whole, is permitted without the consent of ROHM Co.,Ltd.

The content specified herein is subject to change for improvement without notice.

The content specified herein is for the purpose of introducing ROHM's products (hereinafter "Products"). If you wish to use any such Product, please be sure to refer to the specifications, which can be obtained from ROHM upon request.

Examples of application circuits, circuit constants and any other information contained herein illustrate the standard usage and operations of the Products. The peripheral conditions must be taken into account when designing circuits for mass production.

Great care was taken in ensuring the accuracy of the information specified in this document. However, should you incur any damage arising from any inaccuracy or misprint of such information, ROHM shall bear no responsibility for such damage.

The technical information specified herein is intended only to show the typical functions of and examples of application circuits for the Products. ROHM does not grant you, explicitly or implicitly, any license to use or exercise intellectual property or other rights held by ROHM and other parties. ROHM shall bear no responsibility whatsoever for any dispute arising from the use of such technical information.

The Products specified in this document are intended to be used with general-use electronic equipment or devices (such as audio visual equipment, office-automation equipment, communication devices, electronic appliances and amusement devices).

The Products specified in this document are not designed to be radiation tolerant.

While ROHM always makes efforts to enhance the quality and reliability of its Products, a Product may fail or malfunction for a variety of reasons.

Please be sure to implement in your equipment using the Products safety measures to guard against the possibility of physical injury, fire or any other damage caused in the event of the failure of any Product, such as derating, redundancy, fire control and fail-safe designs. ROHM shall bear no responsibility whatsoever for your use of any Product outside of the prescribed scope or not in accordance with the instruction manual.

The Products are not designed or manufactured to be used with any equipment, device or system which requires an extremely high level of reliability the failure or malfunction of which may result in a direct threat to human life or create a risk of human injury (such as a medical instrument, transportation equipment, aerospace machinery, nuclear-reactor controller, fuel-controller or other safety device). ROHM shall bear no responsibility in any way for use of any of the Products for the above special purposes. If a Product is intended to be used for any such special purpose, please contact a ROHM sales representative before purchasing.

If you intend to export or ship overseas any Product or technology specified herein that may be controlled under the Foreign Exchange and the Foreign Trade Law, you will be required to obtain a license or permit under the Law.



Thank you for your accessing to ROHM product informations.  
More detail product informations and catalogs are available, please contact us.

## ROHM Customer Support System

<http://www.rohm.com/contact/>