

System Motor Driver ICs for CD / DVD / Blu-ray Drive and Recorder

# System Motor Driver IC for Half Height Drive (3 Sensors)



BD7959EFV

No.10012EAT02

## ●Description

BD7959EFV are ICs, developed for the spindle motor, actuator coil, tilt coil, stepping motor, SA (Spherical Aberration) motor and the loading motor drive of the Blu-ray Drive. The spindle, stepping and SA motor driver use power MOSFET to reduce power consumption and the actuator, tilt, and loading driver use a linear BTL drive system to reduce noise.

## ●Features

- 1) Correspondence to the Blu-ray drive control with built-in 9ch.
- 2) The spindle motor driver achieves low noise by ROHM's own energizing method.
- 3) Highly effective spindle, stepping and SA driver is achieved by PWM control driver. And the output current detection resistance of stepping and SA driver is unnecessary by built-in internal detection circuit.
- 4) The actuator, tilt and loading driver achieve low noise by using linear BTL drive system.
- 5) ON/OFF of loading and other channels, brake mode of spindle driver and standby mode are selectable by the two control terminals.
- 6) Built-in thermal-shut down circuit.
- 7) Built-in triangular wave generator.
- 8) Improved heat radiation efficiency utilizing HTSSOP package.

## ●Applications

Optical disk equipment, such as Blu-ray recorders

## ●Absolute maximum ratings

Parameter	Symbol	Ratings	Unit
POWER MOS power supply voltage	SPVM,SL/SAVM	15 #1	V
Preblock/BTL power block power supply voltage	Vcc,AVM	15	V
PWM control block power supply voltage	DVcc	7	V
Pick-up pull charge capacitor terminal voltage	CHG_C	15	V
Power dissipation	Pd	2.0 #2	W
Operating temperature range	Topr	-20 ~ 75	°C
Storage temperature	Tstg	-55 ~ 150	°C
Joint part temperature	Tjmax	150	°C

#1 POWER MOS output terminals (35~42pin, 45 ~ 47pin) are contained.

#2 PCB mounting (70mmX70mmX1.6mm, occupied copper foil is less than 3%, glass epoxy standard board).  
Reduce by 16mW/°C over 25°C

●Recommended operating conditions

(Set the power supply voltage with consideration to power dissipation)

Parameter	Symbol	Ratings			Unit
		Min.	Typ.	Max.	
Spindle driver powerblock power supply voltage	SPVM	—	V <sub>cc</sub> <sup>#3</sup>	—	V
Sled / SA motor driver powerblock power supply voltage	SL/SAVM	—	V <sub>cc</sub> <sup>#3</sup>	—	V
Preblock / Loading driver power supply voltage	V <sub>cc</sub>	10.8	12	13.2	V
Actuator driver power block power supply voltage	AVM	4.3	5.0	5.5	V
PWM control block power supply voltage	DV <sub>cc</sub>	4.3	5.0	5.5	V
Spindle driver output current	I <sub>osp</sub>	—	1.2	2.5 <sup>#4</sup>	A
Actuator, sled/SA motor, loading motor driver output current	I <sub>oo</sub>	—	0.5	0.8	A

#3 Set the same supply voltage to SPVM, SLVM and V<sub>cc</sub>.

#4 The current is guaranteed 3.0A in case of the Short-circuit braking mode and the current which is turned on/off in a duty-ratio of less than 1/10 with a maximum on-time of 5msec.

### ●Electrical characteristics

(Unless otherwise noted, Ta=25°C, Vcc=SL/SAVM=12V, DVcc=AVM=5V, SPRNF=0.33 Ω, RL=8 Ω, RLSP=2 Ω, PICKCTL=3.3V)

Parameter	Symbol	Limits			Unit	Condition
		MIN.	TYP.	MAX.		
<b>Circuit current</b>						
Quiescent current 1	IQ1	—	12	24	mA	Vcc (Loading OFF)
Quiescent current 2	IQ2	—	7	12	mA	Vcc (Loading ON)
Quiescent current 3	IQ3	—	7	12	mA	DVcc
Standby-on current 1	IST1	—	—	0.5	mA	Vcc
Standby-on current 2	IST2	—	—	1.0	mA	DVcc
<b>Sled driver block</b>						
Input dead zone (one side)	VDZSL	0	20	80	mV	
Input output gain	gmSL	1.0	1.25	1.5	A/V	RIN1,2=62k Ω
Output On resistor (top and bottom)	RONSL	—	2.2	3.3	Ω	IL=500mA
Output limit current	ILIMSL	0.84	1.2	1.56	A	
PWM frequency	fosc	—	100	—	kHz	
<b>SA driver block</b>						
Input dead zone (one side)	VDZSA	0	60	120	mV	
Input output gain	gmSA	0.141	0.17	0.199	A/V	RIN1=68k Ω, RIN2=75k Ω
Output On resistor (top and bottom)	RONSA	—	2.2	3.3	Ω	IL=200mA
Output limit current	ILIMSA	280	400	520	mA	
PWM frequency	fosc	—	100	—	kHz	
<b>Spindle driver block</b>						
Input dead zone (one side)	VDZSP	0	10	40	mV	
Input output gain	gmSP	0.91	1.15	1.39	A/V	SPRNF=0.33 Ω
Output On resistor (top and bottom)	RONSP	—	1.5	2.6	Ω	IL=500mA
Output limit current	ILIMSP	0.88	1.1	1.32	A	SPRNF=0.33 Ω
PWM frequency	fosc	—	100	—	kHz	
<b>Actuator driver block</b>						
Output offset voltage	VOFFT	-50	0	50	mV	
Output saturation voltage	VOFT	—	0.9	1.8	V	IL=500mA
Voltage gain	GVFT	15.5	17.5	19.5	dB	
<b>Loading driver block</b>						
Output offset voltage	VOFLD	-50	0	50	mV	
Output saturation voltage	VOLD	—	2.2	2.9	V	IL=500mA
Voltage gain	GVLD	15.5	17.5	19.5	dB	
<b>CTL1,CTL2, PickCTL terminal</b>						
Input high voltage	VCTLH	2.0	—	3.7	V	
Input low voltage	VCTLL	GND	—	0.5	V	
<b>Others</b>						
VC drop-muting	VMVC	0.4	0.7	1.0	V	
Vcc drop-muting	VMVcc	3.4	3.8	4.2	V	

\*This product is not designed to be radiation-resistant.

●Block diagram

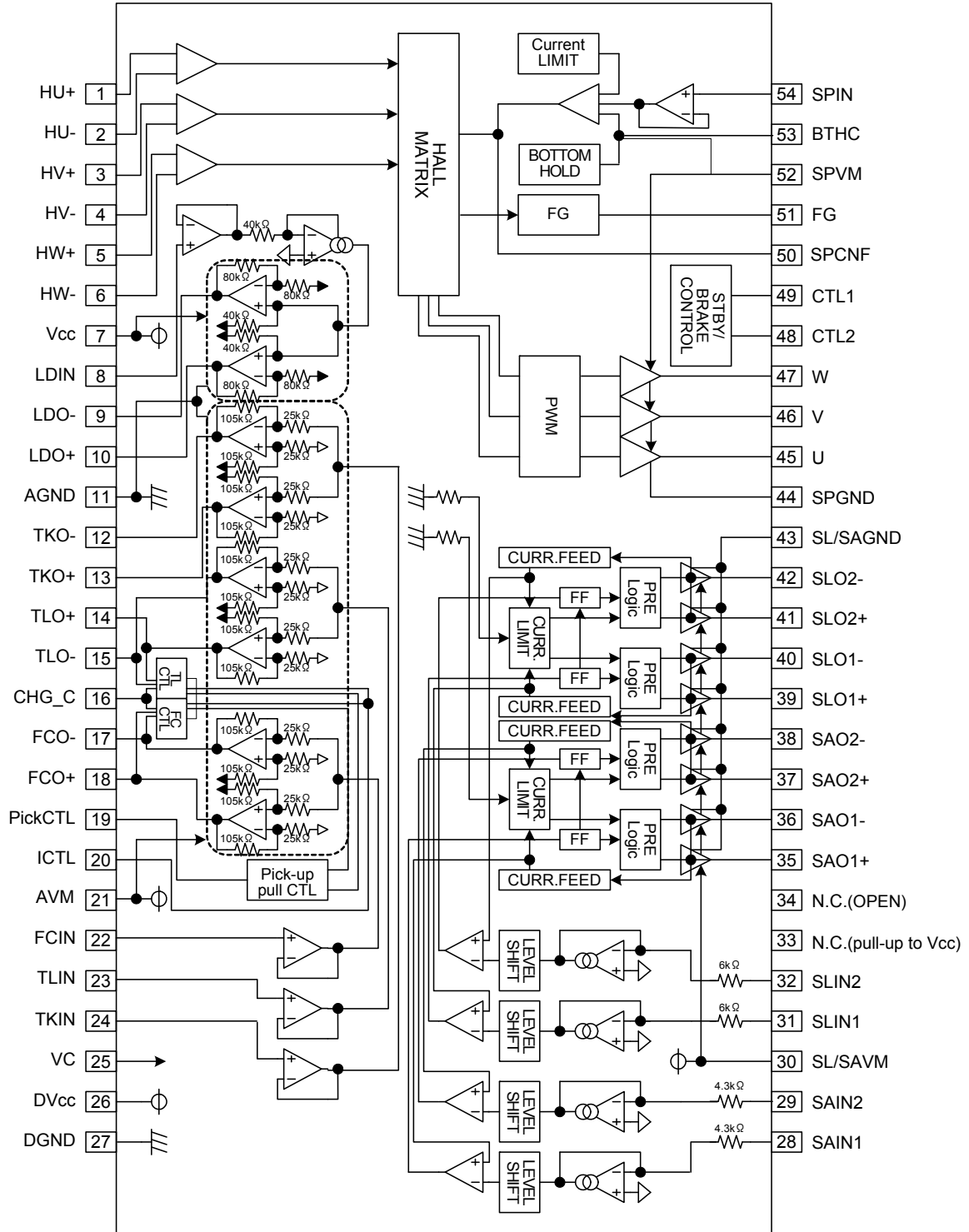

## ●Pin description

No.	Symbol	Description	No.	Symbol	Description
1	HU+	Hall amp U positive input	28	SAIN1	SA driver 1 input
2	HU-	Hall amp U negative input	29	SAIN2	SA driver 2 input
3	HV+	Hall amp V positive input	30	SL/SAVM	Sled / SA driver pre and power supply
4	HV-	Hall amp V negative input	31	SLIN1	Sled driver1 input
5	HW+	Hall amp W positive input	32	SLIN2	Sled driver2 input
6	HW-	Hall amp W negative input	33	N.C.	N.C. (pull-up to Vcc)
7	Vcc	BTL pre and Loading power supply	34	N.C.	N.C. (OPEN)
8	LDIN	Loading driver input	35	SAO1+	SA driver1 positive output
9	LDO-	Loading driver negative output	36	SAO1-	SA driver1 negative output
10	LDO+	Loading driver positive output	37	SAO2+	SA driver2 positive output
11	AGND	BTL driver block power ground	38	SAO2-	SA driver1 negative output
12	TKO-	Tracking driver negative output	39	SLO1+	Sled driver1 positive output
13	TKO+	Tracking driver positive output	40	SLO1-	Sled driver1 negative output
14	TLO+	Tilt driver positive output	41	SLO2+	Sled driver2 positive output
15	TLO-	Tilt driver negative output	42	SLO2-	Sled driver2 negative output
16	CHG_C	Pick-up pull charge capacitor terminal	43	SL/SAGND	Sled/SA driver block pre and power ground
17	FCO-	Focus driver negative output	44	SPGND	Spindle driver power ground
18	FCO+	Focus driver positive output	45	U	Spindle driver output U
19	Pick CTL	Pick-up pull control terminal	46	V	Spindle driver output V
20	ICTL	Pick-up pull current control terminal	47	W	Spindle driver output W
21	AVM	Actuator driver block power supply	48	CTL2	Driver logic control 2 input
22	FCIN	Focus driver input	49	CTL1	Driver logic control 1 input
23	TLIN	Tilt driver input	50	SPCNF	Spindle driver feedback filter
24	TKIN	Tracking driver input	51	FG	Frequency generator output
25	VC	Reference voltage input	52	SPVM	Spindle driver power supply
26	DVcc	PWM block control power supply	53	BTHC	Capacitor connection terminal for spindle current bottom holding
27	DGND	Pre-ground	54	SPIN	Spindle driver input

\*Positive/negative of the output terminals is determined in reference to those of the input terminals.

●Equivalent-circuit diagram of the terminals

<p>Spindle Driver output</p>	<p>Spindle driver current detection input</p>	<p>Spindle driver error amplifier input pin</p>
<p>Hall signal input</p>	<p>FG signal input</p>	<p>Spindle driver input</p>
<p>Spindle driver feedback filter pin</p>	<p>PWM driver output(SLED1,2 SA1,2)</p>	<p>PWM driver input(SLED1,2)</p>
<p>PWM driver input (SA1,2)</p>	<p>BTL driver output(FC,TK,TL)</p>	<p>BTL driver output(LD)</p>

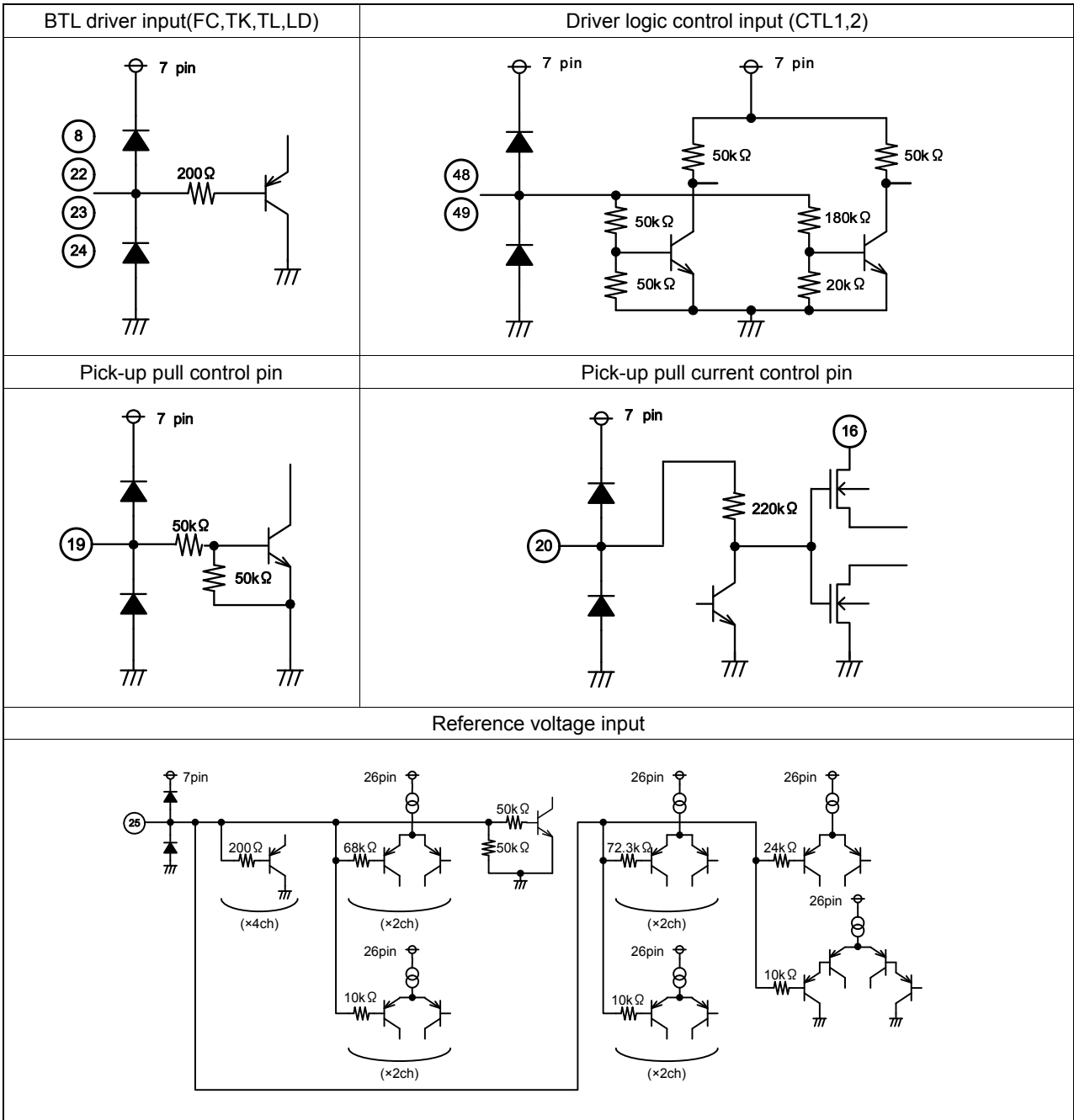

● Test circuit

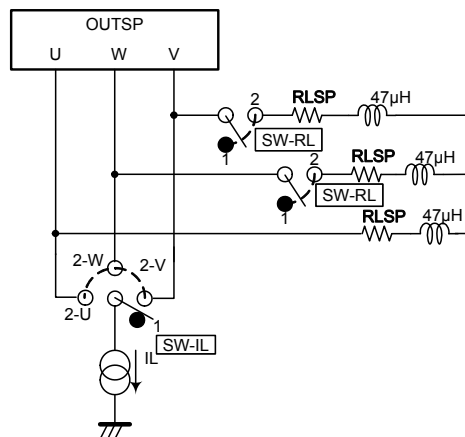
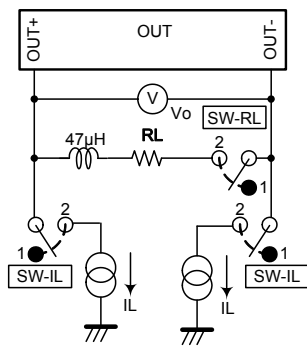
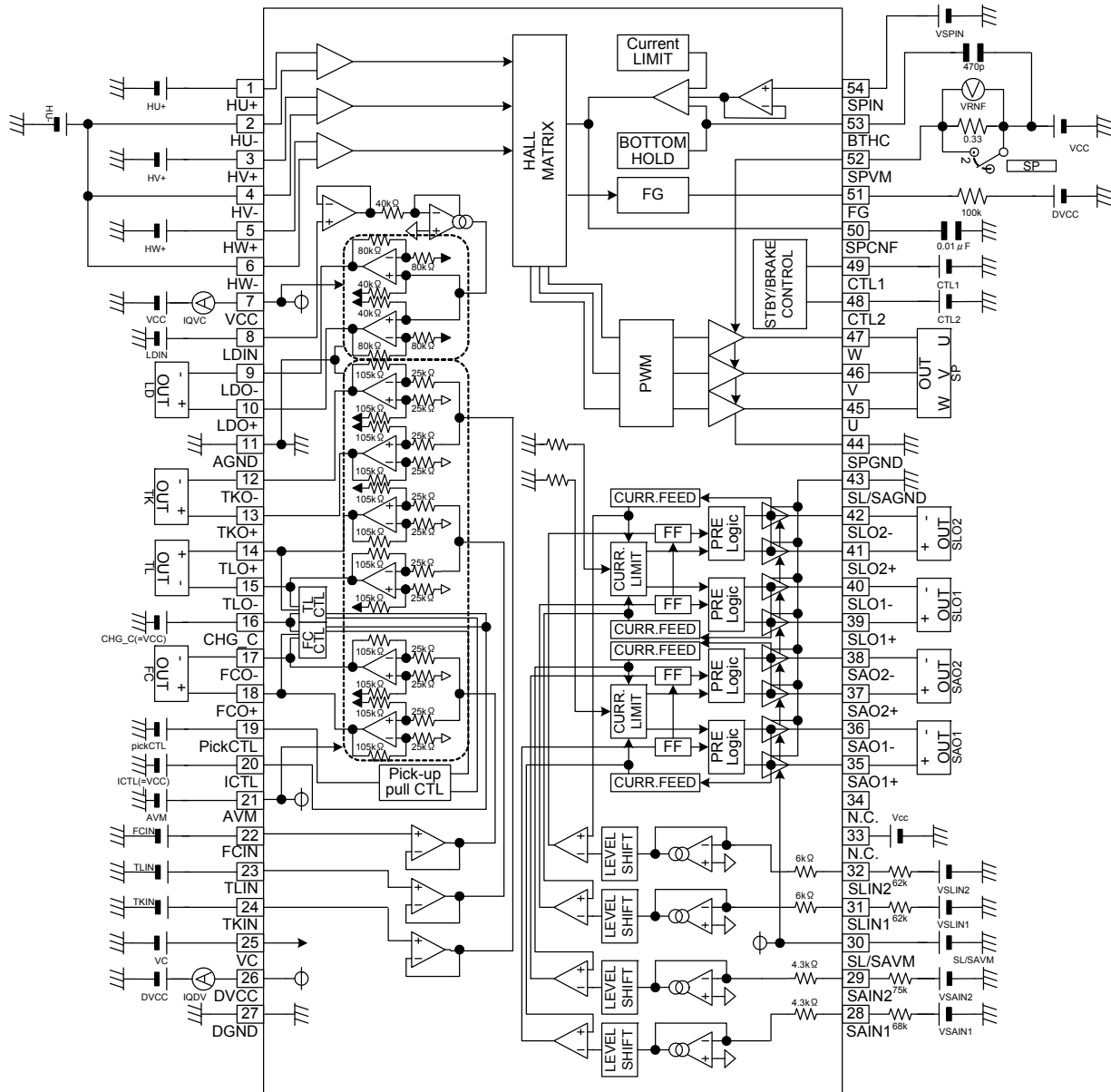

●Functional description

1. Driver logic control terminal 1and 2 (CTL1,2)

All drivers and spindle-drive braking modes can be switched on/off by inputting combinations of H-level signal (higher than 2V and lower than 3.7V) and L-level signal (lower than 0.5V) to these terminals.

CTL1	CTL2	Spindle	Sled	SA	Focus	Tracking	Tilt	Loading
L	L	×	×	×	×	×	×	×
H	L	×	×	×	×	×	×	○
—	H	○	○	○	○	○	○	×

①

②

○:ON ×:OFF

CTL1	CTL2	SPIN > VC	SPIN < VC
L	H	Forward-rotation mode	Reverse-rotation braking mode
H	H	Forward-rotation mode	Short-circuit braking mode

③

④

① Stand-by mode

The IC is brought into stand-by mode, and its power dissipation can be limited.

② Drivers muting

All output channels, except the loading, are muted and their outputs are turned off.

③ Reverse-rotation braking mode (spindle)

A reverse-rotation torque is applied when SPIN < VC.

Reverse-rotation is detected with SPIN input and Hall input. If the spindle detects reverse rotation when SPIN < VC, all the output are shorted to GND.

④ Short-circuit braking mode (spindle)

All the spindle driver outputs are shorted out to GND when SPIN < VC.

2. Input/Output timing chart

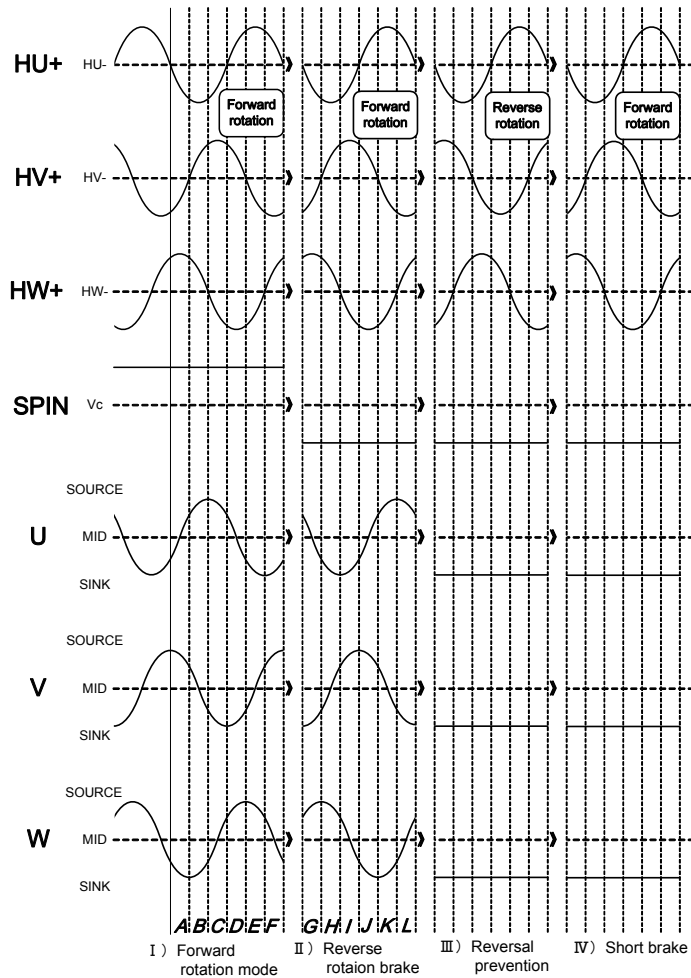

3. Pick-up lens pull function

Pick CTL	Function
L	ON ①
H	Normal (function:OFF) ②

① FOCUS and Tilt load are driven by the charge of the electrolytic capacitor connected with the CHG\_C terminal (16pin).

The load drive current flows as follows.

FCO- (17pin) → FCO+ (18pin)

TLO- (15pin) → TLO+ (14pin)

And the load drive current and time can be adjusted with the resistor and capacitor of CHG\_C (16pin) and ICTL (20pin).

② Please turn off this function by PickCTL=H when you use a usual driver.

4. Hall input(1 ~ 6pin)

The hall element can use both a series connection and a parallel connection.

However, please set the hall input voltage with 1.5-3.8V and 75mVpp or more (one side).

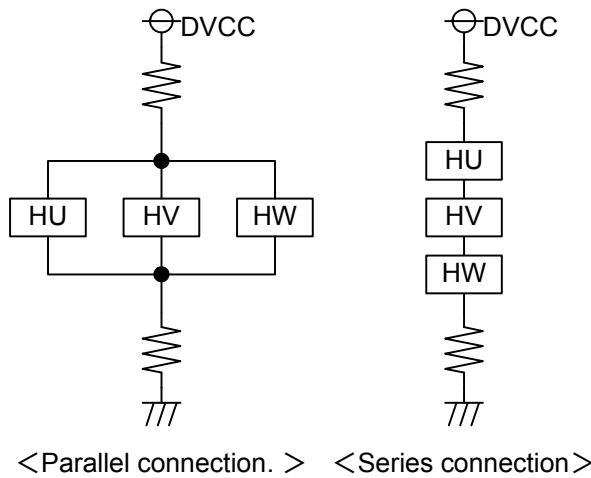

5. Torque command/ output current detection terminals

The relation between the torque command input and the output current detection terminals input is expressed in the figure below:

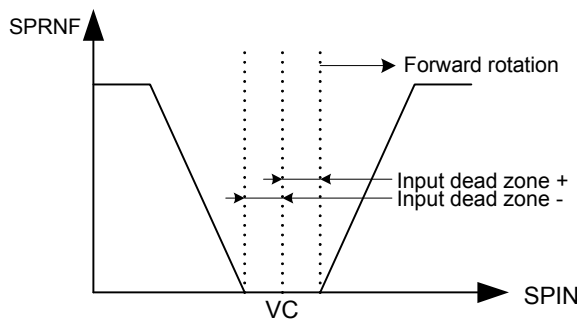

The input-output gain (gm) and the output-limit current (ILIM) depend on SPRNF (output current detection resistor).

6. PWM oscillation frequency

The PWM oscillation for driving the spindle, sled and SA is free running. The oscillating frequency is 100kHz(typ.)

7. Muting function

7-1) VC-drop muting

When the voltage at VC terminal drops to a value lower than 0.7V(Typ.), the outputs of all the channels are turned off. Set the VC terminal voltage higher than 1.0V.

7-2) Vcc-drop muting

When the voltage at DVcc terminal and Vcc terminal drops to a value lower than 3.8V(Typ.), the outputs of all the channels are turned off.

8. Thermal-shut down  
Thermal-shutdown circuit (over-temperature protection circuit) is built in to prevent the IC from thermal breakdown. Please use the IC according to the thermal loss allowed in the package. In case the IC is left running over the allowed loss, the junction temperature rises, and the thermal-shutdown circuit works at a junction temperature of 175°C(Typ.) (All other channel outputs are turned off).  
When the junction temperature drops to 150°C (Typ.) the IC resumes operation.
9. Protect system1  
The actuator protect system disables all output that exceeds 130ms (Typ.) at maximum power.  
\*It is possible to reset the protect system by CTL1,2=Low (Stand-by) in the protect operates.
10. Protection function 2  
Function to protect against destruction of output terminal (Focus, Tracking, Tilt, and Loading) when output pin connects to GND or Vcc.  
①When SINK side POWER transistor has been turned on, if the output current (400mA<Typ> or more) and the output voltage (Vcc-1VF or more) are detected, the channel concerned will be turned off.  
②When SOURCE side POWER transistor has been turned on, if the output current (1.6A<Typ> or more) are detected, the channel concerned will be turned off.  
\*It is possible to reset the protect system by CTL1,2=Low (Stand-by) in the protect operates.
11. 33pin, 34pin  
Please 33pin is a pull-up in Vcc and use, though it is N.C.  
Please make to open and use 34pin.

#### ●External parts description

- 1). Filtering capacitor  
It is recommended to connect 0.01μF filtering capacitor to SPCNF terminal. This capacitor filters PWM output carrier frequency. Dispersion of the cut off frequency due to circuit board wiring layout is taken into consideration. If it is difficult to filter at the recommended value due to circuit board wiring led round, the capacity can be increased. In this case, note that the output transmission delay time may be longer.
- 2). Bypass capacitor  
Please connect a bypass capacitor (0.1μF) across the supply voltage lines close to the IC pins.

## ●Notes for use

1. Absolute maximum ratings  
We are careful enough for quality control about this IC. So, there is no problem under normal operation, excluding that it exceeds the absolute maximum ratings. However, this IC might be destroyed when the absolute maximum ratings, such as impressed voltages ( $V_{cc}$ ,  $V_M$ ) or the operating temperature range( $T_{opr}$ ), is exceeded, and whether the destruction is short circuit mode or open circuit mode cannot be specified. Please take into consideration the physical countermeasures for safety, such as fusing, if a particular mode that exceeds the absolute maximum rating is assumed.
2. Reverse polarity connection of the power supply  
Connecting the power supply in reverse polarity can damage IC. Take precautions when connecting the power supply lines. An external direction diode can be added.
3. Power supply line  
Design PCB layout pattern to provide low impedance GND and supply lines. To obtain a low noise ground and supply line, separate the ground section and supply lines of the digital and analog blocks. Furthermore, for all power supply terminals to ICs, connect a capacitor between the power supply and the GND terminal. When applying electrolytic capacitors in the circuit, note that capacitance characteristic values are reduced at low temperatures.
4. GND voltage  
Ground-GND potential should maintain are the minimum ground voltage level. Furthermore, no terminals should be lower than the GND potential voltage including an electric transients.
5. Thermal design  
Do not exceed the power dissipation ( $P_d$ ) of the package specification rating under actual operation, and please design enough temperature margins.
6. Inner-pin shorts and mounting errors  
Use caution when positioning the IC for mounting on printed circuit boards. The IC may be damaged if there is any connection error or if positive and ground power supply terminals are reserved. The IC may also be damaged if pins are should together or are shorted to other circuits power lines.
7. Operation in a strong electromagnetic field  
Use caution when using the IC in the presence of a strong electromagnetic field as doing so many cause the IC to malfunction.
8. ASO(Area of Safety Operation.)  
Do not exceed the maximum ASO and the absolute maximum ratings of the output driver.
9. TSD(Thermal shut-down)  
The TSD is activated when the junction temperature ( $T_j$ ) reaches  $175^{\circ}\text{C}$ (with  $\pm 25^{\circ}\text{C}$  hysteresis), and the output terminal is switched to Hi-z. The TSD circuit aims to intercept IC from high temperature. The guarantee and protection of IC are not purpose. Therefore, don't use this IC after TSD circuit operates, or don't use it for assumption that operates the TSD circuit.
10. Capacitor between the output and GND  
If a large capacitor is connected between the output and GND, this IC might be destroyed when  $V_{cc}$  becomes 0V or GND, because the electric charge accumulated in the capacitor flows to the output. Please set said capacitor to smaller than  $0.1\mu\text{F}$ .
11. The capacitor between SPVM (52pin) and GND  
The capacitor between SPVM (52pin) and GND absorbs a sudden charge in the voltage and the current on account of PWM drive, and suppresses disorder of  $V_{cc}$  voltage. However if a capacitor becomes far from IC, the effect will fall under the influence of wiring impedance etc. Please arrange the capacitor between SPVM (52pin) and GND near the IC.

12. Wiring for SPRNF

Considering the wiring resistance, connect each detecting resistor as close as possible to the current detection terminals for the spindle drive SPRNF.

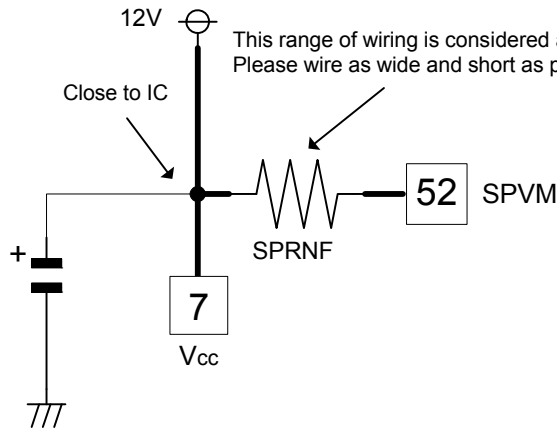

13. Earth wiring pattern

Use separate ground lines for control signals and high current power driver outputs. Because these high current output that flow to the wire impedance change the GND voltage for control signal. Therefore, each ground terminal of IC must be connected at the one point on the set circuit board. As for GND of external parts, it is similar to the above-mentioned.

14. Each input terminal

This IC is a monolithic IC, and has P<sup>+</sup> isolation and P substrate for the element separation. Therefore, a parasitic PN junction is formed in this P-layer and N-layer of each element. For instance, the resistor or the transistor is connected to the terminal as shown in the figure below. When the GND voltage potential is greater than the voltage potential at Terminals A or B, the PN junction operates as a parasitic diode. In addition, the parasitic NPN transistor is formed in said parasitic diode and the N layer of surrounding elements close to said parasitic diode. These parasitic elements are formed in the IC because of the voltage relation. The parasitic element operating causes the wrong operation and destruction. Therefore, please be careful so as not to operate the parasitic elements by impressing to input terminals lower voltage than GND (P substrate). Please do not apply the voltage to the input terminal when the power-supply voltage is not impressed. Moreover, please impress each input terminal lower than the power-supply voltage or equal to the specified range in the guaranteed voltage when the power-supply voltage is impressing.

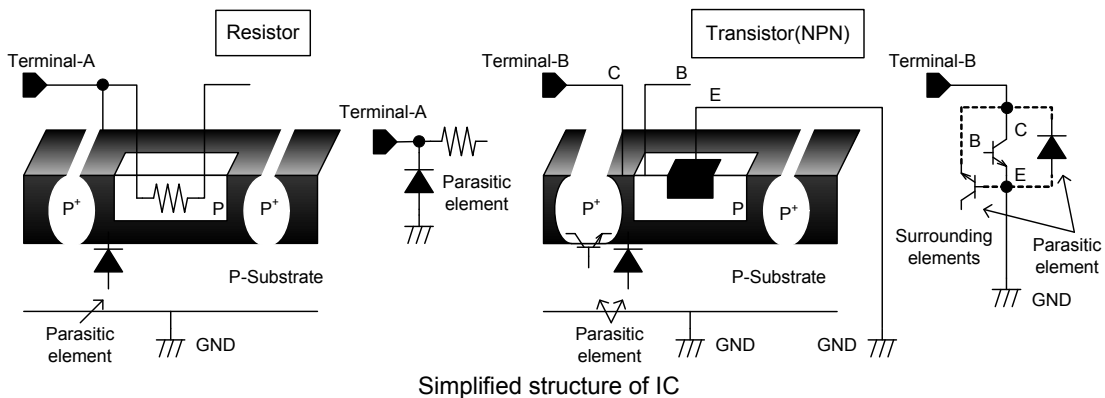

15. Inspection by the set circuit board

The stress might hang to IC by connecting the capacitor to the terminal with low impedance. Then, please discharge electricity in each and all process. Moreover, in the inspection process, please turn off the power before mounting the IC, and turn on after mounting the IC. In addition, please take into consideration the countermeasures for electrostatic damage, such as giving the earth in assembly process, transportation or preservation.

16. Belly metal

Belly metal pattern is attached to the GND on the inside of the package. Make sure to the external GND.

●Application circuit

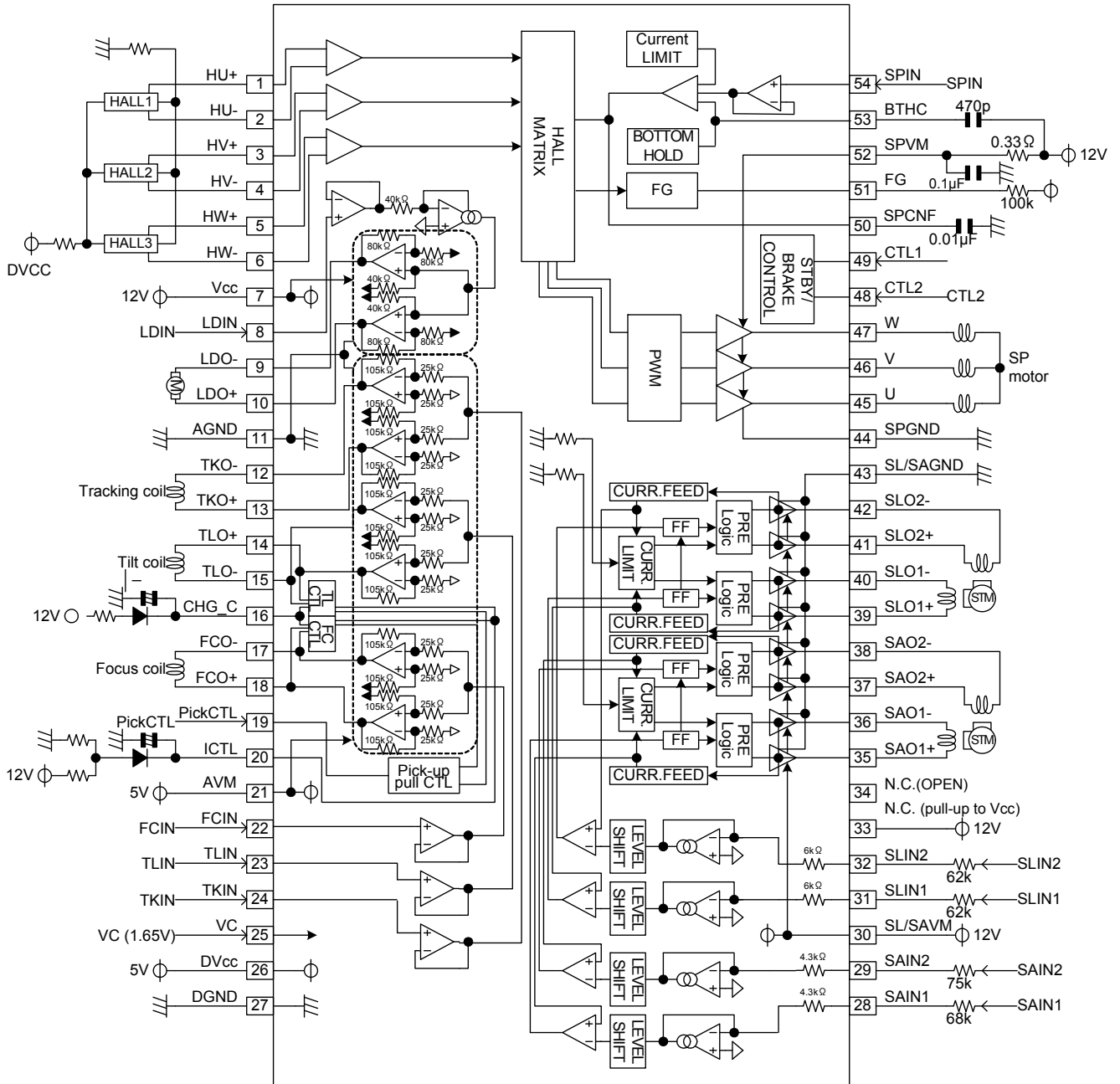

●Connecting wires of application board

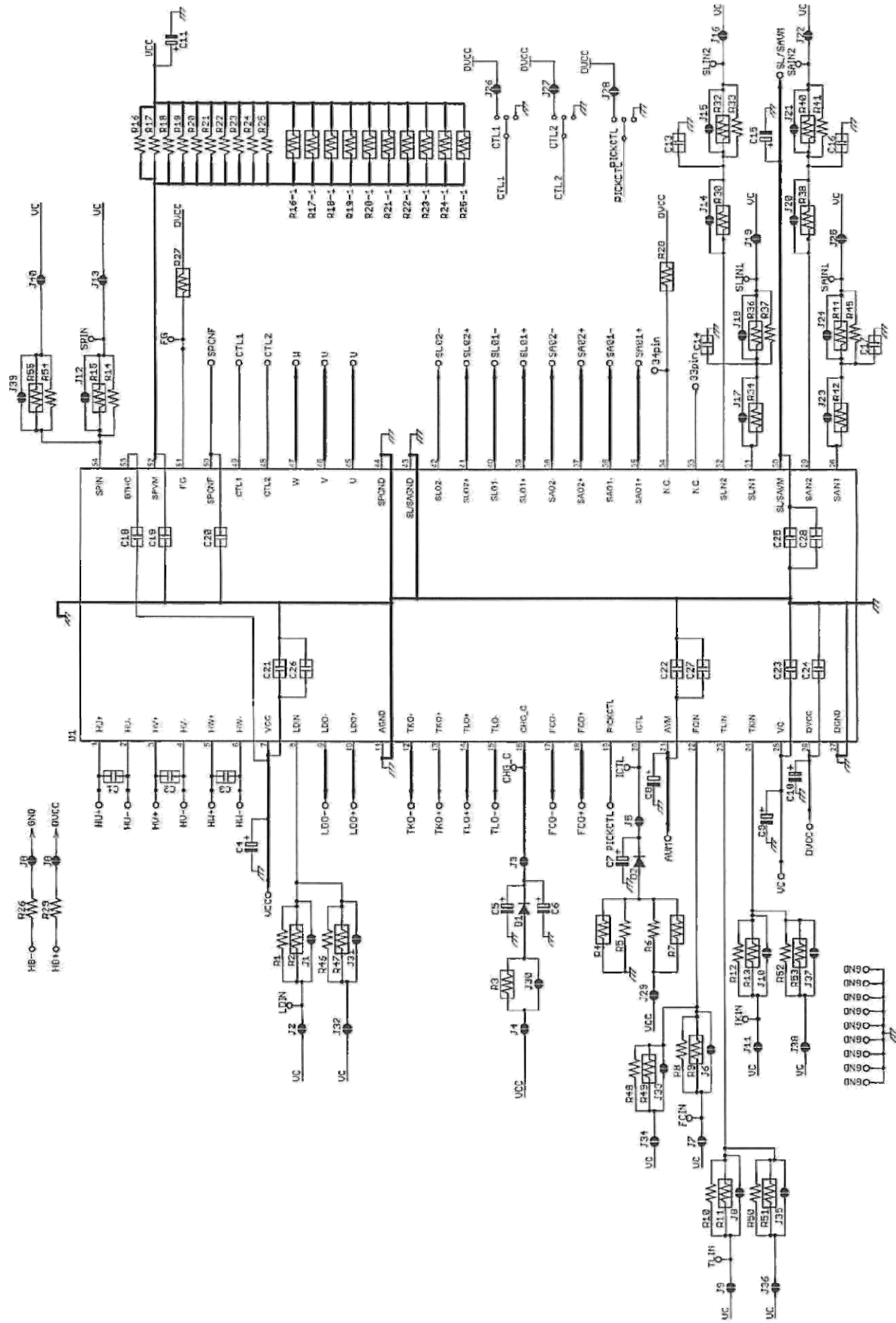

●Pattern drawing of application board

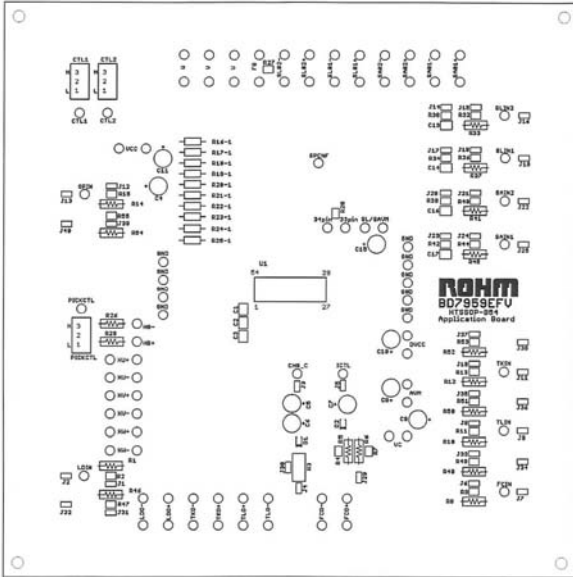

Silk screen on the surface

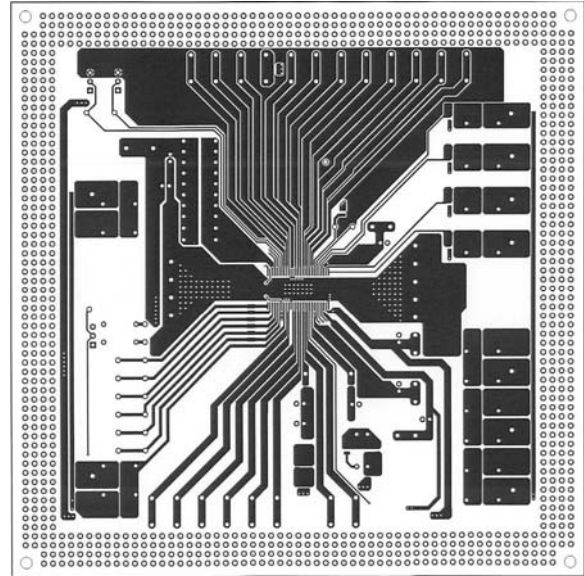

Wiring pattern on the surface

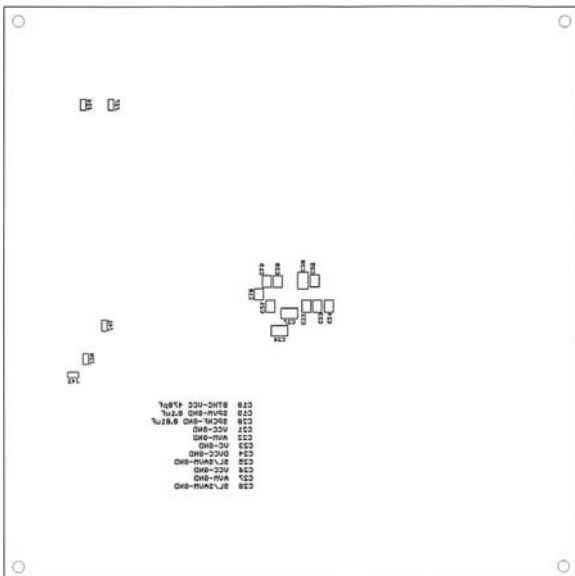

Silk screen on the back

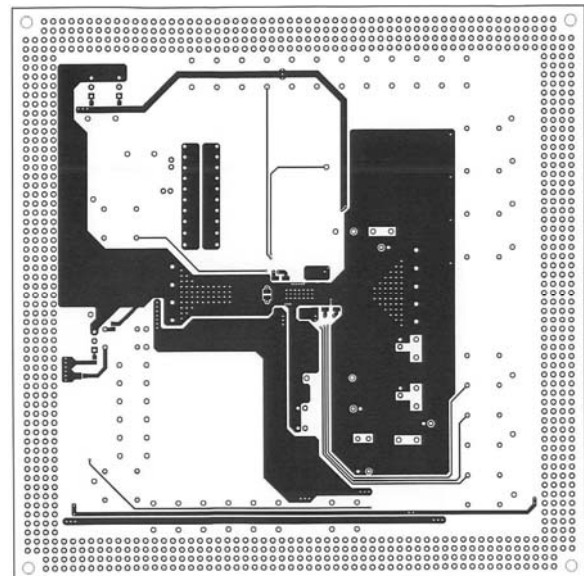

Wiring pattern on the back

●Electrical characteristic curves

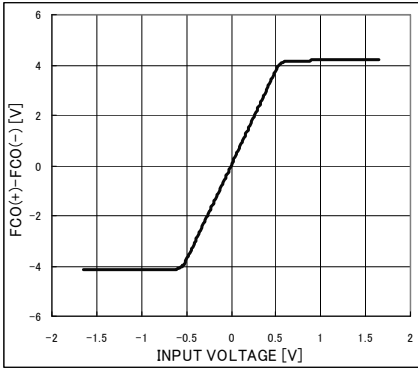

Fig.1 Focus driver I/O characteristic (Ta=27°C, RL=8Ω +47μH)

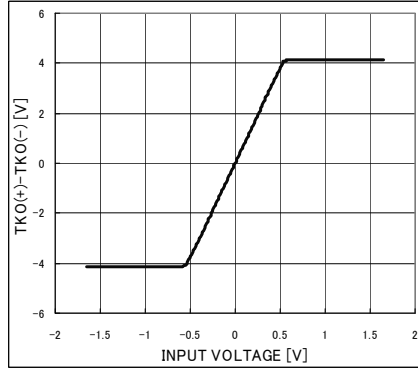

Fig.2 Tracking driver I/O characteristic (Ta=27°C, RL=8Ω +47μH)

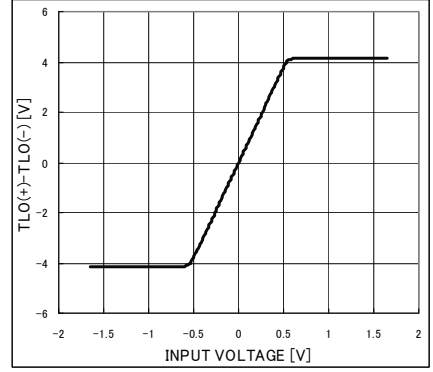

Fig.3 Tilt driver I/O characteristic (Ta=27°C, RL=8Ω +47μH)

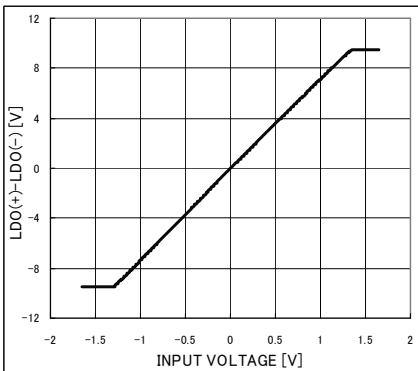

Fig.4 Loading driver I/O characteristic (Ta=27°C, RL=12Ω +47μH)

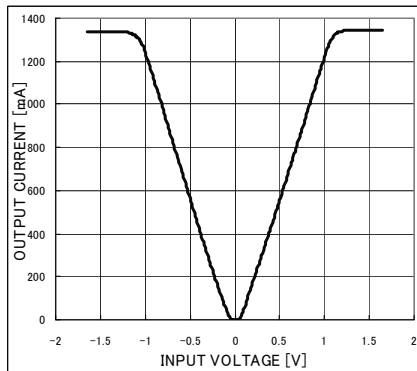

Fig.5 Sled driver I/O characteristic (Ta=27°C, RL=8Ω +47μH)

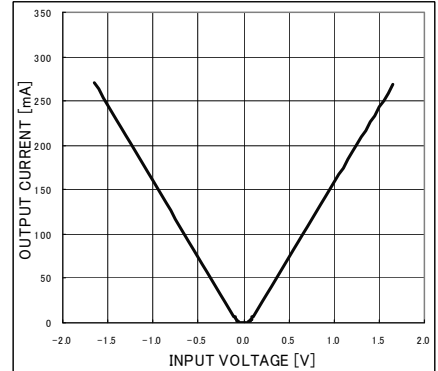

Fig.6 SA driver I/O characteristic (Ta=27°C, RL=8Ω +47μH)

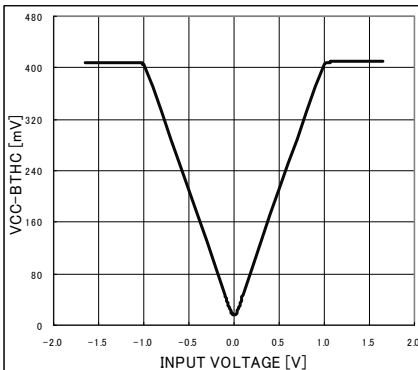
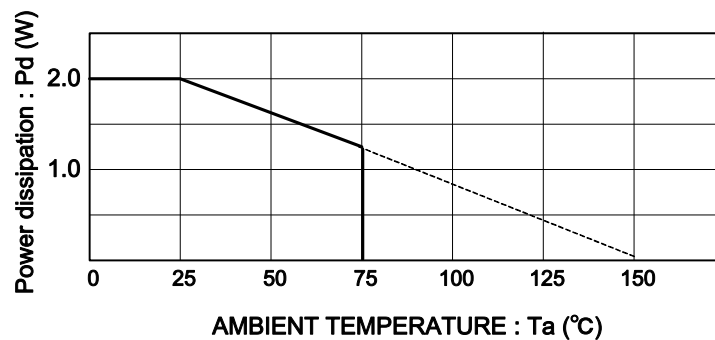

Fig.7 Spindle driver I/O characteristic (Ta=27°C, RL=2Ω +47μH)

●Power dissipation reduction



\*70mm × 70mm, t=1.6mm, occupied copper foil is less than 3%, glass epoxy mounting.

●Ordering part number

B	D
---	---

Part No.

7	9	5	9
---	---	---	---

Part No.

E	F	V
---	---	---

Package  
EFV: HTSSOP-B54

E	2
---	---

Packaging and forming specification  
E2: Embossed tape and reel

HTSSOP-B54

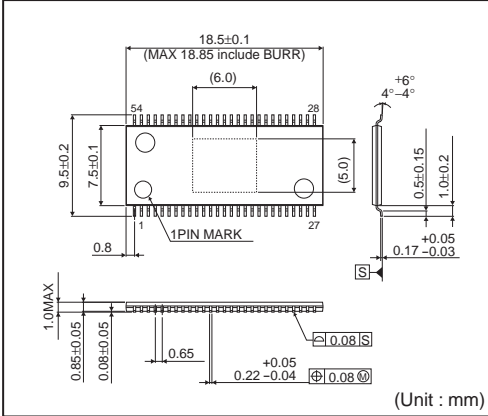

<Tape and Reel information>

Tape	Embossed carrier tape (with dry pack)
Quantity	1500pcs
Direction of feed	E2 ( The direction is the 1pin of product is at the upper left when you hold reel on the left hand and you pull out the tape on the right hand )

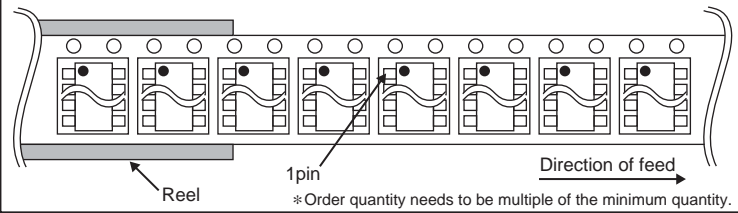

## Notes

No copying or reproduction of this document, in part or in whole, is permitted without the consent of ROHM Co.,Ltd.

The content specified herein is subject to change for improvement without notice.

The content specified herein is for the purpose of introducing ROHM's products (hereinafter "Products"). If you wish to use any such Product, please be sure to refer to the specifications, which can be obtained from ROHM upon request.

Examples of application circuits, circuit constants and any other information contained herein illustrate the standard usage and operations of the Products. The peripheral conditions must be taken into account when designing circuits for mass production.

Great care was taken in ensuring the accuracy of the information specified in this document. However, should you incur any damage arising from any inaccuracy or misprint of such information, ROHM shall bear no responsibility for such damage.

The technical information specified herein is intended only to show the typical functions of and examples of application circuits for the Products. ROHM does not grant you, explicitly or implicitly, any license to use or exercise intellectual property or other rights held by ROHM and other parties. ROHM shall bear no responsibility whatsoever for any dispute arising from the use of such technical information.

The Products specified in this document are intended to be used with general-use electronic equipment or devices (such as audio visual equipment, office-automation equipment, communication devices, electronic appliances and amusement devices).

The Products specified in this document are not designed to be radiation tolerant.

While ROHM always makes efforts to enhance the quality and reliability of its Products, a Product may fail or malfunction for a variety of reasons.

Please be sure to implement in your equipment using the Products safety measures to guard against the possibility of physical injury, fire or any other damage caused in the event of the failure of any Product, such as derating, redundancy, fire control and fail-safe designs. ROHM shall bear no responsibility whatsoever for your use of any Product outside of the prescribed scope or not in accordance with the instruction manual.

The Products are not designed or manufactured to be used with any equipment, device or system which requires an extremely high level of reliability the failure or malfunction of which may result in a direct threat to human life or create a risk of human injury (such as a medical instrument, transportation equipment, aerospace machinery, nuclear-reactor controller, fuel-controller or other safety device). ROHM shall bear no responsibility in any way for use of any of the Products for the above special purposes. If a Product is intended to be used for any such special purpose, please contact a ROHM sales representative before purchasing.

If you intend to export or ship overseas any Product or technology specified herein that may be controlled under the Foreign Exchange and the Foreign Trade Law, you will be required to obtain a license or permit under the Law.



Thank you for your accessing to ROHM product informations.  
More detail product informations and catalogs are available, please contact us.

## ROHM Customer Support System

<http://www.rohm.com/contact/>