

■Structure	Silicon Monolithic Integrated Circuit
■Product Name	For DSC/DVC motor driving IC
■Model Name	<b>BD5520GU</b>
■Physical Dimension	Fig.1
■Block Diagram	Fig.2
■Terminal equivalent circuit diagram	Fig.3
■Function	<ul style="list-style-type: none"><li>·Power MOS-H bridge 4ch</li><li>·Comparator 2ch</li><li>·Under voltage protection circuit</li><li>·Over voltage protection circuit</li></ul>

•A radiation is not designed.

■Physical Dimension

Package type name: VCSP85H2

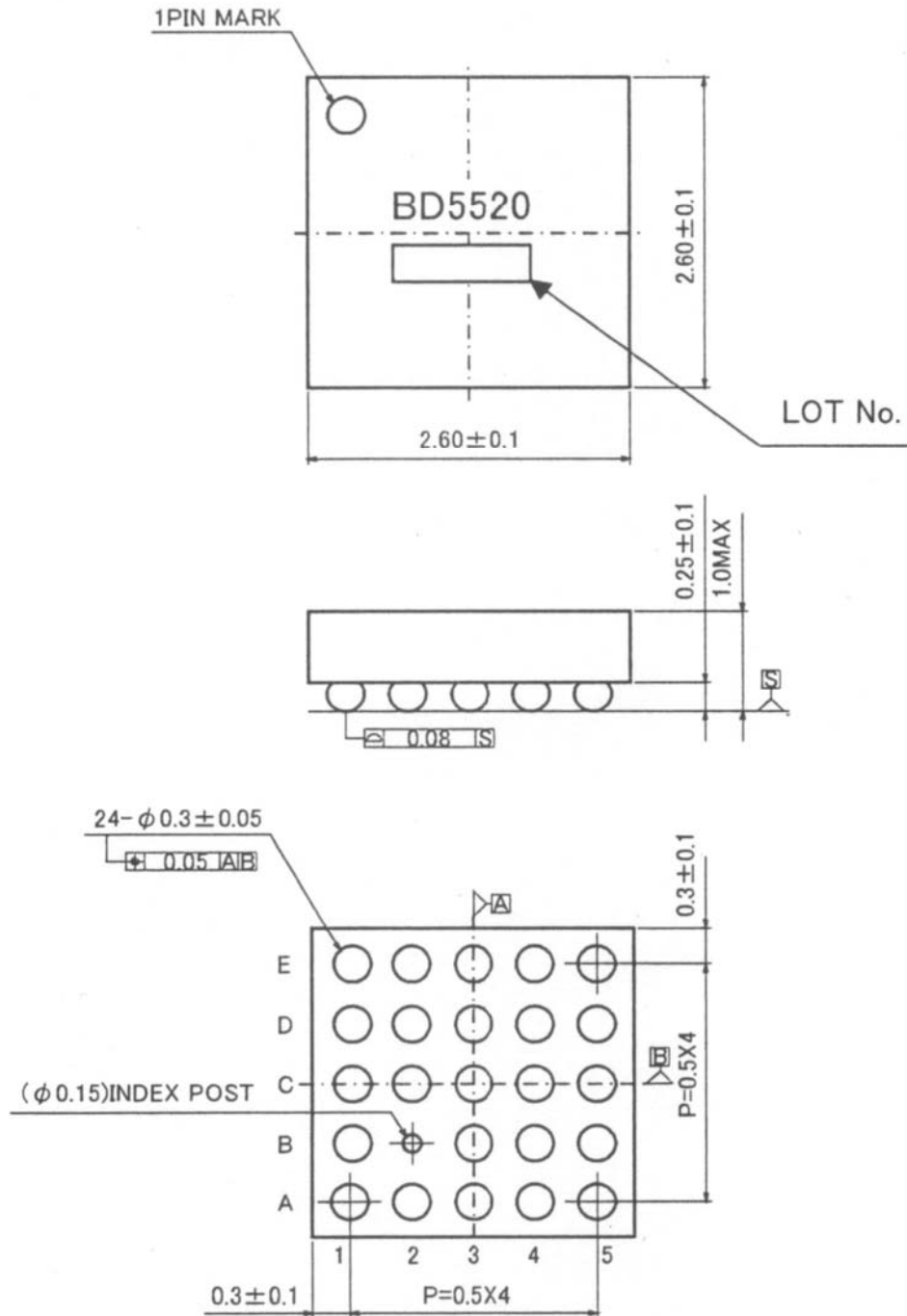

Fig-1 Physical Dimension (Unit: mm)

■CHIP Backside PIN Arrangement

E	OUT2F	IN2A	CPI1	IN3A	OUT3F
D	OUT2R	VCC1	CP01	IN3B	OUT3R
C	GND1	IN1B	IN2B	IN4B	GND2
B	OUT1R		CP02	VCC2	OUT4R
A	OUT1F	IN1A	CPI2	IN4A	OUT4F
	1	2	3	4	5

■Each terminal explanation

PIN No.	Terminal name	Terminal explanation
1-A	OUT1F	HBRIDGE CH1 Forward output
2-A	IN1A	HBRIDGE CH1 input
3-A	CPI2	Comparator2 input
4-A	IN4A	HBRIDGE CH4 input A
5-A	OUT4F	HBRIDGE CH4 Forward output
1-B	OUT1R	HBRIDGE CH1 Reverse output
2-B	-	-
3-B	CP02	Comparator2 output
4-B	VCC2	VCC voltage
5-B	OUT4R	HBRIDGE CH4 Reverse output
1-C	GND1	Ground
2-C	IN1B	HBRIDGE CH1 input B
3-C	IN2B	HBRIDGE CH2 input B
4-C	IN4B	HBRIDGE CH4 input B
5-C	GND2	Ground
1-D	OUT2R	HBRIDGE CH2 Reverse output
2-D	VCC1	VCC voltage
3-D	CP01	Comparator1 output
4-D	IN3B	HBRIDGE CH3 input B
5-D	OUT3R	HBRIDGE CH3 Reverse output
1-E	OUT2F	HBRIDGE CH2 Forward output
2-E	IN2A	HBRIDGE CH2 input A
3-E	CPI1	Comparator1 input
4-E	IN3A	HBRIDGE CH3 input A
5-E	OUT3F	HBRIDGE CH3 Forward output

■ Measurement circuit diagram

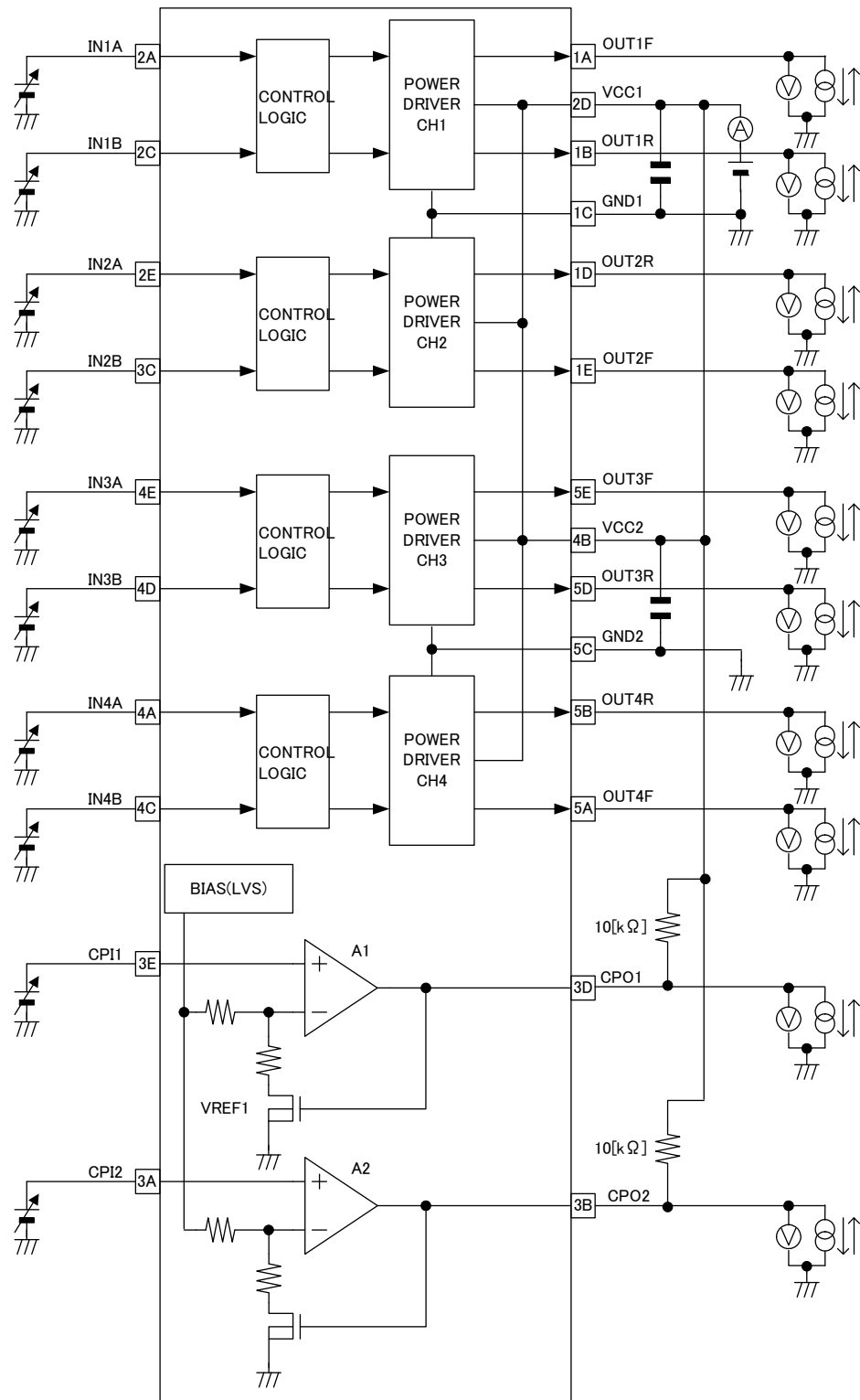

Fig-2 Measurement circuit



■ Absolute maximum ratings

Item	Symbol	Standard value	Unit
Power supply voltage	VCC	7.0	V
H Bridge output current1	IOUT1	200	mA
H Bridge output current2	IOUT2	300	mA
Power dissipation (*2)	PD	505	mW
Operation temperature range	TOPR	-10~70	°C
Storage temperature range	TSTG	-40~125	°C

(\*1) Instantaneous current (1[us] or less)

(\*2) Mounting board specification (Rohm standard board)

Material : The glass fabric base epoxy Dimensions : 50[mm]×58[mm]×1.75[mm] (8 layers)

■ Operating condition

Item	Symbol	Min.	Typ.	Max.	Unit
VCC power supply voltage	VCC	2.4	5.0	5.5	V
Comparator Pull up resistance	CPR	7.5	-	-	kΩ

■ Power dissipation (Mounting board)

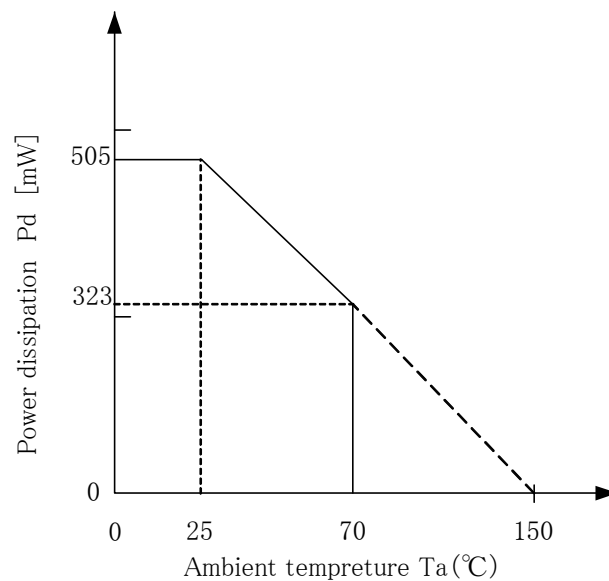

Mounting board specification (Rohm standard board)

Material : The glass fabric

Size : 550[mm]×58[mm]×1.75[mm] (8 layers) (8 layers)

**■Electrical characteristic**

◎Circuit current (VCC=5.0[V], Ta=25[°C] except as otherwise noted)

Item	Symbol	Standard value			Unit	Notes
		Min.	Typ.	Max.		
Current consumption at standby	SICC	—	(1)	10	μA	At IN*A=IN*B=CPI*=L
Current consumption when operating	BICC	—	410	615	μA	RL=Open, At IN*A=H, IN*B=L, CPI*=L The current that flows to comp pull up R is excluded.

◎AMP (VCC=5.0[V], Ta=25[°C] except as otherwise noted)

Item	Symbol	Standard value			Unit	Notes
		Min.	Typ.	Max.		
<COMP AMP (A1·A2)>						
Input current	CPIIL	—	—	1	μA	
Output terminal voltage L	CPOUTL	—	0.07	0.3	V	AMP*IN 0.0[V] At 10[kΩ] pull up R
Output leak current	CPOUTIL	—	—	1	μA	AMP*IN 3.3[V]
Reference voltage	CPBIAS	1.7	1.8	1.9	V	AMP*IN 0→3.3[V]
Hysteresis voltage	CPHYS	300	400	500	mV	
Delay time R	CPRISE	—	0.4	10	μs	AMP*IN 3.3→0[V] At 10[kΩ] pull up R
Delay time F	CPFALL	—	0.4	10	μs	AMP*IN 0→3.3[V] At 10[kΩ] pull up R

◎H-BRIDGE (VC=5.0[V], Ta=25[°C] RL=OPEN, CL=0[pF] except as otherwise noted)

Item	Symbol	Standard value			Unit	Notes
		Min.	Typ.	Max.		
<Logic interface input (IN*A, IN*B)>						
L input voltage	LVIL	GND	—	0.5	V	
H input voltage	LVIH	2.0	—	VCC	V	
L input current	LIIL	-1	—	—	μA	L input =0[V]
H input current	LIH	21.0	35.0	52.5	μA	H input =3.3[V]
<Driver output (OUT*F, OUT*R)>						
Output on resistance	HRON	—	0.85	1.4	Ω	The sum of on resistance at the top and bottom I=100[mA]
Output delay time	HtRISE	—	0.1	2	μsec	
	HtFALL	—	0.1	2	μsec	
Minimum output pulse width	HtMIN	400	—	—	nsec	output pulse width 1/2tMIN more

■Electrical characteristic

◎Power-supply voltage detection circuit (VCC=5.0[V], Ta=25[°C] except as otherwise noted)

Item	Symbol	Standard value			Unit	Notes
		Min.	Typ.	Max.		
Start up time	StartTime	-	4.0	10.0	$\mu$ s	Stand by→Driver ON time
<Under voltage detection circuit >						
Threshold voltage	LVS Vth+	2.20	2.30	2.40	V	
	LVS Vth-	2.10	2.20	2.30	V	
Hysteresis voltage	LVS HYS	50	100	150	mV	
Operation lower bound voltage	LVS OP	-	-	1	V	
<Over voltage detection circuit>						
Threshold voltage	HVS Vth	6.35	6.50	6.65	V	

◎Logic input truth table

Input signal		Output singal		• Comparator • voltage detection circuit
IN*A	IN*B	OUT*F	OUT*R	
H	L	H	L	Operation
H	H	L	L	Operation
L	H	L	H	Operation
L	L	Hiz	Hiz	Ready

(※1)When all ch is a ready state, it becomes a standby.

**■ Directions****1. Absolute maximum ratings**

This IC might be destroyed when the absolute maximum ratings, such as impressed voltages (VC,PVCC,VDD) or the operating temperature range (TOPR) is exceeded, and whether the destruction is short circuit mode or open circuit mode cannot be specified. Please take into consideration the physical countermeasures for safety, such as fusing, if a particular mode that exceeds the absolute maximum rating is assumed.

**2. Reverse polarity connection**

Connecting the power line to the IC in reverse polarity (from that recommended) will damage the part. Please utilize the direction protection device as a diode in the supply line.

**3. Power supply line**

Due to switching and EMI noise generated by magnetic components (inductors and motors), using electrolytic and ceramic suppress filter capacitors close to the IC power input terminals (Vcc and GND) is recommended. Please note: the electrolytic capacitor value decreases at lower temperatures.

**4. GND line**

The ground line is where the lowest potential and transient voltages are connected to the IC.

**5. Thermal design**

Do not exceed the power dissipation (Pd) of the package specification rating under actual operation, and please design enough temperature margins. (Refer to page 6.)

**6. Short circuit mode between terminals and wrong mounting**

Do not mount the IC in the wrong direction and be careful about the reverse-connection of the power connector. Moreover, this IC might be destroyed when the dust short the terminals between them or GND.

**7. Radiation**

Strong electromagnetic radiation can cause operation failures.

**8. ASO(Area of Safety Operation.)**

Do not exceed the maximum ASO and the absolute maximum ratings of the output driver.

**9. TSD(Thermal shut-down)**

The TSD is activated when the junction temperature (Tj) reaches 175°C(with +/-25°C hysteresis), and the output terminal is switched to Hi-z. The TSD circuit aims to intercept IC from high temperature. The guarantee and protection of IC are not purpose. Therefore, please do not use this IC after TSD circuit operates, nor use it for assumption that operates the TSD circuit.

**10. Capacitor between output and GND**

If a large capacitor is connected between the output and GND, this IC might be destroyed when Vcc becomes 0V or GND, because the electric charge accumulated in the capacitor flows to the output. Please set said capacitor to smaller than 0.1 μF.

11. Inspection by the set circuit board

The stress might hang to IC by connecting the capacitor to the terminal with low impedance. Then, please discharge electricity in each and all process. Moreover, in the inspection process, please turn off the power before mounting the IC, and turn on after mounting the IC. In addition, please take into consideration the countermeasures for electrostatic damage, such as giving the earth in assembly process, transportation or preservation.

12. Each input terminal

This IC is a monolithic IC, and has P<sup>+</sup> isolation and P substrate for the element separation. Therefore, a parasitic PN junction is formed in this P-layer and N-layer of each element. For instance, the resistor or the transistor is connected to the terminal as shown in the figure below. When the GND voltage potential is greater than the voltage potential at Terminals A or B, the PN junction operates as a parasitic diode. In addition, the parasitic NPN transistor is formed in said parasitic diode and the N layer of surrounding elements close to said parasitic diode. These parasitic elements are formed in the IC because of the voltage relation. The parasitic element operating causes the wrong operation and destruction. Therefore, please be careful so as not to operate the parasitic elements by impressing to input terminals lower voltage than GND(P substrate). Please do not apply the voltage to the input terminal when the power-supply voltage is not impressed. Moreover, please impress each input terminal lower than the power-supply voltage or equal to the specified range in the guaranteed voltage when the power-supply voltage is impressing.

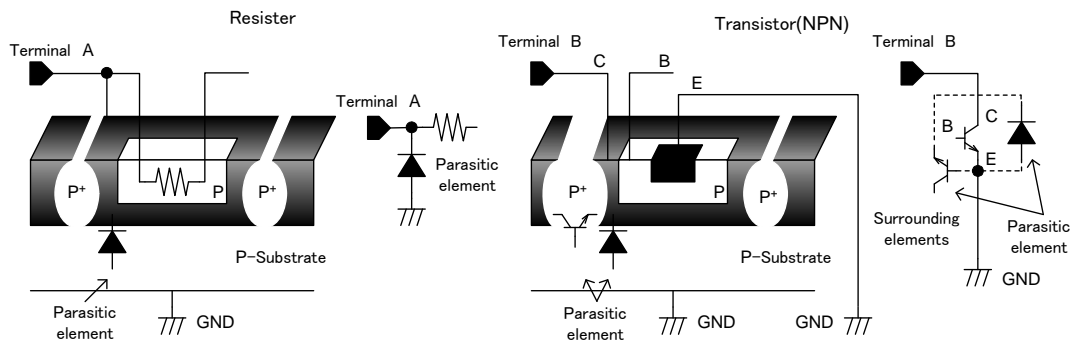

Simplified structure of IC

13. Earth drawing pattern

- Please lower in plenty the electric impedance for VCC and GND supply line.
- In this IC, comparator GND and driver GND are designed the same terminal. Because the size of the chip has been miniaturized. Inside of this IC, GND supply line is separated and connected one point of the terminal. Please note that the GND supply voltage is not any changed.

14. Reverse brake

When you do the reversal brake from the high-velocity revolution note the counter electromotive force. Moreover, confirm the output current enough and examine the rotational speed which uses the reversal brake.

15. About the capacitor between VCC-GND

The VCC-GND capacitor absorbs the change in a steep voltage and the current because of the PWM drive. As a result, there is a role to suppress the disorder of the VCC voltage. However, the effect decreases by the influence of the wiring impedance etc. if the capacitor becomes far from IC. Arrange the VCC-GND capacitor near IC.

16. Bypass capacitor

Between the supply power supplies connect the bypass capacitor(0.1 μF) near the pin of this IC.

## Notes

No copying or reproduction of this document, in part or in whole, is permitted without the consent of ROHM Co.,Ltd.

The content specified herein is subject to change for improvement without notice.

The content specified herein is for the purpose of introducing ROHM's products (hereinafter "Products"). If you wish to use any such Product, please be sure to refer to the specifications, which can be obtained from ROHM upon request.

Examples of application circuits, circuit constants and any other information contained herein illustrate the standard usage and operations of the Products. The peripheral conditions must be taken into account when designing circuits for mass production.

Great care was taken in ensuring the accuracy of the information specified in this document. However, should you incur any damage arising from any inaccuracy or misprint of such information, ROHM shall bear no responsibility for such damage.

The technical information specified herein is intended only to show the typical functions of and examples of application circuits for the Products. ROHM does not grant you, explicitly or implicitly, any license to use or exercise intellectual property or other rights held by ROHM and other parties. ROHM shall bear no responsibility whatsoever for any dispute arising from the use of such technical information.

The Products specified in this document are intended to be used with general-use electronic equipment or devices (such as audio visual equipment, office-automation equipment, communication devices, electronic appliances and amusement devices).

The Products specified in this document are not designed to be radiation tolerant.

While ROHM always makes efforts to enhance the quality and reliability of its Products, a Product may fail or malfunction for a variety of reasons.

Please be sure to implement in your equipment using the Products safety measures to guard against the possibility of physical injury, fire or any other damage caused in the event of the failure of any Product, such as derating, redundancy, fire control and fail-safe designs. ROHM shall bear no responsibility whatsoever for your use of any Product outside of the prescribed scope or not in accordance with the instruction manual.

The Products are not designed or manufactured to be used with any equipment, device or system which requires an extremely high level of reliability the failure or malfunction of which may result in a direct threat to human life or create a risk of human injury (such as a medical instrument, transportation equipment, aerospace machinery, nuclear-reactor controller, fuel-controller or other safety device). ROHM shall bear no responsibility in any way for use of any of the Products for the above special purposes. If a Product is intended to be used for any such special purpose, please contact a ROHM sales representative before purchasing.

If you intend to export or ship overseas any Product or technology specified herein that may be controlled under the Foreign Exchange and the Foreign Trade Law, you will be required to obtain a license or permit under the Law.



Thank you for your accessing to ROHM product informations.  
More detail product informations and catalogs are available, please contact us.

## ROHM Customer Support System

<http://www.rohm.com/contact/>