

Package : VSON***X series

(A table of contents)

1. Structure and materials	1/4 page
2. Tape and Reel informations	1/4to3/4 page
3. Storage conditions	3/4 page
4. Marking lot number	3/4 page
5. Footprint dimensions	3/4 page
6. Recommended soldering	3/4to4/4page

1. Structure and materials

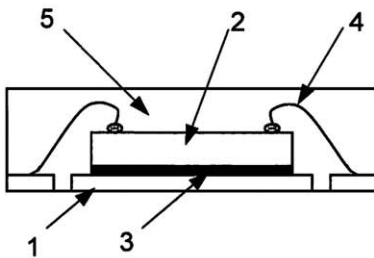

Fig. 1 Structure

No.	Item	Materials
1	Lead Frame	Cu-Alloy (External lead : Pb free solder plating)
2	Die	Silicon
3	Die Attach	Ag Paste
4	Wire	Au
5	Molding	Epoxy Resin

2. Tape and Reel information

2.1. Packing specification

Tape	Embossed carrier tape
Quantity	See the table on page 4/4
Direction of feed	TR(See Fig. 2)

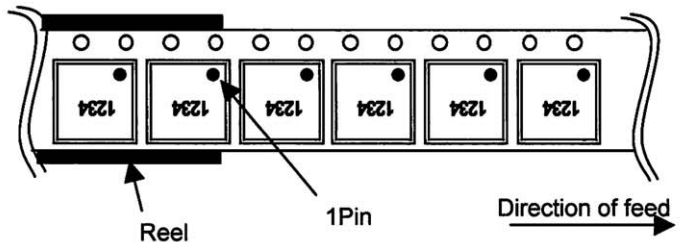

Fig. 2 Typical Tape and Reel configuration

2.2. Tape and Reel specification

2.2.1. Tape and reel dimensions (See the table on page 4/4)

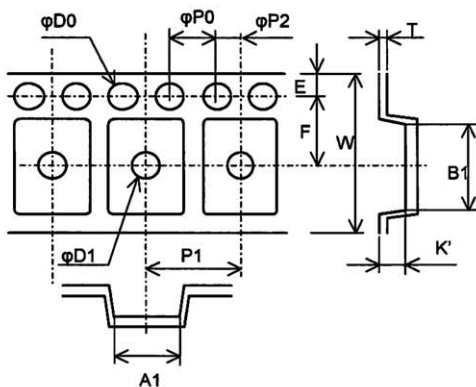

Fig. 3 Tape dimensions

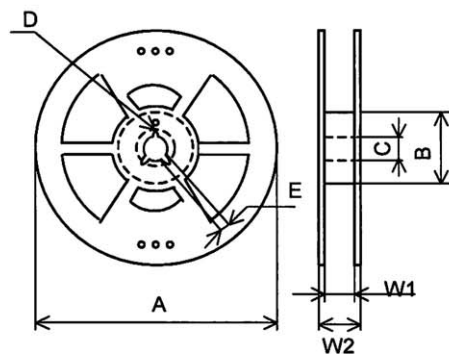

Fig. 4 Reel dimensions

2.3.Leader and Trailer

2.3.1.Leader

No component pockets are 25 pockets or more.

2.3.2.Trailer

No component pockets are 10 pockets or more.

Tape is free from reel.

2.4.Label for Reel and Box

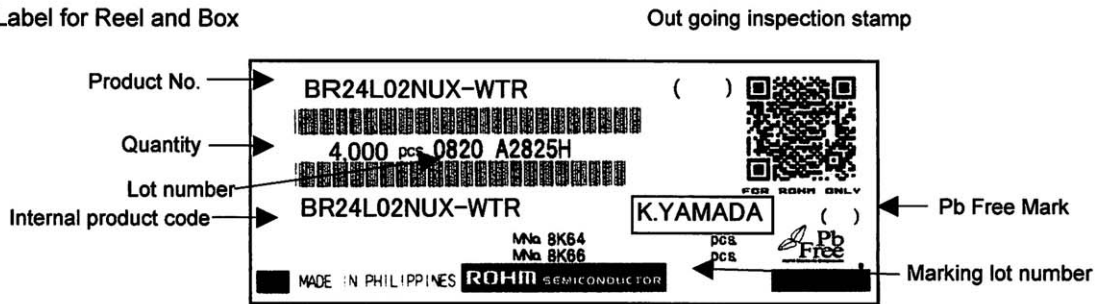

Fig.5 Label example

2.5.Packing style

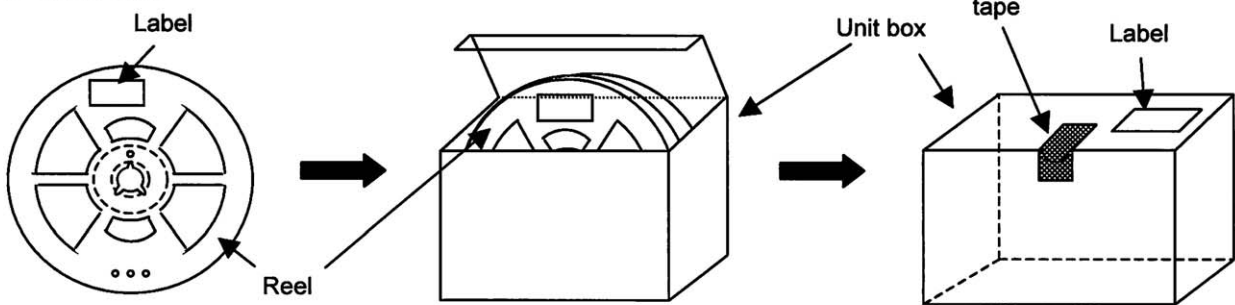
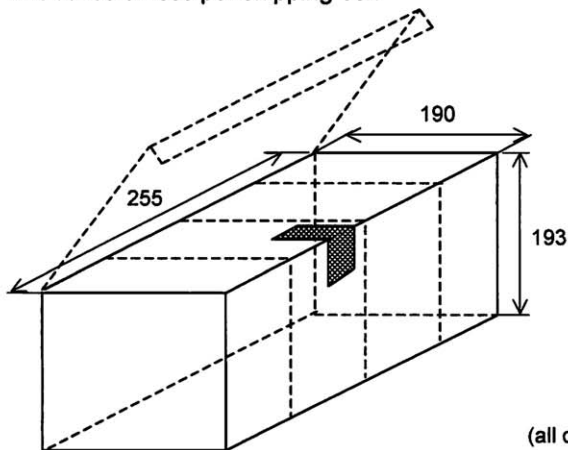

Fig. 6 Packing style

2.6.Shipping style

4 unit boxes or less per shipping box



(all dimensions in mm)

2.7.Packing materials

Item	Material
Embossed carrier tape	PS
Cover tape	PET + PE
Reel	PS
Unit box	Cardboard
Shipping box	Cardboard

2.8.Others

2.8.1.Peelback strength

Cover tape peelback strength is 0.2to0.7N.

Fig. 8 Test method

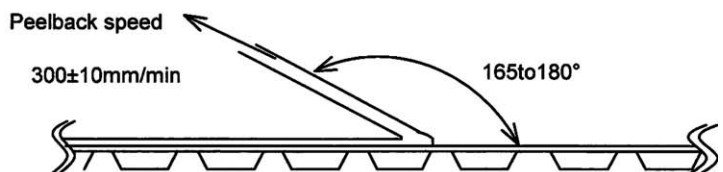

2.8.2.Dropouts

- (1)No consecutive dropouts.
- (2)A maximum 0.1% of specified number of products in each packing may be missing.

3.Storage conditions

3.1.Storage environment

Recommended storage conditions are as follows :

- Temperature : 5to30°C
- Humidity : 40to70% RH

3.2.Storage period

- Specified storage period : 1year

4.Marking lot number

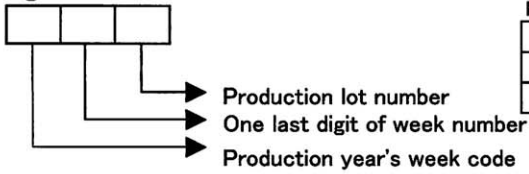

Production year's week code

Week	0	1	2	3	4	5
Even year	A	B	C	D	E	F
Odd year	U	V	W	X	Y	Z

5.Footprint dimensions (Optimize footprint dimensions to the board design and soldering condition)

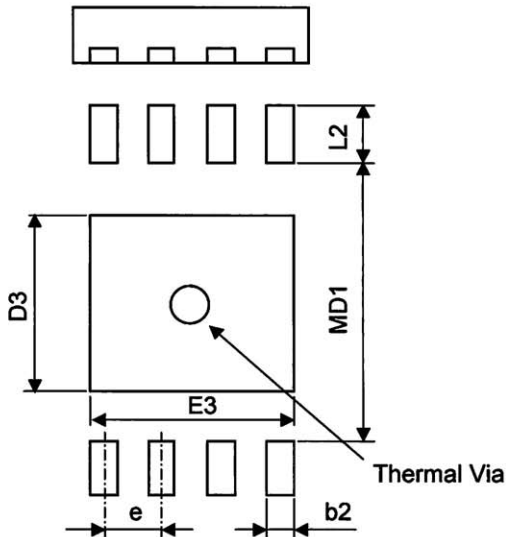

(all dimensions in mm)

Package	Land pitch e	Land space MD1	Land length ≥L2	Land width b2
VSON008X2030	0.50	2.20	0.70	0.27

Package	Radiation land length D3	Radiation land width E3	Thermal via	
			Pitch	Diameter
VSON008X2030	1.20	1.60	-	φ0.3

*The lead toe and lead side fillet may not be achieved because of non-lead packages.

6.Soldering conditions

6.1.Recommended temperature profile for reflow

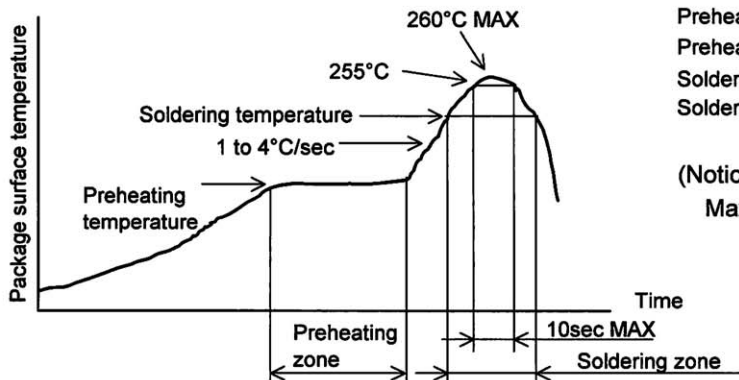

- Preheating temperature ; 130°C to 190°C
- Preheating zone ; 120sec MAX
- Soldering temperature ; 220°C to 230°C
- Soldering zone ; 60sec MAX

(Notice)
Maximum 2-times soldering

6.2. The wave soldering method is not supported.

6.3 Notice information of board mounting

Mounting on flexible film

Mounting on flexible film, film bend may occur lack of lead from package, usage of support board and under fill is recommended.

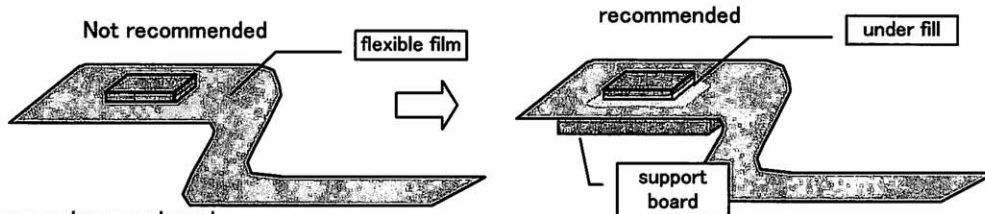

Mounting on long and narrow board

Mounting on long and narrow board, bending stress may occur a lack of lead from package, bending board direction and outer lead direction is recommended as drawing (vertically layout) and under fill usage is recommended.

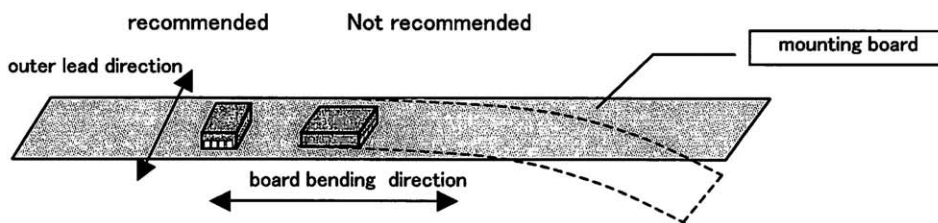

6.4 Rework by solering iron is not allowed or it may cause mold crack and terminal open.

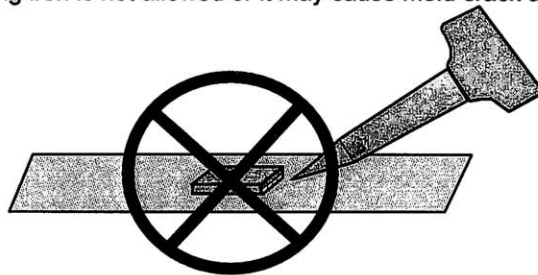

(Tape dimensions)

Package	Quantity (pcs)	Tape dimensions (all dimensions in mm)											
		A1	B1	D0	D1	E	F	K'	P0	P1	P2	T	W
VSON008X2030	4000	2.25 ±0.1	3.25 ±0.1	φ1.5 +0.1/0	φ1.0 ±0.1	1.75 ±0.1	5.5 ±0.05	0.85 ±0.1	4.0 ±0.1	4.0 ±0.1	2.0 ±0.05	0.3 ±0.05	12.0 ±0.2

<Reel dimensions >

<Dehydrated weight >

Package	Reel dimensions (all dimensions in mm)						
	A	B	C	D	E	W1	W2
VSON008X2030	φ180	φ60	φ13.0	φ20.2	1.5	13.0	15.4
Tolerance	-	+1.0/0	±0.2	MIN	MIN	+1.0/0	±1.0

Dehydrated weight (g)
0.009

Package Dimensions

VSON008X2030

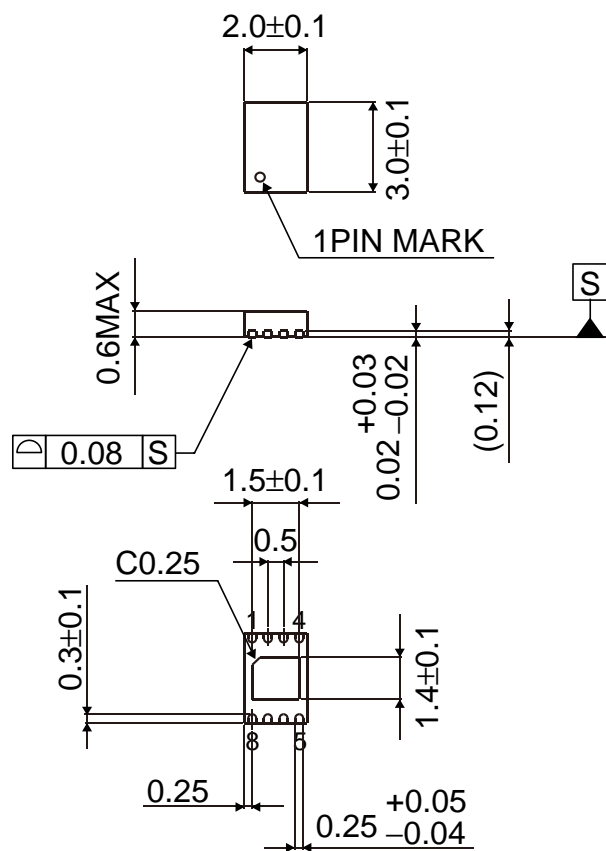

(Unit : mm)

Notes

No copying or reproduction of this document, in part or in whole, is permitted without the consent of ROHM Co.,Ltd.

The content specified herein is subject to change for improvement without notice.

The content specified herein is for the purpose of introducing ROHM's products (hereinafter "Products"). If you wish to use any such Product, please be sure to refer to the specifications, which can be obtained from ROHM upon request.

Examples of application circuits, circuit constants and any other information contained herein illustrate the standard usage and operations of the Products. The peripheral conditions must be taken into account when designing circuits for mass production.

Great care was taken in ensuring the accuracy of the information specified in this document. However, should you incur any damage arising from any inaccuracy or misprint of such information, ROHM shall bear no responsibility for such damage.

The technical information specified herein is intended only to show the typical functions of and examples of application circuits for the Products. ROHM does not grant you, explicitly or implicitly, any license to use or exercise intellectual property or other rights held by ROHM and other parties. ROHM shall bear no responsibility whatsoever for any dispute arising from the use of such technical information.

The Products specified in this document are intended to be used with general-use electronic equipment or devices (such as audio visual equipment, office-automation equipment, communication devices, electronic appliances and amusement devices).

The Products specified in this document are not designed to be radiation tolerant.

While ROHM always makes efforts to enhance the quality and reliability of its Products, a Product may fail or malfunction for a variety of reasons.

Please be sure to implement in your equipment using the Products safety measures to guard against the possibility of physical injury, fire or any other damage caused in the event of the failure of any Product, such as derating, redundancy, fire control and fail-safe designs. ROHM shall bear no responsibility whatsoever for your use of any Product outside of the prescribed scope or not in accordance with the instruction manual.

The Products are not designed or manufactured to be used with any equipment, device or system which requires an extremely high level of reliability the failure or malfunction of which may result in a direct threat to human life or create a risk of human injury (such as a medical instrument, transportation equipment, aerospace machinery, nuclear-reactor controller, fuel-controller or other safety device). ROHM shall bear no responsibility in any way for use of any of the Products for the above special purposes. If a Product is intended to be used for any such special purpose, please contact a ROHM sales representative before purchasing.

If you intend to export or ship overseas any Product or technology specified herein that may be controlled under the Foreign Exchange and the Foreign Trade Law, you will be required to obtain a license or permit under the Law.



Thank you for your accessing to ROHM product informations.
More detail product informations and catalogs are available, please contact us.

ROHM Customer Support System

<http://www.rohm.com/contact/>