

## Package : VQFNxxxV6060/7070/8080 series

< A table of contents >

1. Structure and materials .....	1 / 5 page
2. Tape and Reel informations .....	1 / 5 ~ 3 / 5 page
3. Storage conditions .....	3 / 5 page
4. Marking lot number .....	3 / 5 page
5. Footprint dimensions .....	3 / 5 page
6. Recommended soldering .....	4 / 5 page

### 1. Structure and materials

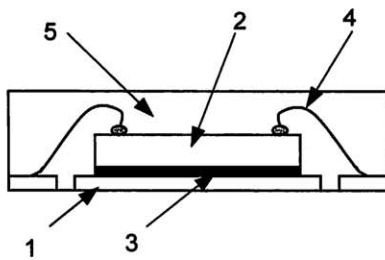

Fig. 1 Structure

No.	Item	Materials
1	Lead Frame	Cu-Alloy (External lead : Pb free solder plating)
2	Die	Silicon
3	Die Attach	Ag Paste
4	Wire	Au
5	Molding	Epoxy Resin

### 2. Tape and Reel information

#### 2.1. Packing specification

Tape	Embossed carrier tape
Quantity	See the table on page 5/5
Direction of feed	E2(See Fig. 2)

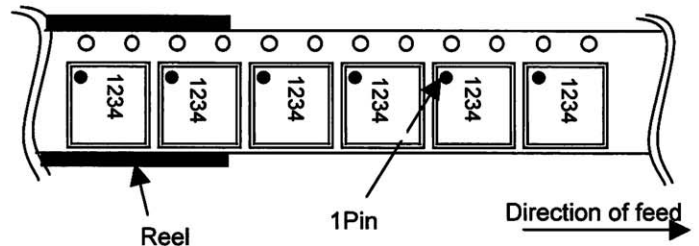

Fig. 2 Typical Tape and Reel configuration

#### 2.2. Tape and Reel specification

##### 2.2.1. Tape and reel dimensions (See the table on page 5/5)

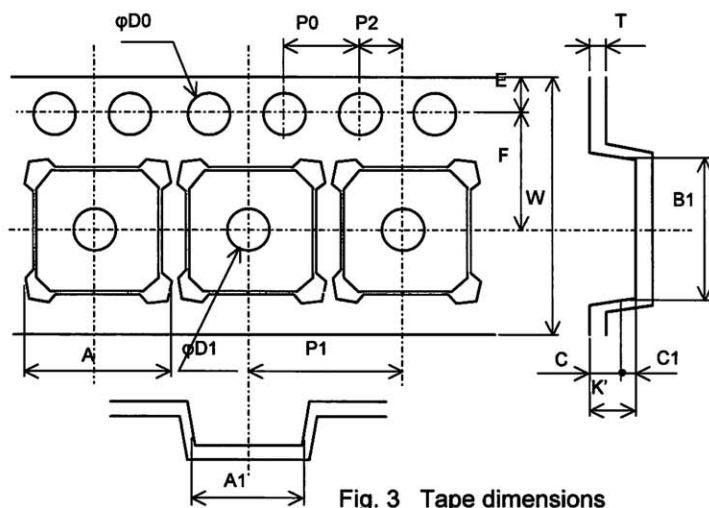

Fig. 3 Tape dimensions

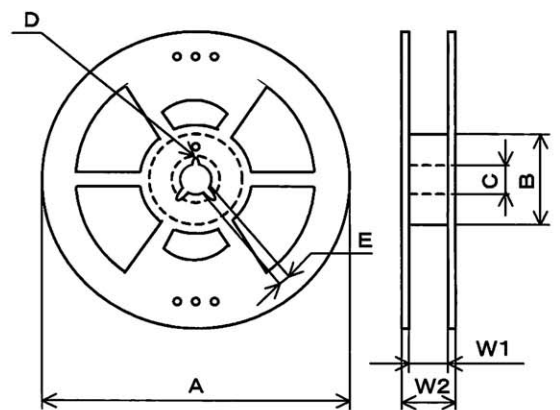

Fig. 4 Reel dimensions

2.3. Leader and Trailer

2.3.1. Leader

No component pockets are 25 pockets or more.

2.3.2. Trailer

No component pockets are 10 pockets or more.  
Tape is free from reel.

2.4. Label for Reel and Box

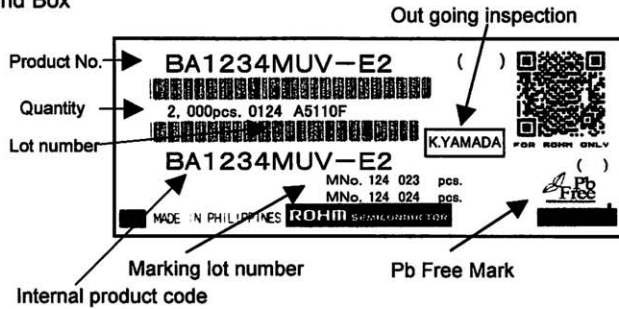

Fig. 5 Label example

2.5. Packing style

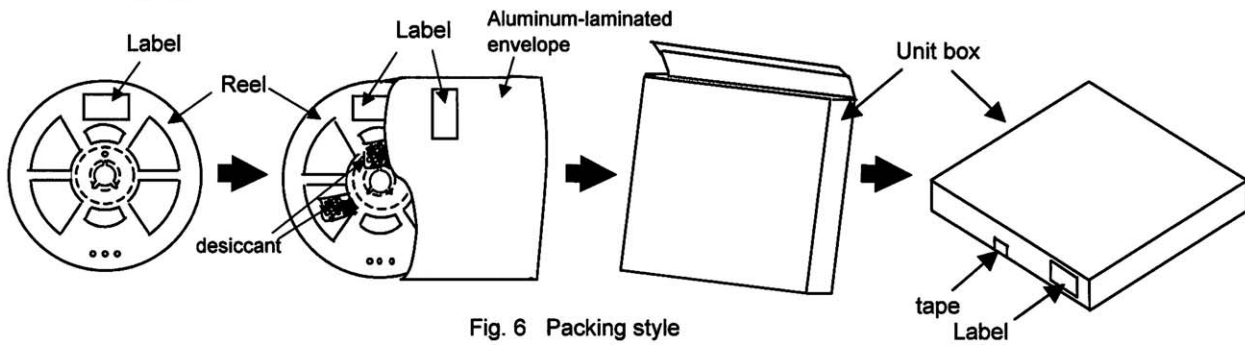
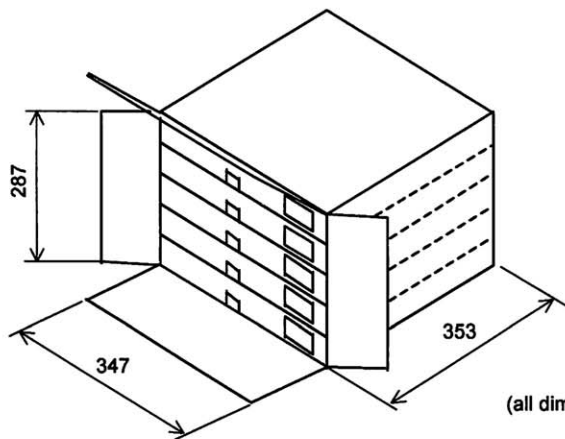

Fig. 6 Packing style

2.6. Shipping style

5 unit boxes or less per shipping box



(all dimensions in mm)

Fig. 7 Shipping box dimensions and Shipping style

2.7. Packing materials

Item	Material
Embossed carrier tape	PS
Cover tape	PET + PE
Reel	PS
Desiccant	Silicagel
Envelope	Aluminume-laminated
Unit box	Cardboard
Shipping box	Cardboard

2.8. Others

2.8.1. Peelback strength

Cover tape peelback strength is 0.2~0.7N.

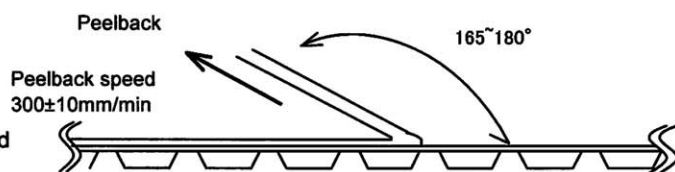

Fig. 8 Test method

2.8.8.Missing ICs

- (1)No consecutive dropouts.
- (2)A maximum 0.1% of specified number of products in each packing may be missing.

3.Storage conditions

3.1.Storage environment

Recommended storage conditions are as follows :

- Temperature :5to30°C
- Humidity :40to70 RH

3.2.Storage period

- Specified storage period :1year

3.3.Specified storage period until soldering

Dry process before mounting is necessary in the following two case.

- 1.After the package is opened , the product is left unused over 168 hours.
- 2.Before the package is opened , the product is left in the package unused over 1 year.

Please execute dry processing in a reel state with 60°C for 72 hours.

At this time, peelback strength of cover tape become 0.2N -0.9N.

Case of transferring to heatproof container such as trays, execute dry processing with 125°C for 24 hours.

In addition, the dry processing should be max, 2 times due to influence on the product's solderability.

4.Marking lot number

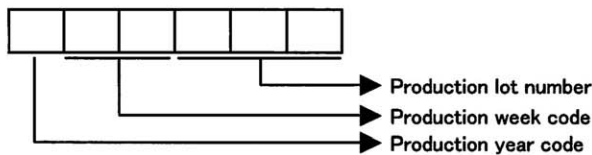

5.Footprint dimensions (Optimize footprint dimensions to the board design and soldering condition)

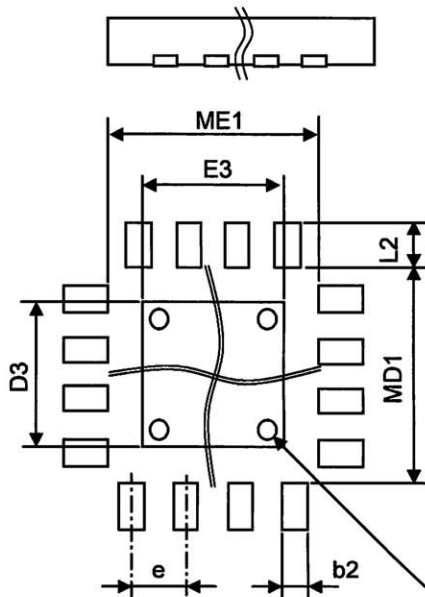

(all dimensions in mm)

Package	Land pitch e	Land			
		space		length	width
		MD1	ME1	L2	b 2
VQFN040V6060	0.50	5.00	5.00	0.80	0.27
VQFN048V7070	0.50	6.00	6.00	0.80	0.27
VQFN48AV7070	0.50	6.00	6.00	0.80	0.27
VQFN48SV7070	0.50	6.00	6.00	0.80	0.27
VQFN56AV8080	0.50	7.00	7.00	0.80	0.27

Package	Radiation land		Thermal Via	
	length	width	Pitch	Diameter
	D3	E3		
VQFN040V6060	4.00	4.00	1.2	φ0.300
VQFN048V7070	5.00	5.00	1.2	φ0.300
VQFN48AV7070	3.50	3.50	1.2	φ0.300
VQFN48SV7070	3.50	3.50	1.2	φ0.300
VQFN56AV8080	3.70	3.70	1.2	φ0.300

\*The lead toe and lead side fillet may not be achieved because of non-lead packages.

**6.Soldering conditions**

6.1.Recommended temperature profile for reflow

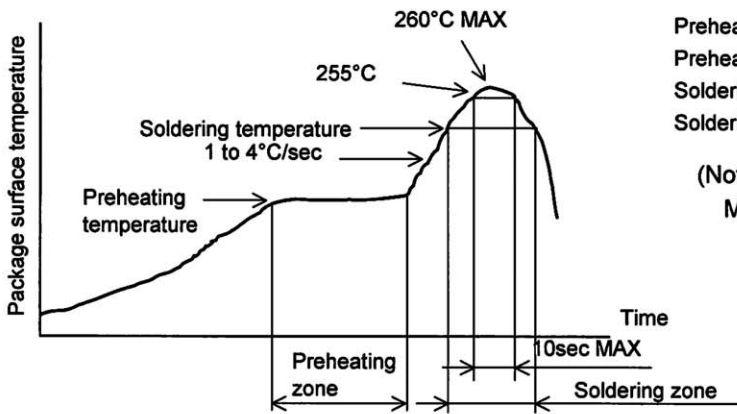

Preheating temperature ; 130°C to 190°C  
Preheating zone ; 120sec MAX  
Soldering temperature ; 220°C to 230°C  
Soldering zone ; 60sec MAX

(Notice)  
Maximum 2-times soldering

6.2.The wave soldering method is not supported.

6.3 Notice information of board mounting

Mounting on flexible film

Mounting on flexible film, film bend may occur lack of lead from package, usage of support board and under fill is recommended.

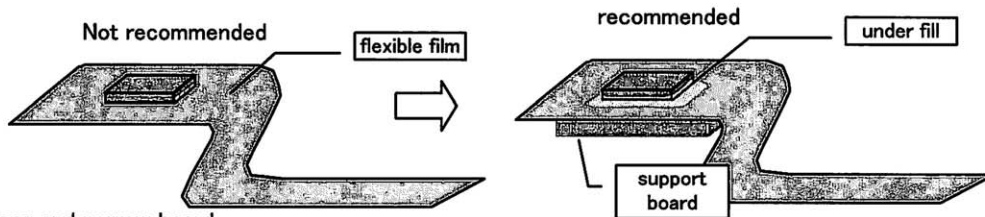

Mounting on long and narrow board

Mounting on long and narrow board, bending stress may occur a lack of lead from package, bending board direction and outer lead direction is recommended as drawing (vertically layout) and under fill usage is recommended.

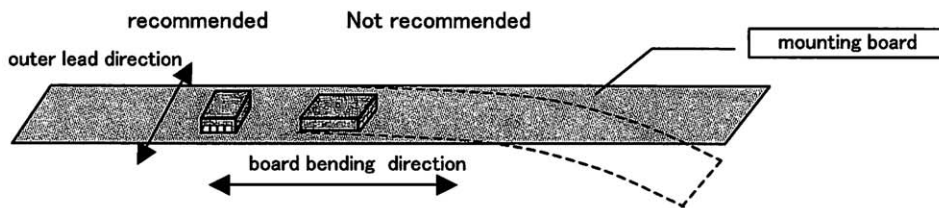

6.4 Rework by solering iron is not allowed or it may cause mold crack and terminal open.

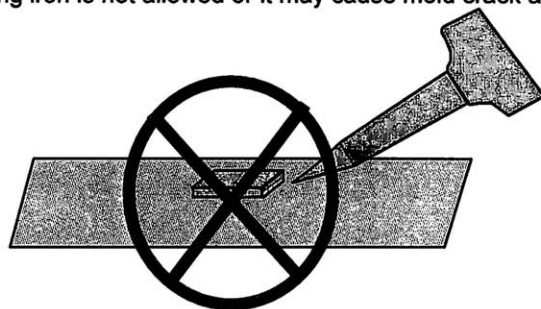

(Tape dimensions)

Package	Quantity	Tape dimensions (all dimensions in mm)													
	(pcs)	A1	B1	C	C1	D0	D1	E	F	K'	P0	P1	P2	T	W
VQFN040V6060	2000	6.2	6.2	(1.15)	(0.65)	φ1.5	φ1.5	1.75	5.5	1.80	4.0	8.0	2.0	0.3	12.0
VQFN048V7070	1500	7.2	7.2	(1.15)	(0.65)	φ1.5	φ1.5	1.75	7.5	1.80	4.0	12.0	2.0	0.3	16.0
VQFN48AV7070	1500	7.2	7.2	(1.15)	(0.65)	φ1.5	φ1.5	1.75	7.5	1.80	4.0	12.0	2.0	0.3	16.0
VQFN48SV7070	1500	7.2	7.2	(1.15)	(0.65)	φ1.5	φ1.5	1.75	7.5	1.80	4.0	12.0	2.0	0.3	16.0
VQFN56AV8080	1000	8.2	8.2	(1.15)	(0.65)	φ1.5	φ1.5	1.75	7.5	1.80	4.0	12.0	2.0	0.3	16.0
Tolerance		±0.05	±0.05	-	-	+0.1/0	±0.1	±0.1	±0.1	±0.1	±0.1	±0.1	±0.1	±0.05	±0.3

(Reel dimensions )

Package	Reel dimensions (all dimensions in mm)							Dehydrated weight
	A	B	C	D	E	W1	W2	(g)
VQFN040V6060	φ330	φ60	φ13.0	φ20.2	1.5	13.4	17.4	0.094
VQFN048V7070	φ330	φ60	φ13.0	φ20.2	1.5	17.4	21.4	0.130
VQFN48AV7070	φ330	φ60	φ13.0	φ20.2	1.5	17.4	21.4	0.130
VQFN48SV7070	φ330	φ60	φ13.0	φ20.2	1.5	17.4	21.4	0.130
VQFN56AV8080	φ330	φ80	φ13.0	φ20.2	1.5	17.4	21.4	0.141
Tolerance		-	+1.0/0	±0.2	MIN	MIN	+1.0/0	±1.0

## Notes

No copying or reproduction of this document, in part or in whole, is permitted without the consent of ROHM Co.,Ltd.

The content specified herein is subject to change for improvement without notice.

The content specified herein is for the purpose of introducing ROHM's products (hereinafter "Products"). If you wish to use any such Product, please be sure to refer to the specifications, which can be obtained from ROHM upon request.

Examples of application circuits, circuit constants and any other information contained herein illustrate the standard usage and operations of the Products. The peripheral conditions must be taken into account when designing circuits for mass production.

Great care was taken in ensuring the accuracy of the information specified in this document. However, should you incur any damage arising from any inaccuracy or misprint of such information, ROHM shall bear no responsibility for such damage.

The technical information specified herein is intended only to show the typical functions of and examples of application circuits for the Products. ROHM does not grant you, explicitly or implicitly, any license to use or exercise intellectual property or other rights held by ROHM and other parties. ROHM shall bear no responsibility whatsoever for any dispute arising from the use of such technical information.

The Products specified in this document are intended to be used with general-use electronic equipment or devices (such as audio visual equipment, office-automation equipment, communication devices, electronic appliances and amusement devices).

The Products specified in this document are not designed to be radiation tolerant.

While ROHM always makes efforts to enhance the quality and reliability of its Products, a Product may fail or malfunction for a variety of reasons.

Please be sure to implement in your equipment using the Products safety measures to guard against the possibility of physical injury, fire or any other damage caused in the event of the failure of any Product, such as derating, redundancy, fire control and fail-safe designs. ROHM shall bear no responsibility whatsoever for your use of any Product outside of the prescribed scope or not in accordance with the instruction manual.

The Products are not designed or manufactured to be used with any equipment, device or system which requires an extremely high level of reliability the failure or malfunction of which may result in a direct threat to human life or create a risk of human injury (such as a medical instrument, transportation equipment, aerospace machinery, nuclear-reactor controller, fuel-controller or other safety device). ROHM shall bear no responsibility in any way for use of any of the Products for the above special purposes. If a Product is intended to be used for any such special purpose, please contact a ROHM sales representative before purchasing.

If you intend to export or ship overseas any Product or technology specified herein that may be controlled under the Foreign Exchange and the Foreign Trade Law, you will be required to obtain a license or permit under the Law.



Thank you for your accessing to ROHM product informations.  
More detail product informations and catalogs are available, please contact us.

### ROHM Customer Support System

<http://www.rohm.com/contact/>