

## Package : VBGAXXXT series

(A table of contents)

1. Structure and materials .....	1/4 page
2. Tape and Reel information .....	1/4 to 3/4 page
3. Storage conditions .....	3/4 page
4. Marking lot number .....	3/4 page
5. Footprint dimensions .....	3/4 page
6. Soldering conditions .....	4/4 page

### 1. Structure and materials

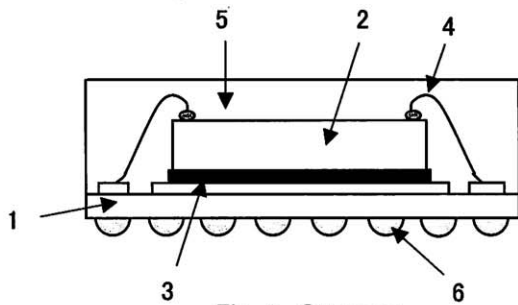

Fig. 1 Structure

No.	Item	Materials
1	Interposer	BT resin
2	Die	Silicon
3	Die Attach	Non-conductive Paste
4	Wire	Au
5	Molding	Epoxy Resin
6	External Lead	Solder Ball (Sn-3.0Ag-0.5Cu)

### 2. Tape and Reel information

#### 2.1. Packing specification

Tape	Embossed carrier tape with dry pack
Quantity	See the table on page 4/4
Direction of feed	E2 (See Fig. 2)

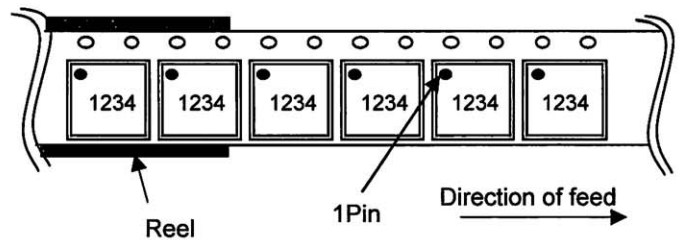

Fig. 2 Typical Tape and Reel configuration

#### 2.2. Tape and Reel specification

##### 2.2.1. Tape and reel dimensions (See the table on page 4/4)

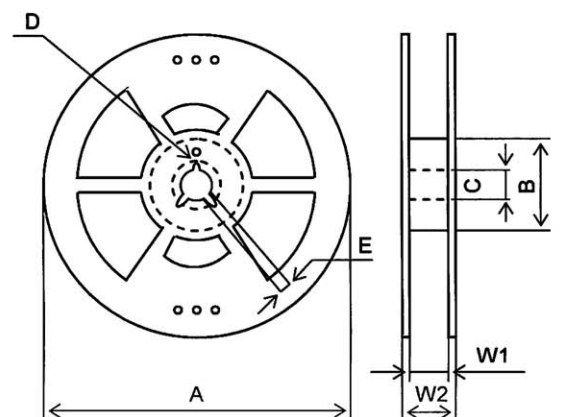
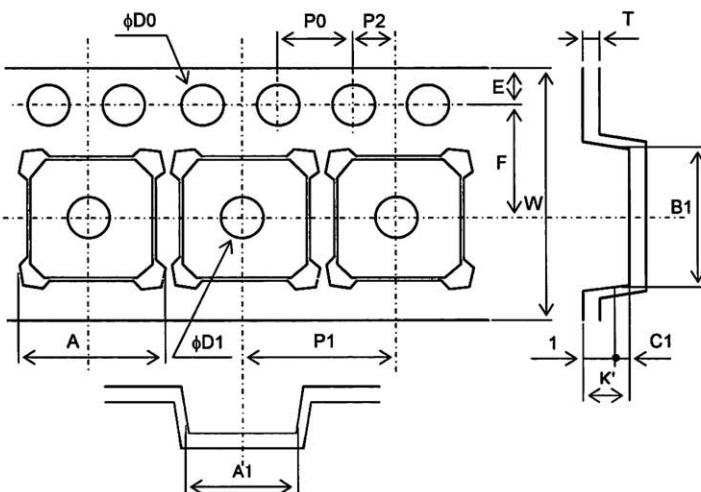

Fig. 4 Reel dimensions

2.3. Leader and Trailer

2.3.1. Leader

No component pockets are 25 pockets or more.

2.3.2. Trailer

No component pockets are 10 pockets or more.

Tape is free from reel.

2.4. Label for Reel and Box

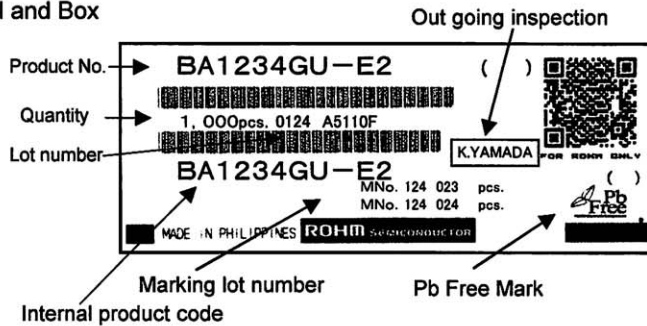

Fig. 5 Label example

2.5. Packing style

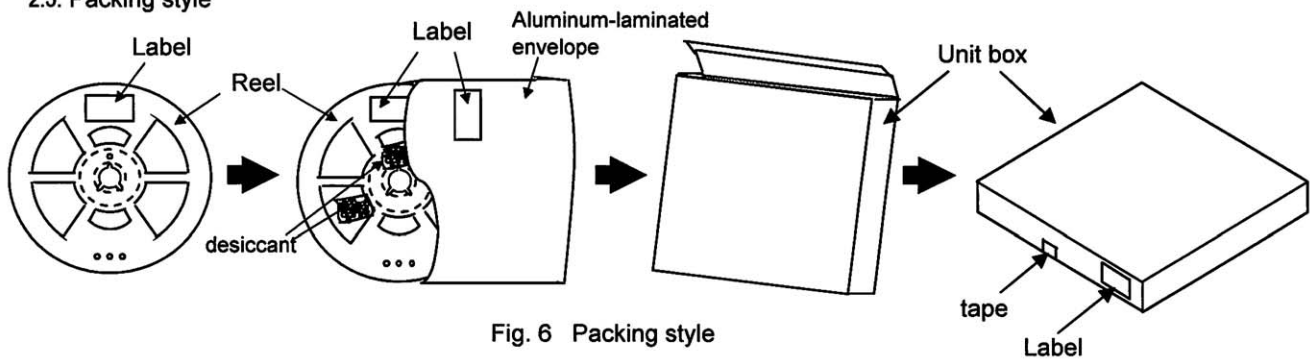
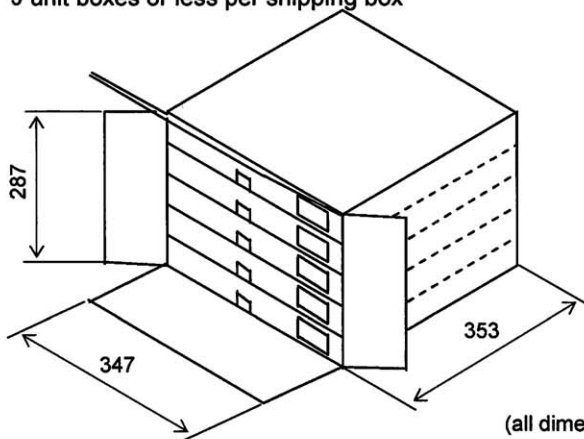

Fig. 6 Packing style

2.6. Shipping style

5 unit boxes or less per shipping box



(all dimensions in mm)

Fig. 7 Shipping box dimensions and Shipping style

2.7. Packing materials

Item	Material
Embossed carrier tape	PS
Cover tape	PET + PE
Reel	PS
Desiccant	Silicagel
Envelope	Aluminume-laminated
Unit box	Cardboard
Shipping box	Cardboard

2.8. Others

Cover tape peelback strength is 0.2 to 0.7N.

Fig. 8 Test method

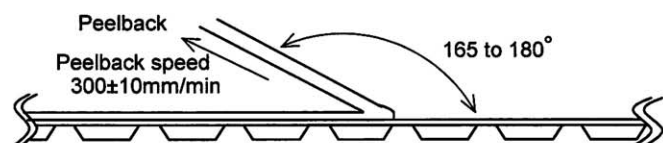

2.8.2. Missing ICs

- (1) No consecutive dropouts.
- (2) A maximum 0.1% of specified number of products in each packing may be missing.

3. Storage conditions

3.1. Storage environment

Recommended storage conditions are as follows :

- Temperature : 5 to 30°C
- Humidity : 40 to 70% RH

3.2. Storage period

-Specified storage period : 1 year

3.3. Specified storage period until soldering (except VBGA015T030)

Dry process before mounting is necessary in the following two cases.

1. After the package is opened, the product is left unused over 168 hours.
2. Before the package is opened, the product is left in the package unused over 1 year.

Please execute dry processing in a reel state with 60°C for 48 hours.

At this time, peelback strength of cover tape becomes 0.2N - 0.9N.

Case of transferring to heatproof container such as trays, execute dry processing with 125°C for 24 hours.

In addition, the dry processing should be max. 2 times due to influence on the product's solderability.

4. Marking lot number

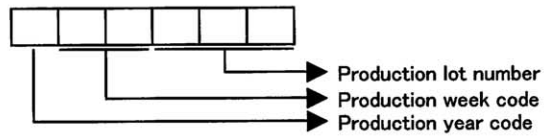
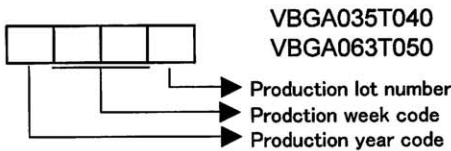

VBGA099T060  
 VBGA120T060  
 VBGA131T070  
 VBGA143T070  
 VBGA195T080  
 VBGA255T090  
 VBGA323T100

5. Footprint dimensions (Optimize footprint dimensions to the board design and soldering condition)

(all dimensions in mm)

VBGA035T040  
 VBGA063T050

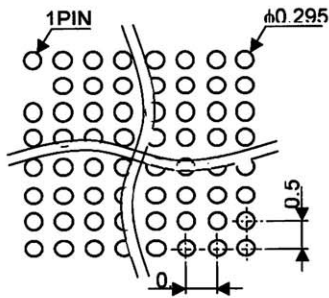

VBGA099T060  
 VBGA120T060  
 VBGA143T070  
 VBGA195T080  
 VBGA255T090  
 VBGA323T100

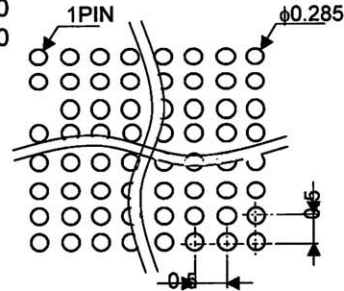

VBGA131T070

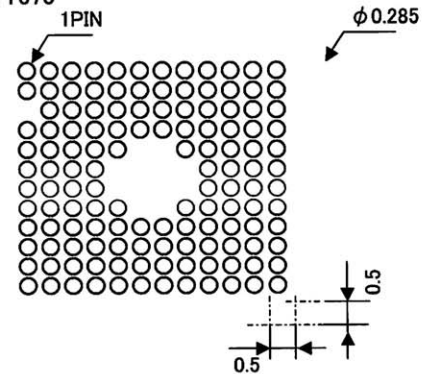

### 6.Soldering conditions

#### 6.1.Recommended temperature profile for reflow

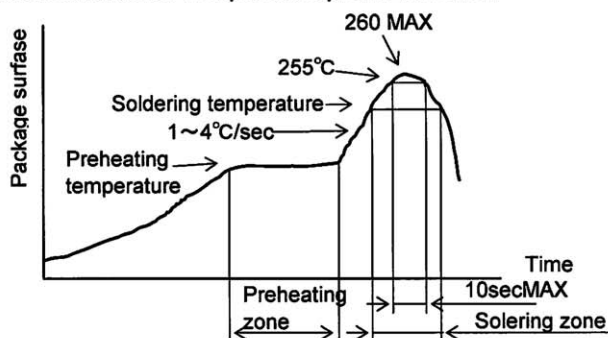

Preheating temperature ; 130°C ~ 190°C  
 Preheating zone ; 120sec MAX  
 Soldering temperature ; 220°C ~ 230°C  
 Soldering zone ; 60sec

(Notice)  
 Maximum 2-times soldering

#### 6.2.About mounting with Sn-Pb solder paste.

Mounting with Sn-Pb solder paste is not recommended because it has a possibility of reducing reliability to connect with Sn-3.0Ag-0.5Cu solder balls.

#### 6.3.The wave soldering method is not supported.

#### 6.4.Underfill

To apply underfill is recommended because it has a possibility of reducing reliability to connect by drop impact or bent stress of board.

(Tape dimensions)

Package	Quantity (pcs)	Tape dimensions (all dimensions in mm)													
		A1	B1	C	C1	D0	D1	E	F	K'	P0	P1	P2	T	W
VBGA015T030	4000	3.2	3.2	(1.15)	(0.65)	φ 1.5	φ 1.5	1.75	5.5	1.8	4.0	8.0	2.0	0.3	12.0
VBGA035T040	2500	4.2	4.2	(1.15)	(0.65)	φ 1.5	φ 1.5	1.75	5.5	1.8	4.0	8.0	2.0	0.3	12.0
VBGA063T050	2500	5.2	5.2	(1.15)	(0.65)	φ 1.5	φ 1.5	1.75	5.5	1.8	4.0	8.0	2.0	0.3	12.0
VBGA099T060	2000	6.2	6.2	(1.15)	(0.65)	φ 1.5	φ 1.5	1.75	5.5	1.8	4.0	8.0	2.0	0.3	12.0
VBGA120T060	2000	6.45	6.45	-	-	φ 1.5	φ 1.5	1.75	5.5	1.2	4.0	8.0	2.0	0.3	12.0
Toleranc		±0.05	±0.05	-	-	+0.1 -0	±0.1	±0.1	±0.05	±0.1	±0.1	±0.1	±0.05	±0.05	±0.2

Package	Quantity (pcs)	Tape dimensions (all dimensions in mm)													
		A1	B1	C	C1	D0	D1	E	F	K'	P0	P1	P2	T	W
VBGA131T070	1500	7.2	7.2	(1.15)	(0.65)	φ 1.5	φ 1.5	1.75	7.5	1.8	4.0	12.0	2.0	0.3	16.0
VBGA143T070	1500	7.2	7.2	(1.15)	(0.65)	φ 1.5	φ 1.5	1.75	7.5	1.8	4.0	12.0	2.0	0.3	16.0
VBGA195T080	1000	8.2	8.2	(1.15)	(0.65)	φ 1.5	φ 1.5	1.75	7.5	1.8	4.0	12.0	2.0	0.3	16.0
VBGA255T090	1000	9.2	9.2	(1.15)	(0.70)	φ 1.5	φ 1.5	1.75	7.5	1.85	4.0	12.0	2.0	0.3	16.0
VBGA323T100	1000	10.2	10.2	(1.15)	(0.70)	φ 1.5	φ 1.5	1.75	7.5	1.85	4.0	12.0	2.0	0.3	16.0
Toleranc		±0.05	±0.05	-	-	+0.1 -0	±0.1	±0.1	±0.1	±0.1	±0.1	±0.1	±0.1	±0.05	±0.3

(Reel dimensions)

(Dehydrated weight)

Package	Reel dimensions (all dimensions in mm)							Dehydrated weight dimensions in g
	A	B	C	D	E	W1	W2	
VBGA015T030	φ 330	50	13.0	20.2	1.5	13.4	17.4	0.02
VBGA035T040	φ 330	50	13.0	20.2	1.5	13.4	17.4	0.03
VBGA063T050	φ 330	50	13.0	20.2	1.5	13.4	17.4	0.05
VBGA099T060	φ 330	50	13.0	20.2	1.5	13.4	17.4	0.08
VBGA120T060	φ 330	50	13.0	20.2	1.5	13.4	17.4	0.08
VBGA131T070	φ 330	50	13.0	20.2	1.5	17.4	21.4	0.10
VBGA143T070	φ 330	50	13.0	20.2	1.5	17.4	21.4	0.10
VBGA195T080	φ 330	50	13.0	20.2	1.5	17.4	21.4	0.14
VBGA255T090	φ 330	50	13.0	20.2	1.5	17.4	21.4	0.18
VBGA323T100	φ 330	50	13.0	20.2	1.5	17.4	21.4	0.22
Tolerance	-	MIN	±0.2	MIN	MIN	±1.0	±1.0	



# Package Dimensions

VBGA035T040

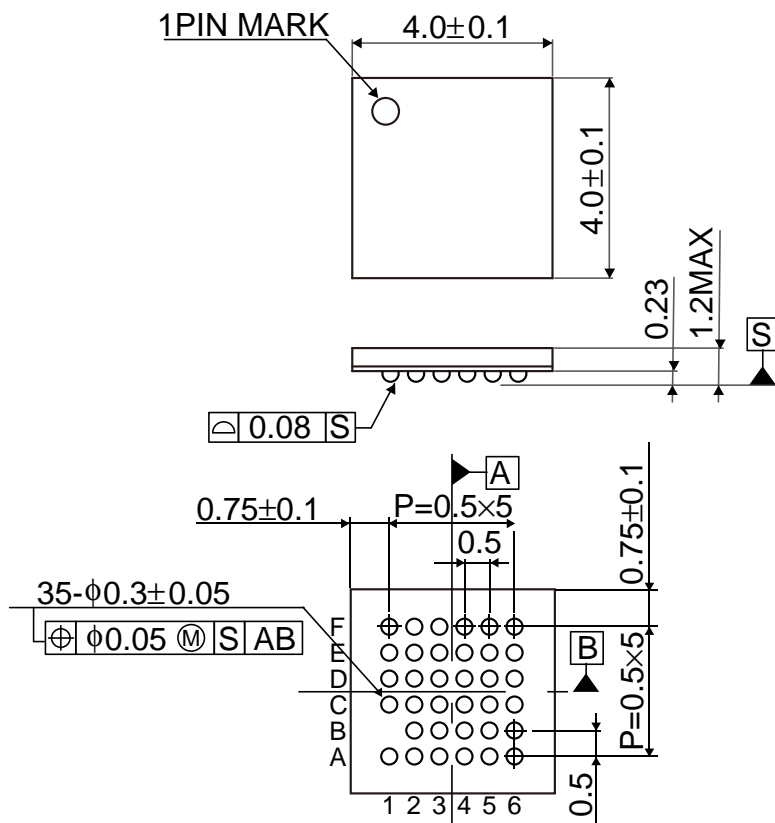

(Unit : mm)

# Package Dimensions

VBGA063T050

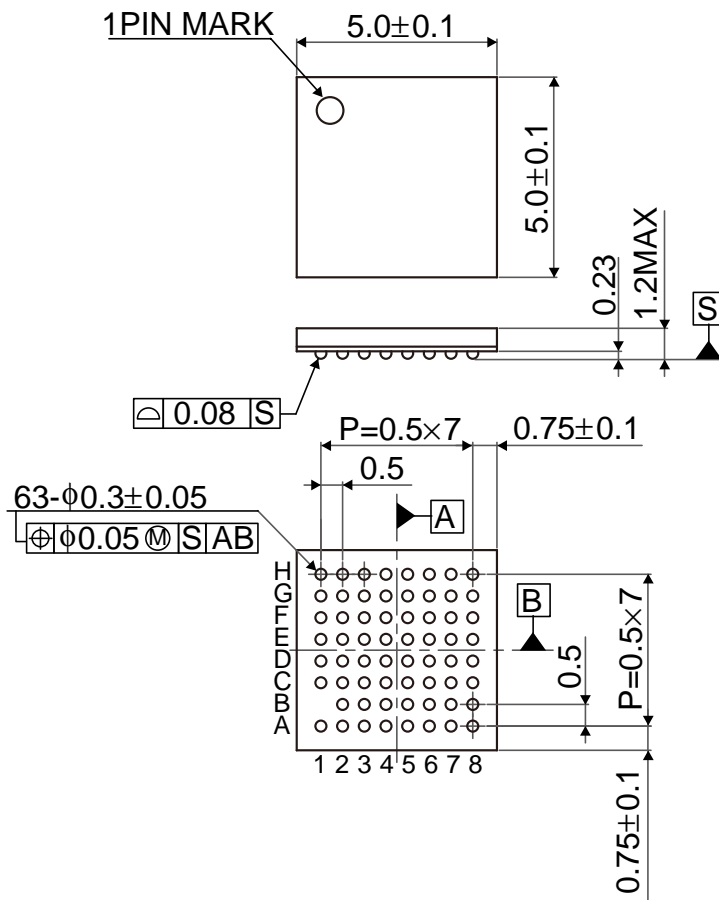

(Unit : mm)

# Package Dimensions

VBGA099T060

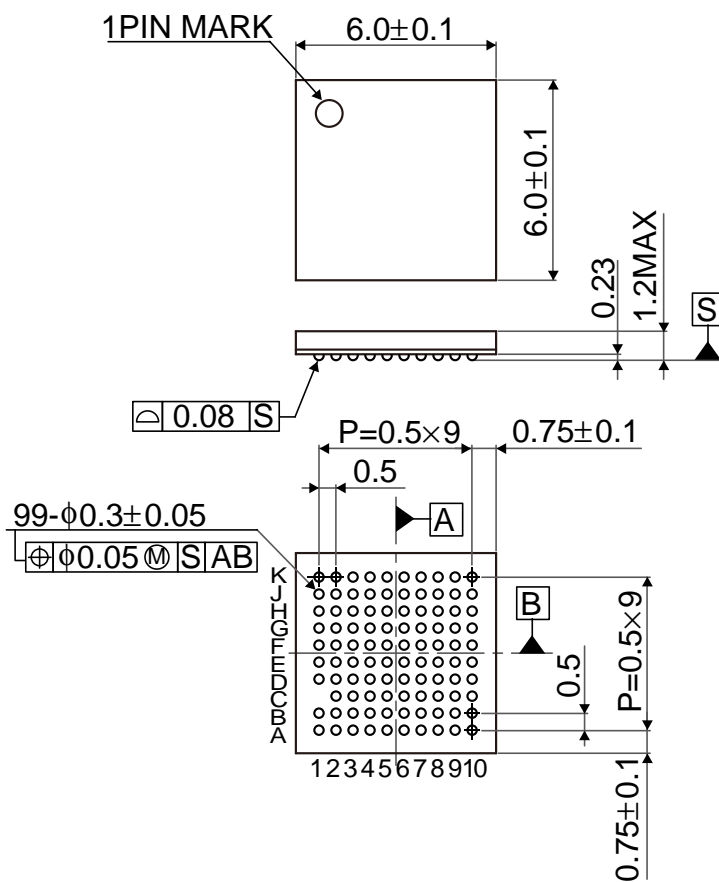

(Unit : mm)

# Package Dimensions

VBGA120T060

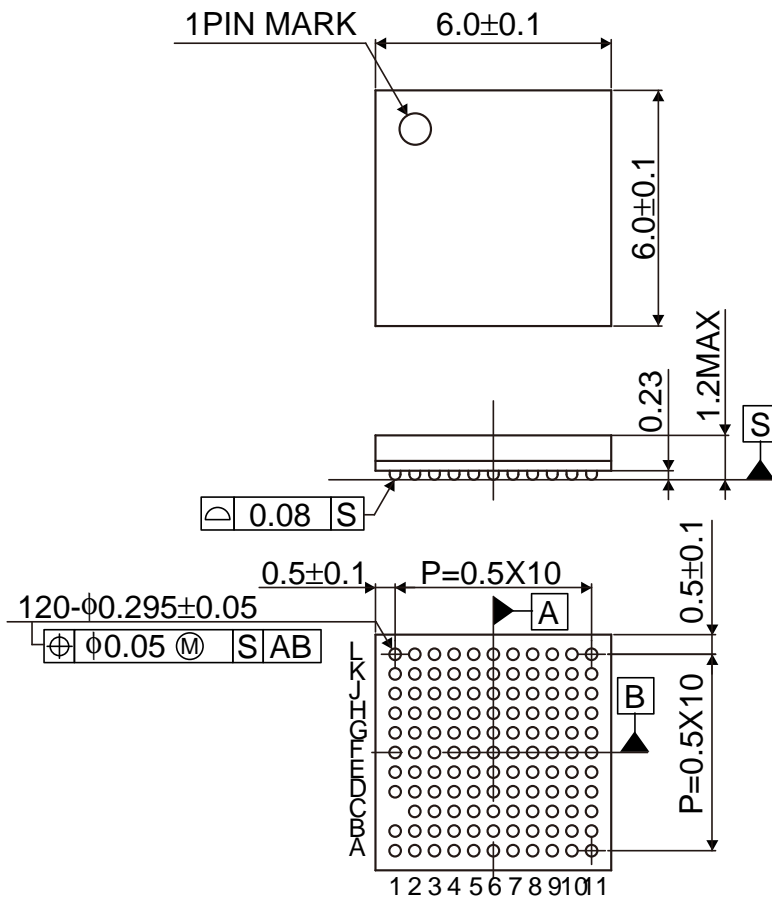

(Unit : mm)

# Package Dimensions

VBGA131T070

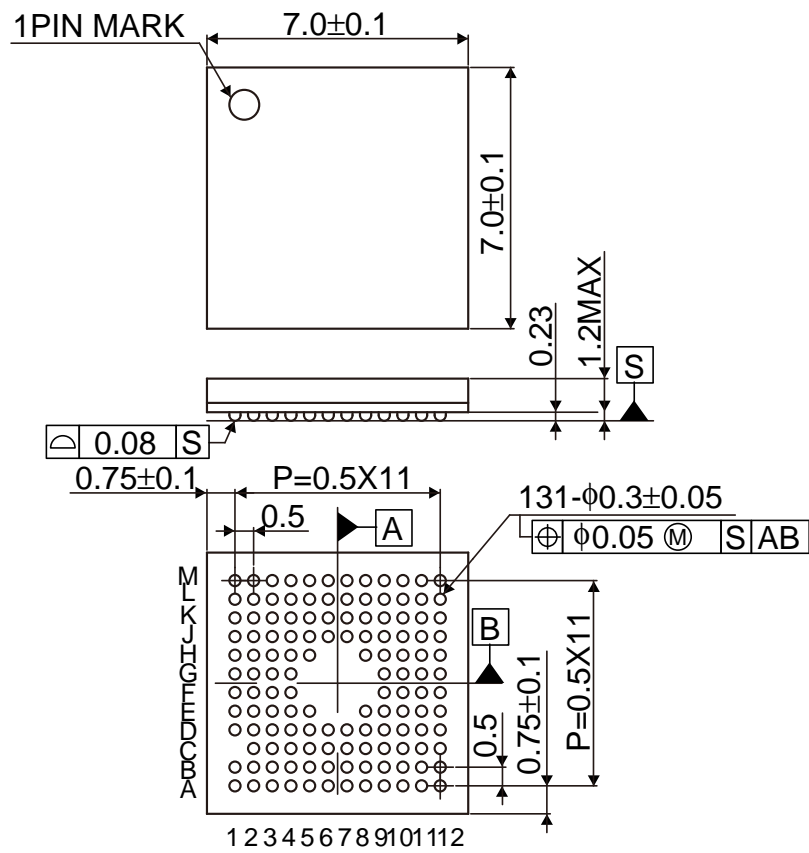

(Unit : mm)

# Package Dimensions

VBGA143T070

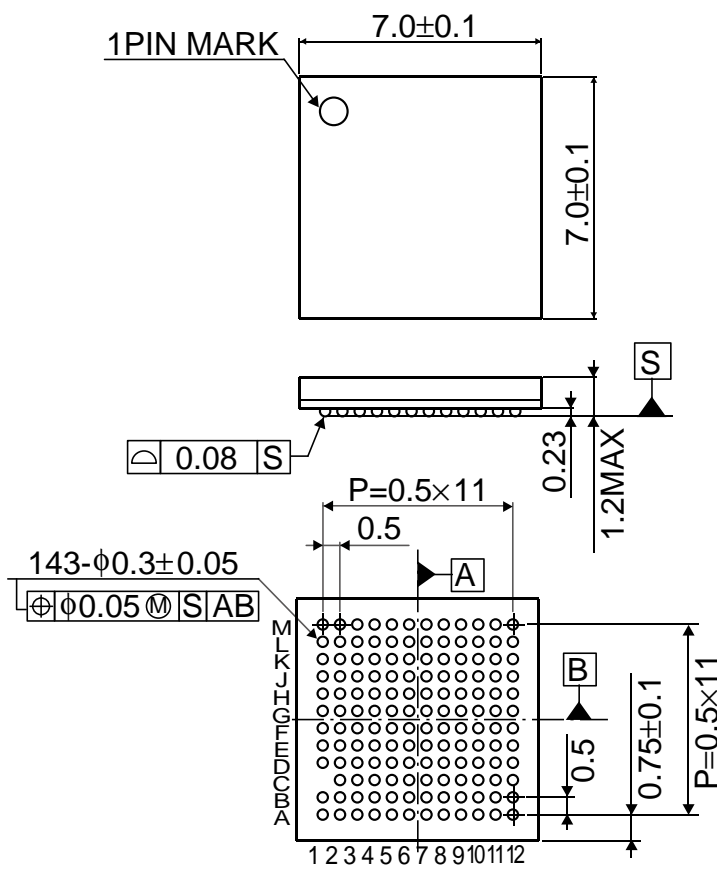

(Unit : mm)

# Package Dimensions

VBGA195T080

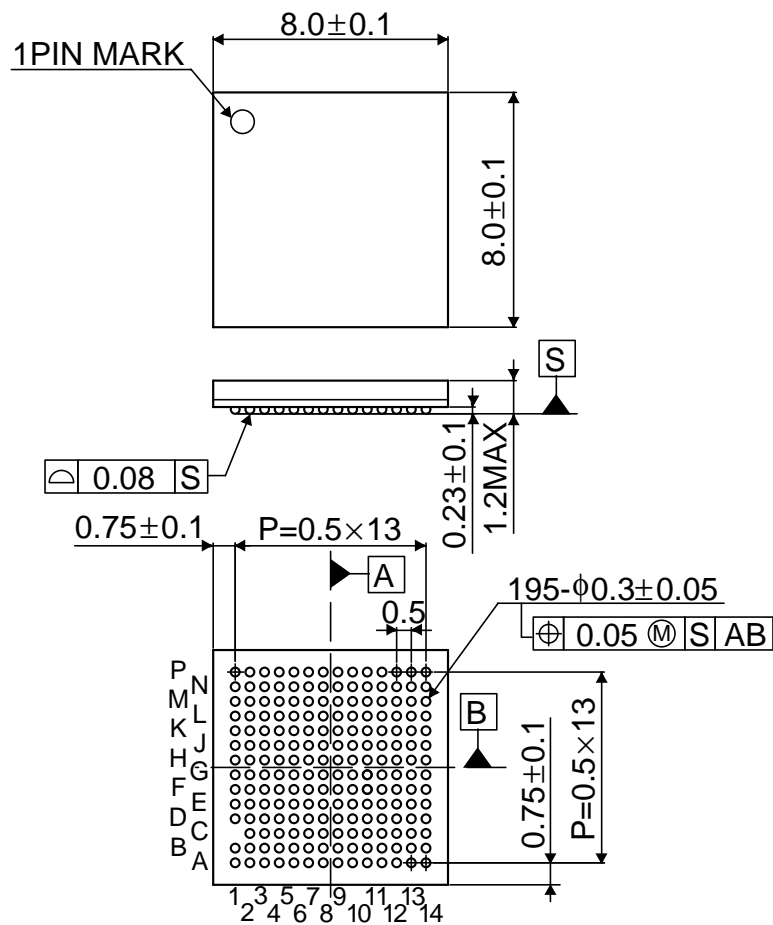

(Unit : mm)

# Package Dimensions

VBGA255T090

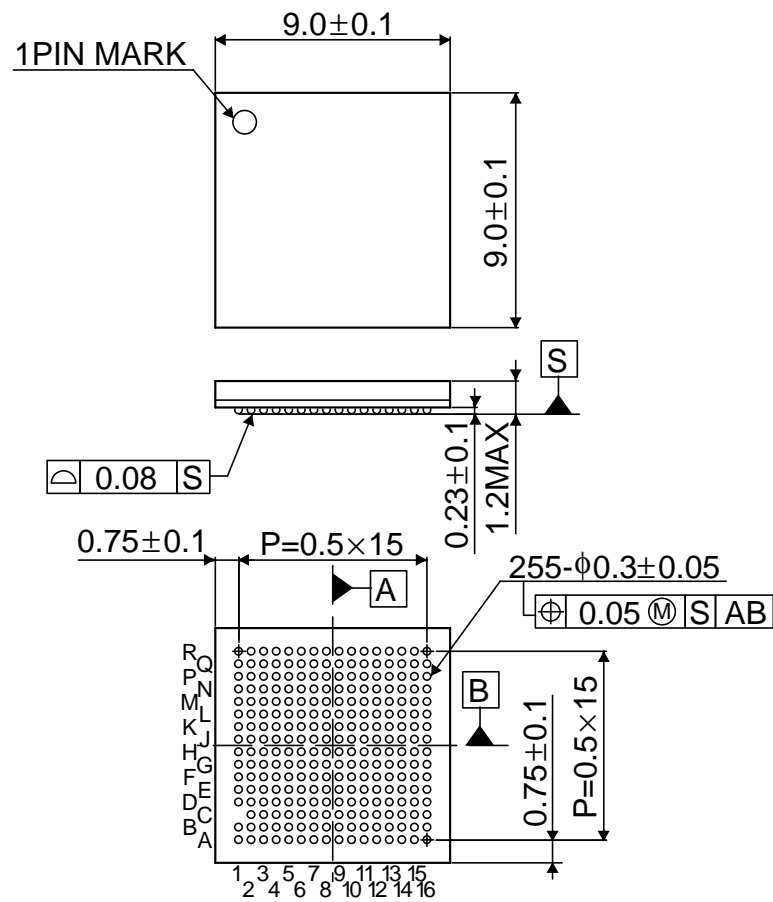

(Unit : mm)



## Notes

No copying or reproduction of this document, in part or in whole, is permitted without the consent of ROHM Co.,Ltd.

The content specified herein is subject to change for improvement without notice.

The content specified herein is for the purpose of introducing ROHM's products (hereinafter "Products"). If you wish to use any such Product, please be sure to refer to the specifications, which can be obtained from ROHM upon request.

Examples of application circuits, circuit constants and any other information contained herein illustrate the standard usage and operations of the Products. The peripheral conditions must be taken into account when designing circuits for mass production.

Great care was taken in ensuring the accuracy of the information specified in this document. However, should you incur any damage arising from any inaccuracy or misprint of such information, ROHM shall bear no responsibility for such damage.

The technical information specified herein is intended only to show the typical functions of and examples of application circuits for the Products. ROHM does not grant you, explicitly or implicitly, any license to use or exercise intellectual property or other rights held by ROHM and other parties. ROHM shall bear no responsibility whatsoever for any dispute arising from the use of such technical information.

The Products specified in this document are intended to be used with general-use electronic equipment or devices (such as audio visual equipment, office-automation equipment, communication devices, electronic appliances and amusement devices).

The Products specified in this document are not designed to be radiation tolerant.

While ROHM always makes efforts to enhance the quality and reliability of its Products, a Product may fail or malfunction for a variety of reasons.

Please be sure to implement in your equipment using the Products safety measures to guard against the possibility of physical injury, fire or any other damage caused in the event of the failure of any Product, such as derating, redundancy, fire control and fail-safe designs. ROHM shall bear no responsibility whatsoever for your use of any Product outside of the prescribed scope or not in accordance with the instruction manual.

The Products are not designed or manufactured to be used with any equipment, device or system which requires an extremely high level of reliability the failure or malfunction of which may result in a direct threat to human life or create a risk of human injury (such as a medical instrument, transportation equipment, aerospace machinery, nuclear-reactor controller, fuel-controller or other safety device). ROHM shall bear no responsibility in any way for use of any of the Products for the above special purposes. If a Product is intended to be used for any such special purpose, please contact a ROHM sales representative before purchasing.

If you intend to export or ship overseas any Product or technology specified herein that may be controlled under the Foreign Exchange and the Foreign Trade Law, you will be required to obtain a license or permit under the Law.



Thank you for your accessing to ROHM product informations.  
More detail product informations and catalogs are available, please contact us.

### ROHM Customer Support System

<http://www.rohm.com/contact/>