

System LED Drivers for Mobile Phones

13LEDs ALC* Flash and Illumination

(*ALC : Auto Luminous Control)

BD6086GU

No.11041EAT16

●Description

BD6086GU is a composite LED driver best-suited for mobile phone display.

With an analog illumination intensity sensor connected, this LED driver mounts an auto luminous control (ALC) function capable of automatically adjusting the backlight current depending on an ambient illumination intensity to reduce the set power consumption. With a key backlight driver mounted, this driver enables the ON/OFF setting to be made depending on the ambient illumination intensity. In addition, this driver realizes an eye-catching display through the use of two RGB LED drivers supporting a slope control function.

With two channels of variable output type regulators mounted, this driver can be used for LCD and camera. This driver eliminates the need for additional wirings on a flexible substrate through the GPIO mounted.

The DC/DC module adopts a charge pump system and rarely uses a coil. Furthermore, it employs a VCSP85H4 (4.5mm² 0.5mm pitch) chip size package for compaction and thinness.

●Futures

- 1) LED Driver (7ch) for LCD Backlight
 - Incorporates 4 channels for main settings and 3 channels optionally selectable for either independent control or main setting depending on register settings.
 - Provides a driver assigned for main settings with various functions such as an automatic current value adjustment function by an illumination intensity sensor, a slope control function against current value variation, an LED current value adjustment function for reflecting a setting value in a register through external pin synchronization and an LED current value adjustment function through external pin PWM input.
- 2) RGB LED driver (dual driver)
 - Incorporates a slope control function (capable of controlling dual drivers independently)
 - Capable of selecting (setting) a battery or DC/DC output module as a destination (register setting)
 - Capable of using one driver for GOP output mode (register setting)
- 3) Illumination intensity sensor interface
 - Incorporates various functions such as a sensor bias adjustment function, an ADC with an average filter, a gain/offset adjustment function and an LOG conversion function so that options can be increased for illumination intensity sensors (Photo Diode, Photo Transistor, Photo IC (Linear/LOG)).
 - Incorporates an auto gain switching function for suppressing an illumination intensity sensor current at high illumination intensity and improving sensitivity at low illumination intensity
 - Capable of customizing an LED current value according to a table setting.
- 4) Built-in regulator (2 channels)

• REG1 2.8V I _{max} =150mA	Low power consumption mode available
• REG2 1.5V/1.8V I _{max} =150mA	Low power consumption mode available
• REG1, REG2	Both can be controlled independently via external pins.
- 5) Charge pump system DC/DC
 - Supports an output voltage fixed mode function (3.9V/4.2V/4.5V/4.8V)
 - Mounts a soft start function, an overvoltage protection function (auto recovery type) and an overcurrent protection (auto recovery)
- 6) Key backlight controller
 - Capable of ON/OFF control depending on an ambient illumination intensity
 - Capable of adjusting key backlight brightness via MAX DUTY setting
 - Capable of making an fade-in/fade-out setting via PWM
- 7) Built-in general-purpose port (4 channels)
 - GPIO4ch
 - Permits the selection of a complementary or open drain for output.
- 8) Thermal shutdown
- 9) I²C BUS Fast mode support (max. 400 kHz)

* Radiation-proof is not designed.

* This Description is subject to change without a prior notice.

* This Description is not a delivery specification.

●Absolute Maximum Ratings (Ta=25 °C)

Parameter	Symbol	Limits	Unit
Maximum Applied voltage	VMAX	7	V
Power Dissipation	Pd	1900 Note1)	mW
Operating Temperature Range	Topr	-25 ~ +85	°C
Storage Temperature Range	Tstg	-55 ~ +150	°C

Note1) Power dissipation deleting is 15.2mW/ °C, when it's used in over 25 °C.
(It's deleting is on the board that is ROHM's standard)

●Operating conditions(VBAT ≥ VIO, VBAT ≥ VGPIO, Ta=-25~85°C)

Parameter	Symbol	Limits	Unit
VBAT input voltage	VBAT	2.7 ~ 5.5	V
VIO pin voltage	VIO	1.65 ~ 3.3	V
VGPIO pin voltage	VGPIO	1.65 ~ 3.3	V

●Electrical Characteristics(Unless otherwise specified, Ta=25°C, VBAT=3.6V, VIO=VGPIO=1.8V)

Parameter	Symbol	Limits			Unit	Condition
		Min.	Typ.	Max.		
【Circuit Current】						
VBAT Circuit current 1	IBAT1	-	0.1	3.0	μA	RESETB=0V, VIO=VGPIO=0V
VBAT Circuit current 2	IBAT2	-	0.5	3.0	μA	RESETB=0V, VIO=1.8V, VGPIO=0V
VBAT Circuit current 3	IBAT3	-	7.5	11.3	μA	REG1,REG2 Low consumption mode Io=0mA,VIO=1.8V, VGPIO=0V (control is rejistor setup)
VBAT Circuit current 4	IBAT4	-	110	165	μA	REG1,REG2 Nomal mode Io=0mA (control is rejistor setup)
VBAT Circuit current 5	IBAT5	-	61	65	mA	DC/DC x1mode, Io=60mA VBAT=4.0V
VBAT Circuit current 6	IBAT6	-	92	102	mA	DC/DC x1.5mode, Io=60mA VBAT=3.6V
VBAT Circuit current 7	IBAT7	-	123	140	mA	DC/DC x2mode, Io=60mA VBAT=2.7V
VBAT Circuit current 8	IBAT8	-	0.35	1.0	mA	ALC operating , Setup of ALCEN=1, AD cycle =0.5s Sensor current removes
【LED Driver】						
LED current Step (Current Setup)	ILEDSTPW1	128			step	WLED1~7
	ILEDSTPRGB1	128				RGB1 group, RGB2 group
LED current Step (At slope)	ILEDSTPW2	256			step	WLED1~7
	ILEDSTPRGB2	128				RGB1 group, RGB2 group
LED Maximum setup current 1	IMAX1	-	-	25.6	mA	WLED1~7, LED terminal voltage =1V
LED Maximum setup current 2	IMAX2	-	-	30.48	mA	RGB1 group, RGB2 group, LED terminal voltage =1V RGBISET=100kΩ
LED current accurate 1	ILED1	18	20	22	mA	WLED1~7, ILED=20mA setup, LED terminal voltage =1V
LED current accurate 2	ILED2	18	20	22	mA	RGB1 group, RGB2 group ILED=20mA, RGBISET =120kΩ LED terminal voltage =1V
LED current Matching	ILEDMT	-	5	10	%	WLED1~7, RGB1 group, RGB2 group
L Level output voltage	VOL2	-	-	0.2	V	RGB2 group GPO setup, IOL=1mA
LED OFF Leak current	ILKL	-	-	1.0	μA	

● Electrical Characteristics (Unless otherwise specified, Ta=25°C, VBAT=3.6V, VIO=VGPIO=1.8V)

Parameter	Symbol	Limits			Unit	Condition
		Min.	Typ.	Max.		
【DC/DC (Charge Pump)】						
Output voltage 1	VOCP1	-	Vf+0.2	Vf+0.25	V	Vf is forward direction of LED
Output voltage 2	VOCP2	3.705	3.9	4.095	V	At fixed voltage output mode, Io=60mA VBAT ≥ 3.2V
		3.99	4.2	4.41	V	
		4.275	4.5	4.725	V	
		4.56	4.8	5.04	V	
Load stability	Iout	-	-	255	mA	VBAT ≥ 3.2V, VOUT=4V
Oscillator frequency	fosc	0.8	1.0	1.2	MHz	
Over voltage protection detect voltage	OVP	-	6.0	6.5	V	
Over current protection detect current	OCP	-	250	375	mA	VOUT=0V
【Sensor interface】						
SBIAS Output voltage	VoS	2.85	3.0	3.15	V	Io=200μA
		2.47	2.6	2.73	V	Io=200μA
SBIAS Maximum Output Current	IomaxS	30	-	-	mA	Vo=2.6Vsetup
SBIAS Discharge resistor at OFF	ROFFS	-	1.0	1.5	kΩ	
SSENSinput voltage range	VISS	0	-	VoS × 255/256	V	
ADC resolution	ADRES	8			bit	
ADC integral calculus non-linearity	ADINL	-3	-	+3	LSB	
ADC differential calculus non-linearity	ADDNL	-1	-	+1	LSB	
SSENS Input impedance	RSENS	1	-	-	MΩ	
【REG1】						
Output voltage 1	Vo11	2.716	2.80	2.884	V	Io=150mA, VBAT ≥ 3.1V (Normal mode)
Output voltage 2	Vo12	2.668	2.80	2.912	V	Io=100μA, VBAT ≥ 3.1V (At low consumption mode)
I/O voltage difference	Vsat1	-	0.2	0.3	V	VBAT=2.5V, Io=150mA (Normal mode)
Load stability	ΔVo1	-	10	60	mV	Io=1 ~ 150mA (Normal mode)
Input stability	ΔVi1	-	10	60	mV	VBAT=3.2~5.5V, Io=150mA (Normal mode)
Ripple Rejection Ratio	RR1	40	50	-	dB	f=100Hz, Vin=200mVp-p (Normal mode)
Short circuit current limit	Ilim01	-	225	450	mA	Vo=0V (Normal mode)
Discharge resistor at OFF	ROFF1	-	1.0	1.5	kΩ	
【REG2】						
Output voltage 1	Vo21	1.74	1.80	1.86	V	Io=150mA (Normal mode)
		1.44	1.50	1.56	V	
Output voltage 2	Vo22	1.71	1.80	1.89	V	Io=100μA (At low consumption mode)
		1.425	1.50	1.575	V	
Load stability	ΔVo2	-	10	60	mV	Vo21=1.8V setup Io=1 ~ 150mA (Normal mode)
Input stability	ΔVi2	-	10	60	mV	Vo21=1.8V setup, VBAT=3.2~5.5V, Io=150mA (Normal mode)
Ripple Rejection Ratio	RR2	45	55	-	dB	Vo21=1.8V setup f=100Hz Vin=200mVp-p (Normal mode)
Short circuit current limit	Ilim02	-	225	450	mA	Vo=0V (Normal mode)
Discharge resistor at OFF	ROFF2	-	1.0	1.5	kΩ	

●Electrical Characteristics(Unless otherwise specified, Ta=25°C, VBAT=3.6V, VIO=VGPIO=1.8V)

Parameter	Symbol	Limits			Unit	Condition
		Min.	Typ.	Max.		
【SDA, SCL】 (I²C Interface)						
L level input voltage	VILI	-0.3	-	0.25 × VIO	V	
H level input voltage	VIHI	0.75 × VIO	-	VBAT +0.3	V	
Hysteresis of Schmitt trigger input	Vhysl	0.05 × VIO	-	-	V	
L level output voltage	VOLI	0	-	0.3	V	SDA pin, IOL=3 mA
Input current	linI	-10	-	10	μA	Input voltage = 0.1×VIO~0.9×VIO
【REG2VSEL】 (CMOS input pin)						
L level input voltage	VILV	-0.3	-	0.25 × VBAT	V	
H level input voltage	VIHV	0.75 × VBAT	-	VBAT +0.3	V	
Input current	linV	-10	-	10	μA	Input voltag= 0.1×VBAT~0.9×VBAT
【RGB1CNT, RGB2CNT】 (CMOS input pin with the Pull-down resistance)						
L level input voltage	VILL	-0.3	-	0.25 × VIO	V	
H level input voltage	VIHL	0.75 × VIO	-	VBAT +0.3	V	
Input current	linL	-	3.6	10	μA	Input voltag = 1.8V
【OSYNC, WPWMIN】 (NMOS input pin with the Pull-down resistance)						
L level input voltage	VILA	-0.3	-	0.3	V	
H level input voltage	VIHA	1.4	-	VBAT +0.3	V	
Input current	linA	-	3.6	10	μA	Input voltage = 1.8V
PWM Input frequency range	fwpwm	-	200	-	Hz	WPWMIN pin
【REG1EN, REG2EN, REG1MD, REG2MD】 (NMOS input pin with the Pull-down resistance)						
L level input voltage	VILC	-0.3	-	0.3	V	
H level input voltage	VIHC	1.4	-	VBAT +0.3	V	
Input current	linC	-	1	10	μA	Input voltage = 1.8V
【GPIO1~4】 (CMOS input and CMOS/ NMOS open drain output pin)						
L level input voltage	VOLG	-	-	0.2	V	IOL=1mA
H level input voltage	VOHG	VGPIO -0.2	-	-	V	At complementary output, IOH=1mA
L level input voltage	VILG	-0.3	-	0.25 × VGPIO	V	
H level input voltage	VIHG	0.75 × VGPIO	-	VGPIO +0.3	V	
Input current	linG	-10	-	10	μA	At setup of input mode Input voltage =0.1×VGPIO~0.9×VGPIO
Output leak Current	ILKG	-	3.3	10	μA	At open drain output, Vout=3.3V
Clock output frequency	fcko	25.00	31.25	37.50	kHz	At GPIO1 terminal, illumination standard clock on
【KBLT】 (Key backlight control CMOS/ NMOS open drain output pin)						
L level input voltage	VOLK	-	-	0.2	V	IOL=1mA
H level input voltage	VOHK	VGPIO -0.2	-	-	V	At complementary output, IOH=1mA
Output leak Current	ILKK	-	3.3	10	μA	At complementary output, VGPIO =3.3V
【GC1, GC2】 (Sensor gain control CMOS output pin)						
L level input voltage	VOLS	-	-	0.2	V	IOL=1mA
H level input voltage	VOHS	VoS -0.2	-	-	V	IOH=1mA
【INTB】 (NMOS open drain output pin)						
L level input voltage	VOLO	-	-	0.2	V	IOL=1mA
Output leak Current	ILKO	-	-	1.0	μA	Vout=3.3V

●Block Diagram / Application Circuit example

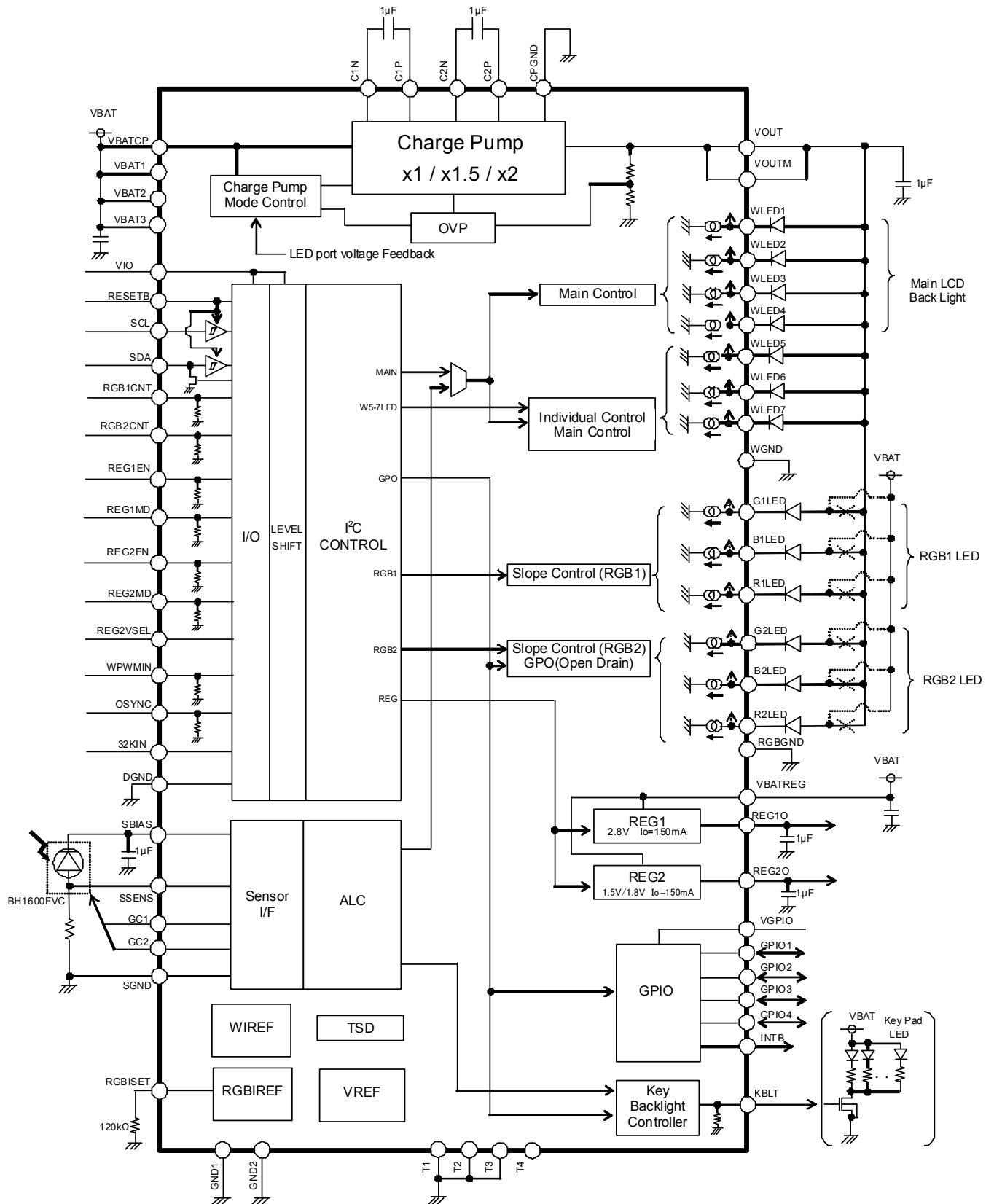

Block Diagram / Application Circuit example

●Pin Arrangement [Bottom View]

H	T4	REG20	VBATREG	REG10	VBAT2	VBAT3	SBIAS	T3
G	VGPIO	INTB	REG2EN	WPWMIN	OSYNC	GND2	SGND	SSENS
F	GND1	KBLT	GPIO1	REG1EN	GC1	GC2	RESETB	VIO
E	WLED7	WLED6	GPIO2	REG2VSEL	32KIN	SDA	SCL	DGND
D	WLED5	WLED4	GPIO3	(INDEX) 	RGB1CNT	RGB2CNT	VOUTM	VOUT
C	WGND	WLED3	GPIO4	RGBISET	REG1MD	REG2MD	C1P	C2P
B	WLED2	WLED1	R1LED	B1LED	R2LED	B2LED	C1N	VBATCP
A	T1	VBAT1	G1LED	RGBGND	G2LED	CPGND	C2N	T2
	1	2	3	4	5	6	7	8

●Outside size figure

VCSP85H4 CSP small Package

SIZE : 4.5mm × 4.5mm (Tolerance : ± 0.1mm each side) height 1.0mm max

Ball pitch : 0.5 mm

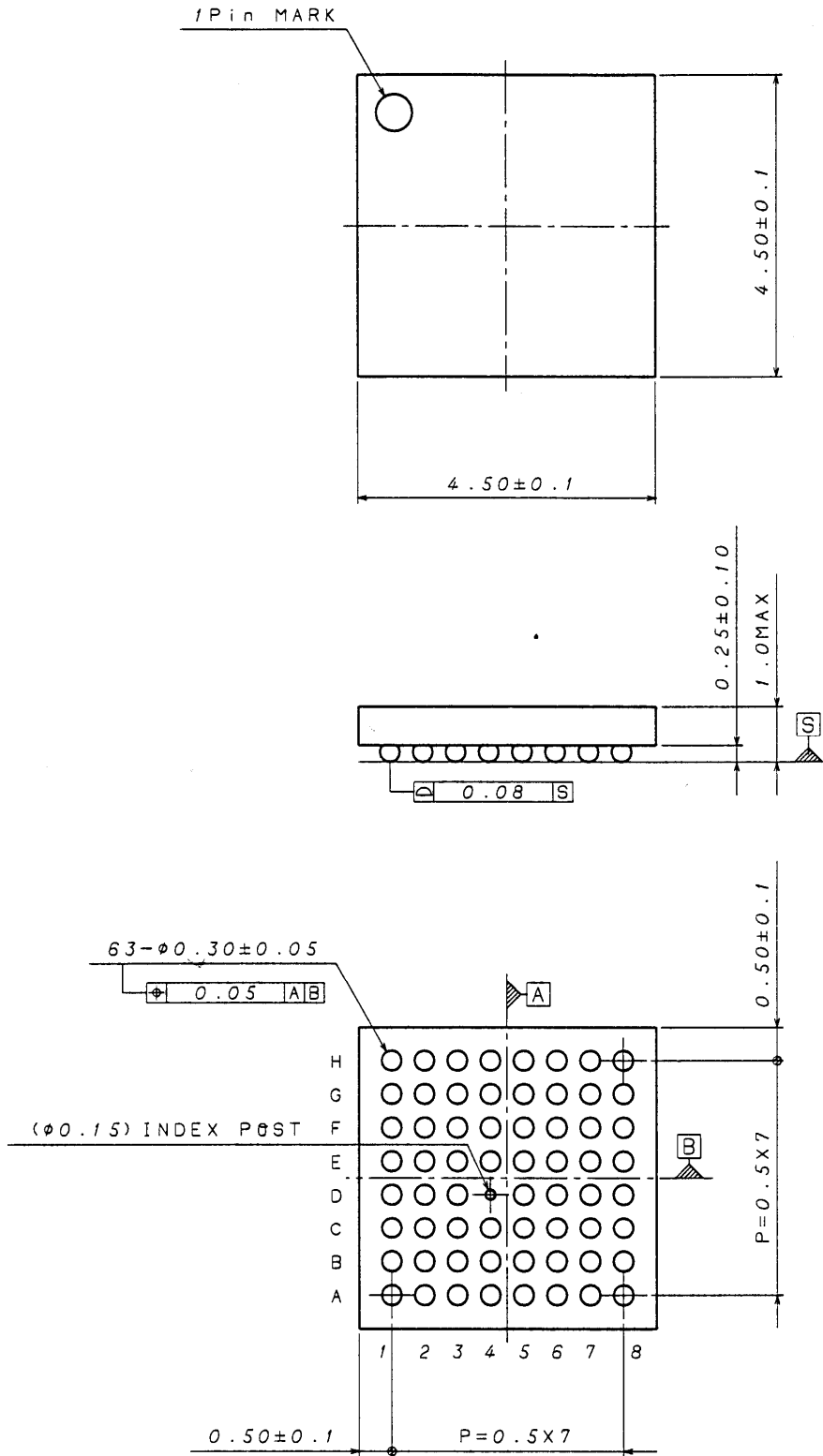

(Unit : mm)

● Pin Functions

No	Pin No.	Pin Name	I/O	Input Level		ESD Diode	Functions
				For Power	For Ground		
1	B8	VBATCP	-	-	GND	Battery is connected	A
2	A2	VBAT1	-	-	GND	Battery is connected	A
3	H5	VBAT2	-	-	GND	Battery is connected	A
4	H6	VBAT3	-	-	GND	Battery is connected	A
5	H3	VBATREG	-	-	GND	Battery is connected	A
6	A1	T1	-	VBAT	-	Test Pin (short to GND)	B
7	A8	T2	-	VBAT	GND	Test Pin (short to GND)	S
8	H8	T3	-	VBAT	GND	Test Pin (short to GND)	S
9	H1	T4	-	VBAT	GND	Test Pin (OPEN)	N
10	F8	VIO	-	VBAT	GND	I/O voltage source is connected	C
11	G1	VGPIO	-	VBAT	GND	GPIO voltage source is connected	C
12	F7	RESETB	I	VBAT	GND	Reset input (L: RESET, H: RESET cancel)	H
13	E6	SDA	I/O	VBAT	GND	I ² C data input	I
14	E7	SCL	I	VBAT	GND	I ² C clock input	H
15	A6	CPGND	-	VBAT	-	Ground	B
16	F1	GND1	-	VBAT	-	Ground	B
17	G6	GND2	-	VBAT	-	Ground	B
18	C1	WGND	-	VBAT	-	Ground	B
19	A4	RGBGND	-	VBAT	-	Ground	B
20	E8	DGND	-	VBAT	-	Ground	B
21	B7	C1N	I/O	VBAT	GND	Charge Pump capacitor is connected	F
22	C7	C1P	I/O	-	GND	Charge Pump capacitor is connected	A
23	A7	C2N	I/O	VBAT	GND	Charge Pump capacitor is connected	F
24	C8	C2P	I/O	-	GND	Charge Pump capacitor is connected	A
25	D8	VOUT	O	-	GND	Charge Pump output pin	A
26	D7	VOUTM	O	-	GND	Charge Pump output pin	A
27	C4	RGBISET	I	VBAT	GND	RGB LED standard current	O
28	H4	REG1O	O	VBAT	GND	REG1 output pin	Q
29	H2	REG2O	O	VBAT	GND	REG2 output pin	Q
30	B2	WLED1	I	-	GND	LCD Back Light LED is connected 1	E
31	B1	WLED2	I	-	GND	LCD Back Light LED is connected 2	E
32	C2	WLED3	I	-	GND	LCD Back Light LED is connected 3	E
33	D2	WLED4	I	-	GND	LCD Back Light LED is connected 4	E
34	D1	WLED5	I	-	GND	LCD Back Light LED is connected 5	E
35	E2	WLED6	I	-	GND	LCD Back Light LED is connected 6	E
36	E1	WLED7	I	-	GND	LCD Back Light LED is connected 7	E
37	B3	R1LED	I	-	GND	Red LED1 connected	E
38	A3	G1LED	I	-	GND	Green LED1 connected	E
39	B4	B1LED	I	-	GND	Blue LED1 connected	E
40	B5	R2LED	I	-	GND	Red LED2 connected	E
41	A5	G2LED	I	-	GND	Green LED2 connected	E
42	B6	B2LED	I	-	GND	Blue LED2 connected	E
43	D5	RGB1CNT	I	VBAT	GND	RGB1 LED external ON/OFF Synchronism(L : OFF, H : ON)*	J
44	D6	RGB2CNT	I	VBAT	GND	RGB2 LED external ON/OFF Synchronism(L : OFF, H : ON)*	J
45	F4	REG1EN	I	VBAT	GND	REG1 ON/OFF control Pin (L: OFF, H: ON)	L
46	G3	REG2EN	I	VBAT	GND	REG2 ON/OFF control Pin (L: OFF, H: ON)	L
47	H7	SBIAS	O	VBAT	GND	Bias output for the AmbientLight Sensor	Q
48	G8	SSENS	I	VBAT	GND	AmbientLight Sensor input	N
49	F5	GC1	O	VBAT	GND	AmbientLight Sensor gain control output 1	X
50	F6	GC2	O	VBAT	GND	AmbientLight Sensor gain control output 2	X
51	G5	OSYNC	I	VBAT	GND	Current offset external synchronization	L
52	G7	SGND	-	VBAT	-	Ground	B
53	F3	GPIO1	I/O	VBAT	GND	General purpose output port 1	V
54	E3	GPIO2	I/O	VBAT	GND	General purpose output port 2	V
55	D3	GPIO3	I/O	VBAT	GND	General purpose output port 3	V
56	C3	GPIO4	I/O	VBAT	GND	General purpose output port 4	V
57	F2	KBLT	O	VBAT	GND	Key back light control output	W
58	G2	INTB	O	VBAT	GND	General-purpose port interrupts, output pin	U
59	E5	32KIN	I	VBAT	GND	General-purpose port clock input pin	H
60	C5	REG1MD	I	VBAT	GND	REG1 mode changeover terminal (L : low consumption, H:Normal)	L
61	C6	REG2MD	I	VBAT	GND	REG2 mode changeover terminal (L : low consumption, H:Normal)	L
62	G4	WPWMIN	I	VBAT	GND	Back light outside pulse width modulation output pin (L : OFF and H: on) *	L
63	E4	REG2VSEL	I	VBAT	GND	REG2 output voltage switching (L : 1.8V and H:1.5V)	R

*A setup of a register is separately necessary to validate it.

●Equivalent circuit diagram

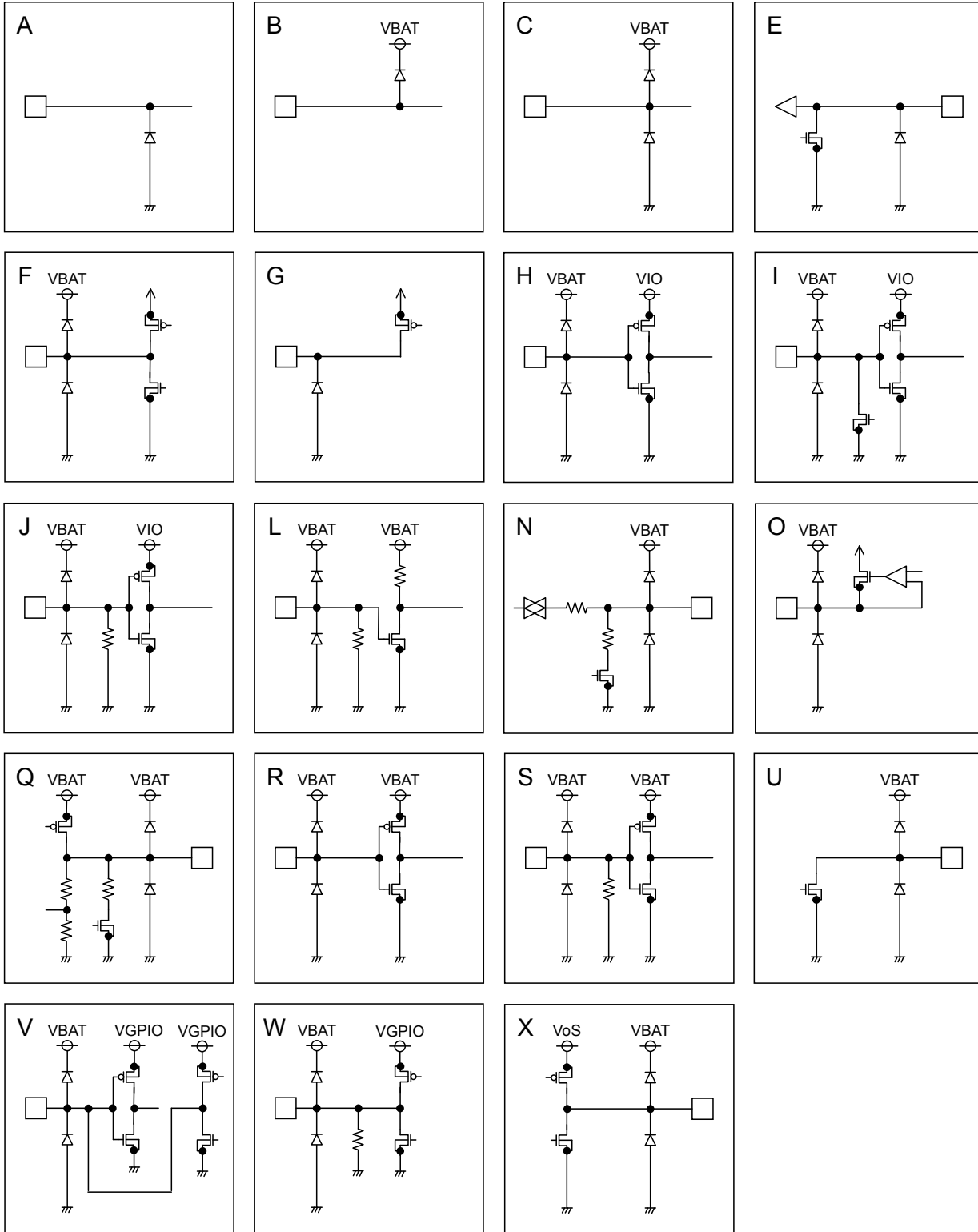

● I²C BUS format

The writing/reading operation is based on the I²C slave standard.

• Slave address

A7	A6	A5	A4	A3	A2	A1	R/W
1	1	1	0	1	1	0	1/0

• Bit Transfer

SCL transfers 1-bit data during H. SCL cannot change signal of SDA during H at the time of bit transfer. If SDA changes while SCL is H, START conditions or STOP conditions will occur and it will be interpreted as a control signal.

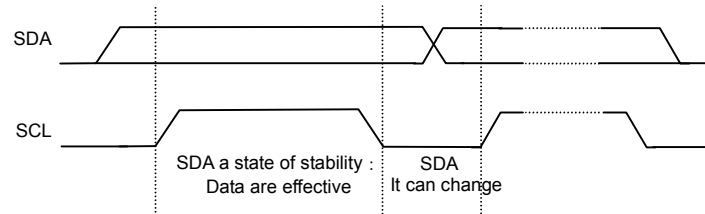

• START and STOP condition

When SDA and SCL are H, data is not transferred on the I²C- bus. This condition indicates, if SDA changes from H to L while SCL has been H, it will become START (S) conditions, and an access start, if SDA changes from L to H while SCL has been H, it will become STOP (P) conditions and an access end.

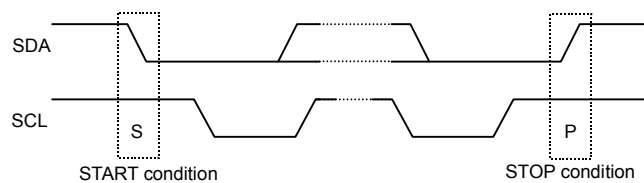

• Acknowledge

It transfers data 8 bits each after the occurrence of START condition. A transmitter opens SDA after transfer 8bits data, and a receiver returns the acknowledge signal by setting SDA to L.

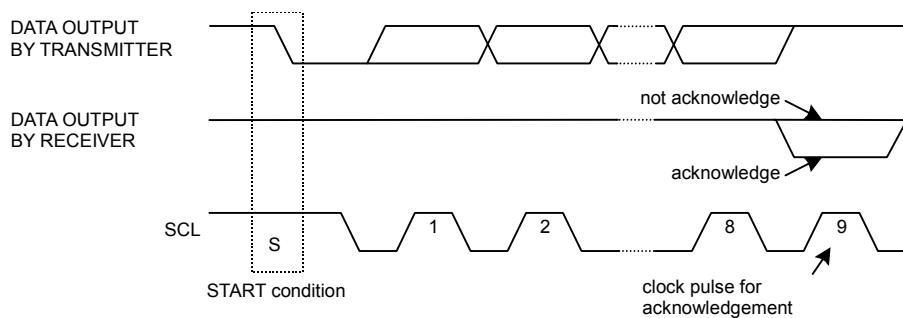

• Writing protocol

A register address is transferred by the next 1 byte that transferred the slave address and the write-in command. The 3rd byte writes data in the internal register written in by the 2nd byte, and after 4th byte or, the increment of register address is carried out automatically. However, when a register address turns into the last address, it is set to 00h by the next transmission. After the transmission end, the increment of the address is carried out.

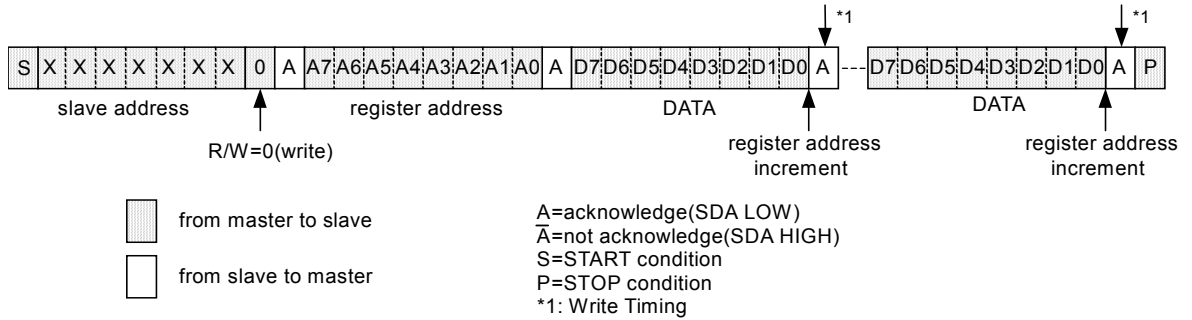

• Reading protocol

It reads from the next byte after writing a slave address and R/W bit. The register to read considers as the following address accessed at the end, and the data of the address that carried out the increment is read after it. If an address turns into the last address, the next byte will read out 00h. After the transmission end, the increment of the address is carried out.

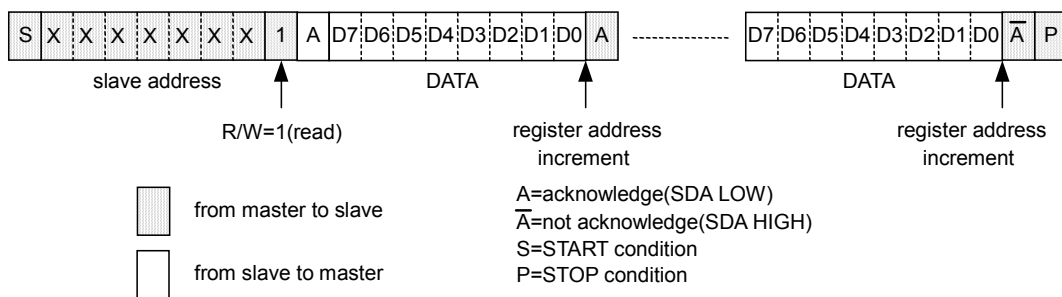

• Multiple reading protocols

After specifying an internal address, it reads by repeated START condition and changing the data transfer direction. The data of the address that carried out the increment is read after it. If an address turns into the last address, the next byte will read out 00h. After the transmission end, the increment of the address is carried out.

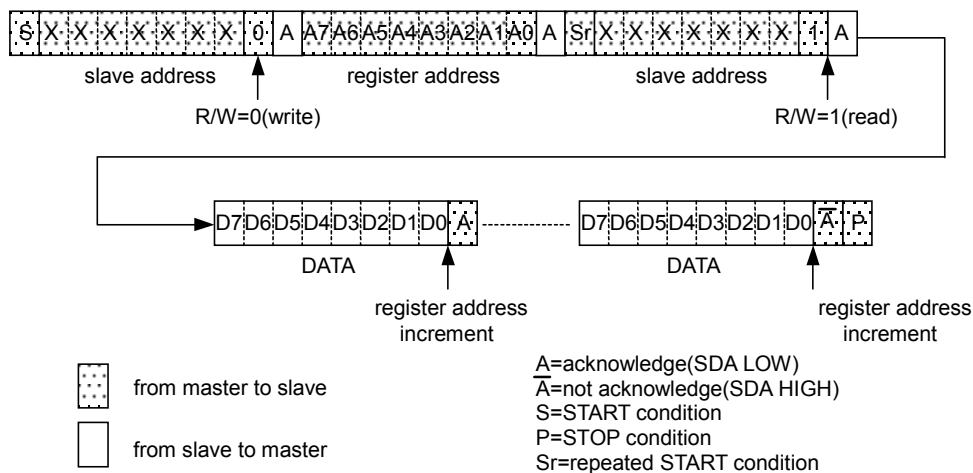

As for reading protocol and multiple reading protocols, please do \bar{A} (not acknowledge) after doing the final reading operation. It stops with read when ending by A (acknowledge), and SDA stops in the state of Low when the reading data of that time is 0. However, this state returns usually when SCL is moved, data is read, and \bar{A} (not acknowledge) is done.

●Timing diagram

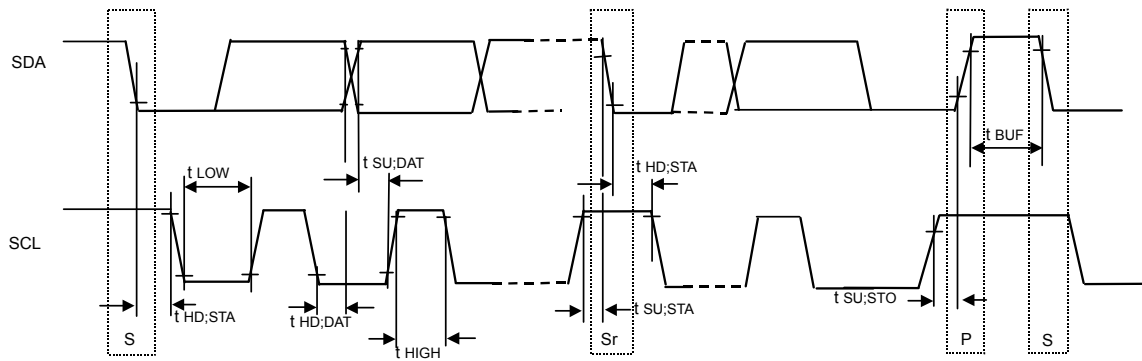

●Electrical Characteristics(Unless otherwise specified, Ta=25 °C, VBAT=3.6V, VIO=1.8V)

Parameter	Symbol	Standard-mode			Fast-mode			Unit
		Min.	Typ.	Max.	Min.	Typ.	Max.	
[I²C BUS format]								
SCL clock frequency	fSCL	0	-	100	0	-	400	kHz
LOW period of the SCL clock	tLOW	4.7	-	-	1.3	-	-	μs
HIGH period of the SCL clock	tHIGH	4.0	-	-	0.6	-	-	μs
Hold time (repeated) START condition After this period, the first clock is generated	tHD;STA	4.0	-	-	0.6	-	-	μs
Set-up time for a repeated START condition	tSU;STA	4.7	-	-	0.6	-	-	μs
Data hold time	tHD;DAT	0	-	3.45	0	-	0.9	μs
Data set-up time	tSU;DAT	250	-	-	100	-	-	ns
Set-up time for STOP condition	tSU;STO	4.0	-	-	0.6	-	-	μs
Bus free time between a STOP and START condition	tBUF	4.7	-	-	1.3	-	-	μs

● Register List

Address	W/R	Register data								Function
		D7	D6	D5	D4	D3	D2	D1	D0	
00h	W	VOUT(1)	VOUT(0)	DCDCMD	DCDCFON	-	-	-	SFTRST	Soft Reset DC/DC driver function
01h	W	RGB2PW(1)	RGB2PW(0)	RGB1PW(1)	RGB1PW(0)	W7MD	W6MD	W5MD	MLEDMD	LED driver function
02h	W	W7EN	W6EN	W5EN	MLEDEN	REG2CNT	REG2ON	REG1CNT	REG1ON	Power control
03h	W	-	IMLED(6)	IMLED(5)	IMLED(4)	IMLED(3)	IMLED(2)	IMLED(1)	IMLED(0)	Main current
04h	W	-	IW5(6)	IW5(5)	IW5(4)	IW5(3)	IW5(2)	IW5(1)	IW5(0)	WLED5 current
05h	W	-	IW6(6)	IW6(5)	IW6(4)	IW6(3)	IW6(2)	IW6(1)	IW6(0)	WLED6 current
06h	W	-	IW7(6)	IW7(5)	IW7(4)	IW7(3)	IW7(2)	IW7(1)	IW7(0)	WLED7 current
07h	W	THL (3)	THL (2)	THL (1)	THL (0)	TLH (3)	TLH (2)	TLH (1)	TLH (0)	Main current transition
08h	W	-	-	IOFS(5)	IOFS(4)	IOFS(3)	IOFS(2)	IOFS(1)	IOFS(0)	Main current offset
09h	W	WPWMEN	SBIASON	-	OSYNCEN	-	OSSLP(2)	OSSLP(1)	OSSLP(0)	OSYNC current transition
0Ah	R	-	IALED(6)	IALED(5)	IALED(4)	IALED(3)	IALED(2)	IALED(1)	IALED(0)	Main current data read
0Bh	W	ADCYC (1)	ADCYC (0)	GAIN (1)	GAIN(0)	STYPE	VSB	MDCIR	ALCEN	Measurement mode setup
0Ch	W	SOFS (3)	SOFS (2)	SOFS (1)	SOFS (0)	SGAIN (3)	SGAIN (2)	SGAIN (1)	SGAIN (0)	Measurement data adjustment
0Dh	R	-	-	-	-	AMB (3)	AMB (2)	AMB (1)	AMB (0)	Brightness data output
0Eh	W	-	IU0 (6)	IU0 (5)	IU0 (4)	IU0 (3)	IU0 (2)	IU0 (1)	IU0 (0)	Brightness 0 : LED current setup
0Fh	W	-	IU1 (6)	IU1 (5)	IU1 (4)	IU1 (3)	IU1 (2)	IU1 (1)	IU1 (0)	Brightness 1 : LED current setup
10h	W	-	IU2 (6)	IU2 (5)	IU2 (4)	IU2 (3)	IU2 (2)	IU2 (1)	IU2 (0)	Brightness 2 : LED current setup
11h	W	-	IU3 (6)	IU3 (5)	IU3 (4)	IU3 (3)	IU3 (2)	IU3 (1)	IU3 (0)	Brightness 3 : LED current setup
12h	W	-	IU4 (6)	IU4 (5)	IU4 (4)	IU4 (3)	IU4 (2)	IU4 (1)	IU4 (0)	Brightness 4 : LED current setup
13h	W	-	IU5 (6)	IU5 (5)	IU5 (4)	IU5 (3)	IU5 (2)	IU5 (1)	IU5 (0)	Brightness 5 : LED current setup
14h	W	-	IU6 (6)	IU6 (5)	IU6 (4)	IU6 (3)	IU6 (2)	IU6 (1)	IU6 (0)	Brightness 6 : LED current setup
15h	W	-	IU7 (6)	IU7 (5)	IU7 (4)	IU7 (3)	IU7 (2)	IU7 (1)	IU7 (0)	Brightness 7 : LED current setup
16h	W	-	IU8 (6)	IU8 (5)	IU8 (4)	IU8 (3)	IU8 (2)	IU8 (1)	IU8 (0)	Brightness 8 : LED current setup
17h	W	-	IU9 (6)	IU9 (5)	IU9 (4)	IU9 (3)	IU9 (2)	IU9 (1)	IU9 (0)	Brightness 9 : LED current setup
18h	W	-	IUA (6)	IUA (5)	IUA (4)	IUA (3)	IUA (2)	IUA (1)	IUA (0)	Brightness A : LED current setup
19h	W	-	IUB (6)	IUB (5)	IUB (4)	IUB (3)	IUB (2)	IUB (1)	IUB (0)	Brightness B : LED current setup
1Ah	W	-	IUC (6)	IUC (5)	IUC (4)	IUC (3)	IUC (2)	IUC (1)	IUC (0)	Brightness C : LED current setup
1Bh	W	-	IUD (6)	IUD (5)	IUD (4)	IUD (3)	IUD (2)	IUD (1)	IUD (0)	Brightness D : LED current setup
1Ch	W	-	IUE (6)	IUE (5)	IUE (4)	IUE (3)	IUE (2)	IUE (1)	IUE (0)	Brightness E : LED current setup
1Dh	W	-	IUF (6)	IUF (5)	IUF (4)	IUF (3)	IUF (2)	IUF (1)	IUF (0)	Brightness F : LED current setup
1Eh	W	-	-	KBSLP(1)	KBSLP(0)	MDTY(3)	MDTY(2)	MDTY(1)	MDTY(0)	Key driver control
1Fh	W	-	-	CHYS (1)	CHYS (0)	CTH (3)	CTH (2)	CTH (1)	CTH (0)	Key driver 2 Value judging control setup
20h	W	B2GPO	G2GPO	R2GPO	KBFIX	GP4DIR	GP3DIR	GP2DIR	GP1DIR	GPIO Input/output setup
21h	W	GPO1OSC	-	-	KBOD	GPO4OD	GPO3OD	GPO2OD	GPO1OD	GPIO output mode setup
22h	W	B2LV	G2LV	R2LV	-	GPO4LV	GPO3LV	GPO2LV	GPO1LV	GPIO output data setup
23h	W	GPCLR	-	-	-	GP4MSK	GP3MSK	GP2MSK	GP1MSK	GPIO Interrupt mask setup
24h	R	GP4INT	GP3INT	GP2INT	GP1INT	GP4DAT	GP3DAT	GP2DAT	GP1DAT	GPIO Interruption factor read-out GPIO data read-out

Input "0" for "-".

Vacancy address may be use for test.

Prohibit to accessing the address that isn't mentioned and the register for test.

Address	W/R	Register data								Function
		D7	D6	D5	D4	D3	D2	D1	D0	
25h	W	-	RGB2MEL	RGB2OS	RGB2EN	-	RGB1MEL	RGB1OS	RGB1EN	RGB LED control
26h	W	SFRGB1(1)	SFRGB1(0)	SRRGB1(1)	SRRGB1(0)	-	TRGB1(2)	TRGB1(1)	TRGB1(0)	RGB1-hour setup
27h	W	-	IR11(6)	IR11(5)	IR11(4)	IR11(3)	IR11(2)	IR11(1)	IR11(0)	R1 current 1 setup
28h	W	-	IR12(6)	IR12(5)	IR12(4)	IR12(3)	IR12(2)	IR12(1)	IR12(0)	R1 current 2 setup
29h	W	-	-	-	-	PR1(3)	PR1(2)	PR1(1)	PR1(0)	R1 Wave patturn setup
2Ah	W	-	IG11(6)	IG11(5)	IG11(4)	IG11(3)	IG11(2)	IG11(1)	IG11(0)	G1 current 1 setup
2Bh	W	-	IG12(6)	IG12(5)	IG12(4)	IG12(3)	IG12(2)	IG12(1)	IG12(0)	G1 current 2 setup
2Ch	W	-	-	-	-	PG1(3)	PG1(2)	PG1(1)	PG1(0)	G1 Wave patturn setup
2Dh	W	-	IB11(6)	IB11(5)	IB11(4)	IB11(3)	IB11(2)	IB11(1)	IB11(0)	B1 current 1 setup
2Eh	W	-	IB12(6)	IB12(5)	IB12(4)	IB12(3)	IB12(2)	IB12(1)	IB12(0)	B1 current 2 setup
2Fh	W	-	-	-	-	PB1(3)	PB1(2)	PB1(1)	PB1(0)	B1 Wave patturn setup
30h	W	SFRGB2(1)	SFRGB2(0)	SRRGB2(1)	SRRGB2(0)	-	TRGB2(2)	TRGB2(1)	TRGB2(0)	RGB2-hour setup
31h	W	-	IR21(6)	IR21(5)	IR21(4)	IR21(3)	IR21(2)	IR21(1)	IR21(0)	R2 current 1 setup
32h	W	-	IR22(6)	IR22(5)	IR22(4)	IR22(3)	IR22(2)	IR22(1)	IR22(0)	R2 current 2 setup
33h	W	-	-	-	-	PR2(3)	PR2(2)	PR2(1)	PR2(0)	R2 Wave patturn
34h	W	-	IG21(6)	IG21(5)	IG21(4)	IG21(3)	IG21(2)	IG21(1)	IG21(0)	G2 current 1 setup
35h	W	-	IG22(6)	IG22(5)	IG22(4)	IG22(3)	IG22(2)	IG22(1)	IG22(0)	G2 current 2 setup
36h	W	-	-	-	-	PG2(3)	PG2(2)	PG2(1)	PG2(0)	G2 Wave patturn setup
37h	W	-	IB21(6)	IB21(5)	IB21(4)	IB21(3)	IB21(2)	IB21(1)	IB21(0)	B2 current 1 setup
38h	W	-	IB22(6)	IB22(5)	IB22(4)	IB22(3)	IB22(2)	IB22(1)	IB22(0)	B2 current 2 setup
39h	W	-	-	-	-	PB2(3)	PB2(2)	PB2(1)	PB2(0)	B2 Wave patturn setup

Input "0" for "-".

Vacancy address may be use for test.

Prohibit to accessing the address that isn't mentioned and the register for test.

The time indicated by register explanation is the TYP time made by dividing of the built-in OSC.

●Register Map

Address 00h < Software Reset, DC/DC Function Setup >

Address	R/W	Bit7	Bit6	Bit5	Bit4	Bit3	Bit2	Bit1	Bit0
00h	W	VOUT(1)	VOUT(0)	DCDCMD	DCDCFON	-	-	-	SFTRST
Initial Value	00h	0	0	0	0	-	-	-	0

Bit [7:6] : **VOUT (1:0)** VOUT Output Voltage Setting

“00” : VOUT Output Voltage 3.9V

“01” : VOUT Output Voltage 4.2V

“10” : VOUT Output Voltage 4.5V

“11” : VOUT Output Voltage 4.8V

Refer to “●Description of DC/DC Operations” for detail.

Bit [5:4] : **DCDCMD, DCDCFON** DC/DC Setting

<DC/DC Return Mode>

<DC/DC ON/OFF Control>

“00” : LED Pin Return

Depend on LED ON/OFF

“01” : LEDPin Return

Depend on LED ON/OFF

“10” : Output Voltage Fixation

Depend on LED ON/OFF

“11” : Output Voltage Fixation

Forced ON

Refer to “●Description of DC/DC Operations” for detail.

Bit [3:1] : (Not used)

Bit0 : **SFTRST** Software Reset Command

“0” : Reset cancel

“1” : Reset (All register initializing)

Refer to “1.Reset” of “●Description of other operations” for detail.

Address 01h < LED Pin Function Setup >

Address	R/W	Bit7	Bit6	Bit5	Bit4	Bit3	Bit2	Bit1	Bit0
01h	W	RGB2PW(1)	RGB2PW(0)	RGB1PW(1)	RGB1PW(0)	W7MD	W6MD	W5MD	MLEDMD
Initial Value	00h	0	0	0	0	0	0	0	0

Bit [7:6] : **RGB2PW(1:0)** RGB2 Connection Select (VBAT/VOUT)

	R2LED connection	G2LED connection	B2LED connection
"00" :	VBAT	VBAT	VBAT
"01" :	VBAT	VBAT	VOUT
"10" :	VBAT	VOUT	VOUT
"11" :	VOUT	VOUT	VOUT

Refer to "●RGB LED Driver Operation Description" for detail.

Bit [5:4] : **RGB1PW(1:0)** RGB1 Connection Select (VBAT/VOUT)

	R1LED connection	G1LED connection	B1LED connection
"00" :	VBAT	VBAT	VBAT
"01" :	VBAT	VBAT	VOUT
"10" :	VBAT	VOUT	VOUT
"11" :	VOUT	VOUT	VOUT

Refer to "●RGB LED Driver Operation Description" for detail.

Bit3 : **W7MD** LED7 Control Setting (Individual / Main allocation)

"0" :	LED7 Individual Control
"1" :	LED7 Main group allocation

Refer to "●Description of white LED Driver Operations" for detail.

Bit2 : **W6MD** LED6 Control Setting (Individual / Main allocation)

"0" :	LED6 Individual Control
"1" :	LED6 Main group allocation

Refer to "●Description of white LED Driver Operations" for detail.

Bit1 : **W5MD** LED5 Control Setting (Individual / Main allocation)

"0" :	LED5 Individual Control
"1" :	LED5 Main group allocation

Refer to "●Description of white LED Driver Operations" for detail.

Bit0 : **MLEDMD** "Main Group" LED Mode Select (Non ALC / with ALC)

"0" :	Non ALC mode
"1" :	ALC mode

Refer to "●Description of white LED Driver Operations" for detail.

Refer to "●The explanation of Auto Lighting Control" for detail.

RGB*PW (1:0) does not assume to change dynamically. Please perform a fixed setup per design.
And, do the setup of RGB*PW (1:0) when each LED is Off.

Address 02h < Power Control >

Address	R/W	Bit7	Bit6	Bit5	Bit4	Bit3	Bit2	Bit1	Bit0
02h	W	W7EN	W6EN	W5EN	MLEDEN	REG2CNT	REG2ON	REG1CNT	REG1ON
Initial Value	00h	0	0	0	0	0	0	0	0

Bit7 : **W7EN** LED7 Control (ON/OFF)

“0” : LED7 OFF

“1” : LED7 ON (individual control)

Refer to “●Description of DC/DC Operations” for detail.

Bit6 : **W6EN** LED6 Control (ON/OFF)

“0” : LED6 OFF

“1” : LED6 ON (individual control)

Refer to “●Description of DC/DC Operations” for detail.

Bit5 : **W5EN** LED5 Control (ON/OFF)

“0” : LED5 OFF

“1” : LED5 ON (individual control)

Refer to “●Description of DC/DC Operations” for detail.

Bit4 : **MLEDEN** Main Group LED Control (ON/OFF)

“0” : Main group OFF

“1” : Main group ON

Refer to “●Description of DC/DC Operations” for detail.

Bit3 : **REG2CNT** REG2 Mode Setting (Normal/Low Consumption)

“0” : REG2 Low Consumption Mode

“1” : REG2 Normal Mode

Refer to ●Description of REG Operations” for detail.

Bit2 : **REG2ON** REG2 Control (ON/OFF)

“0” : REG2 OFF

“1” : REG2 ON

Refer to ●Description of REG Operations” for detail.

Bit1 : **REG1CNT** REG1 Mode Setting (Normal/Low Consumption)

“0” : REG1 Low Consumption Mode

“1” : REG1 Normal Mode

Refer to ●Description of REG Operations” for detail.

Bit0 : **REG1ON** REG1 Control (ON/OFF)

“0” : REG1 OFF

“1” : REG1 ON

Refer to ●Description of REG Operations” for detail.

Address 03h < "Main Group" LED Current Setting at non-ALC mode >

Address	R/W	Bit7	Bit6	Bit5	Bit4	Bit3	Bit2	Bit1	Bit0
03h	W	-	IMLED(6)	IMLED(5)	IMLED(4)	IMLED(3)	IMLED(2)	IMLED(1)	IMLED(0)
Initial Value	00h	-	0	0	0	0	0	0	0

Bit7 : (Not used)

Bit [6:0] : **IMLED(6:0)** Main Group LED Current Setting at non-ALC mode

"0000000" : 0.2 mA	"0110010" : 10.2mA	"1100100" : 20.2mA
"0000001" : 0.4 mA	"0110011" : 10.4mA	"1100101" : 20.4mA
"0000010" : 0.6 mA	"0110100" : 10.6mA	"1100110" : 20.6mA
"0000011" : 0.8 mA	"0110101" : 10.8mA	"1100111" : 20.8mA
"0000100" : 1.0 mA	"0110110" : 11.0mA	"1101000" : 21.0mA
"0000101" : 1.2 mA	"0110111" : 11.2mA	"1101001" : 21.2mA
"0000110" : 1.4 mA	"0111000" : 11.4mA	"1101010" : 21.4mA
"0000111" : 1.6 mA	"0111001" : 11.6mA	"1101011" : 21.6mA
"0001000" : 1.8 mA	"0111010" : 11.8mA	"1101100" : 21.8mA
"0001001" : 2.0 mA	"0111011" : 12.0mA	"1101101" : 22.0mA
"0001010" : 2.2 mA	"0111100" : 12.2mA	"1101110" : 22.2mA
"0001011" : 2.4 mA	"0111101" : 12.4mA	"1101111" : 22.4mA
"0001100" : 2.6 mA	"0111110" : 12.6mA	"1110000" : 22.6mA
"0001101" : 2.8 mA	"0111111" : 12.8mA	"1110001" : 22.8mA
"0001110" : 3.0 mA	"1000000" : 13.0mA	"1110010" : 23.0mA
"0001111" : 3.2 mA	"1000001" : 13.2mA	"1110011" : 23.2mA
"0010000" : 3.4 mA	"1000010" : 13.4mA	"1110100" : 23.4mA
"0010001" : 3.6 mA	"1000011" : 13.6mA	"1110101" : 23.6mA
"0010010" : 3.8 mA	"1000100" : 13.8mA	"1110110" : 23.8mA
"0010011" : 4.0 mA	"1000101" : 14.0mA	"1110111" : 24.0mA
"0010100" : 4.2 mA	"1000110" : 13.2mA	"1111000" : 24.2mA
"0010101" : 4.4 mA	"1000111" : 14.4mA	"1111001" : 24.4mA
"0010110" : 4.6 mA	"1001000" : 14.6mA	"1111010" : 24.6mA
"0010111" : 4.8 mA	"1001001" : 14.8mA	"1111011" : 24.8mA
"0011000" : 5.0 mA	"1001010" : 15.0mA	"1111100" : 25.0mA
"0011001" : 5.2 mA	"1001011" : 15.2mA	"1111101" : 25.2mA
"0011010" : 5.4 mA	"1001100" : 15.4mA	"1111110" : 25.4mA
"0011011" : 5.6 mA	"1001101" : 15.6mA	"1111111" : 25.6mA
"0011100" : 5.8 mA	"1001110" : 15.8mA	
"0011101" : 6.0 mA	"1001111" : 16.0mA	
"0011110" : 6.2 mA	"1010000" : 16.2mA	
"0011111" : 6.4 mA	"1010001" : 16.4mA	
"0100000" : 6.6 mA	"1010010" : 16.6mA	
"0100001" : 6.8 mA	"1010011" : 16.8mA	
"0100010" : 7.0 mA	"1010100" : 17.0mA	
"0100011" : 7.2 mA	"1010101" : 17.2mA	
"0100100" : 7.4 mA	"1010110" : 17.4mA	
"0100101" : 7.6 mA	"1010111" : 17.6mA	
"0100110" : 7.8 mA	"1011000" : 17.8mA	
"0100111" : 8.0 mA	"1011001" : 18.0mA	
"0101000" : 8.2 mA	"1011010" : 18.2mA	
"0101001" : 8.4 mA	"1011011" : 18.4mA	
"0101010" : 8.6 mA	"1011100" : 18.6mA	
"0101011" : 8.8 mA	"1011101" : 18.8mA	
"0101100" : 9.0 mA	"1011110" : 19.0mA	
"0101101" : 9.2 mA	"1011111" : 19.2mA	
"0101110" : 9.4 mA	"1100000" : 19.4mA	
"0101111" : 9.6 mA	"1100001" : 19.6mA	
"0110000" : 9.8 mA	"1100010" : 19.8mA	
"0110001" : 10.0 mA	"1100011" : 20.0mA	

Refer to "●Description of white LED Driver Operations" for detail.

Address 04h < LED5 Current setting (Independence control) >

Address	R/W	Bit7	Bit6	Bit5	Bit4	Bit3	Bit2	Bit1	Bit0
04h	W	-	IW5(6)	IW5(5)	IW5(4)	IW5(3)	IW5(2)	IW5(1)	IW5(0)
Initial Value	00h	-	0	0	0	0	0	0	0

Bit7 : (Not used)

Bit [6:0] : **IW5(6:0)** LED5 Current Setting

"0000000" : 0.2 mA	"0110010" : 10.2mA	"1100100" : 20.2mA
"0000001" : 0.4 mA	"0110011" : 10.4mA	"1100101" : 20.4mA
"0000010" : 0.6 mA	"0110100" : 10.6mA	"1100110" : 20.6mA
"0000011" : 0.8 mA	"0110101" : 10.8mA	"1100111" : 20.8mA
"0000100" : 1.0 mA	"0110110" : 11.0mA	"1101000" : 21.0mA
"0000101" : 1.2 mA	"0110111" : 11.2mA	"1101001" : 21.2mA
"0000110" : 1.4 mA	"0111000" : 11.4mA	"1101010" : 21.4mA
"0000111" : 1.6 mA	"0111001" : 11.6mA	"1101011" : 21.6mA
"0001000" : 1.8 mA	"0111010" : 11.8mA	"1101100" : 21.8mA
"0001001" : 2.0 mA	"0111011" : 12.0mA	"1101101" : 22.0mA
"0001010" : 2.2 mA	"0111100" : 12.2mA	"1101110" : 22.2mA
"0001011" : 2.4 mA	"0111101" : 12.4mA	"1101111" : 22.4mA
"0001100" : 2.6 mA	"0111110" : 12.6mA	"1110000" : 22.6mA
"0001101" : 2.8 mA	"0111111" : 12.8mA	"1110001" : 22.8mA
"0001110" : 3.0 mA	"1000000" : 13.0mA	"1110010" : 23.0mA
"0001111" : 3.2 mA	"1000001" : 13.2mA	"1110011" : 23.2mA
"0010000" : 3.4 mA	"1000010" : 13.4mA	"1110100" : 23.4mA
"0010001" : 3.6 mA	"1000011" : 13.6mA	"1110101" : 23.6mA
"0010010" : 3.8 mA	"1000100" : 13.8mA	"1110110" : 23.8mA
"0010011" : 4.0 mA	"1000101" : 14.0mA	"1110111" : 24.0mA
"0010100" : 4.2 mA	"1000110" : 13.2mA	"1111000" : 24.2mA
"0010101" : 4.4 mA	"1000111" : 14.4mA	"1111001" : 24.4mA
"0010110" : 4.6 mA	"1001000" : 14.6mA	"1111010" : 24.6mA
"0010111" : 4.8 mA	"1001001" : 14.8mA	"1111011" : 24.8mA
"0011000" : 5.0 mA	"1001010" : 15.0mA	"1111100" : 25.0mA
"0011001" : 5.2 mA	"1001011" : 15.2mA	"1111101" : 25.2mA
"0011010" : 5.4 mA	"1001100" : 15.4mA	"1111110" : 25.4mA
"0011011" : 5.6 mA	"1001101" : 15.6mA	"1111111" : 25.6mA
"0011100" : 5.8 mA	"1001110" : 15.8mA	
"0011101" : 6.0 mA	"1001111" : 16.0mA	
"0011110" : 6.2 mA	"1010000" : 16.2mA	
"0011111" : 6.4 mA	"1010001" : 16.4mA	
"0100000" : 6.6 mA	"1010010" : 16.6mA	
"0100001" : 6.8 mA	"1010011" : 16.8mA	
"0100010" : 7.0 mA	"1010100" : 17.0mA	
"0100011" : 7.2 mA	"1010101" : 17.2mA	
"0100100" : 7.4 mA	"1010110" : 17.4mA	
"0100101" : 7.6 mA	"1010111" : 17.6mA	
"0100110" : 7.8 mA	"1011000" : 17.8mA	
"0100111" : 8.0 mA	"1011001" : 18.0mA	
"0101000" : 8.2 mA	"1011010" : 18.2mA	
"0101001" : 8.4 mA	"1011011" : 18.4mA	
"0101010" : 8.6 mA	"1011100" : 18.6mA	
"0101011" : 8.8 mA	"1011101" : 18.8mA	
"0101100" : 9.0 mA	"1011110" : 19.0mA	
"0101101" : 9.2 mA	"1011111" : 19.2mA	
"0101110" : 9.4 mA	"1100000" : 19.4mA	
"0101111" : 9.6 mA	"1100001" : 19.6mA	
"0110000" : 9.8 mA	"1100010" : 19.8mA	
"0110001" : 10.0 mA	"1100011" : 20.0mA	

Refer to "●Description of white LED Driver Operations" for detail.

Address 05h < LED6 Current setting (Independence control) >

Address	R/W	Bit7	Bit6	Bit5	Bit4	Bit3	Bit2	Bit1	Bit0
05h	W	-	IW6(6)	IW6(5)	IW6(4)	IW6(3)	IW6(2)	IW6(1)	IW6(0)
Initial Value	00h	-	0	0	0	0	0	0	0

Bit7 : (Not used)

Bit [6:0] : **IW6(6:0)** LED6 Current Setting

"0000000" : 0.2 mA	"0110010" : 10.2mA	"1100100" : 20.2mA
"0000001" : 0.4 mA	"0110011" : 10.4mA	"1100101" : 20.4mA
"0000010" : 0.6 mA	"0110100" : 10.6mA	"1100110" : 20.6mA
"0000011" : 0.8 mA	"0110101" : 10.8mA	"1100111" : 20.8mA
"0000100" : 1.0 mA	"0110110" : 11.0mA	"1101000" : 21.0mA
"0000101" : 1.2 mA	"0110111" : 11.2mA	"1101001" : 21.2mA
"0000110" : 1.4 mA	"0111000" : 11.4mA	"1101010" : 21.4mA
"0000111" : 1.6 mA	"0111001" : 11.6mA	"1101011" : 21.6mA
"0001000" : 1.8 mA	"0111010" : 11.8mA	"1101100" : 21.8mA
"0001001" : 2.0 mA	"0111011" : 12.0mA	"1101101" : 22.0mA
"0001010" : 2.2 mA	"0111100" : 12.2mA	"1101110" : 22.2mA
"0001011" : 2.4 mA	"0111101" : 12.4mA	"1101111" : 22.4mA
"0001100" : 2.6 mA	"0111110" : 12.6mA	"1110000" : 22.6mA
"0001101" : 2.8 mA	"0111111" : 12.8mA	"1110001" : 22.8mA
"0001110" : 3.0 mA	"1000000" : 13.0mA	"1110010" : 23.0mA
"0001111" : 3.2 mA	"1000001" : 13.2mA	"1110011" : 23.2mA
"0010000" : 3.4 mA	"1000010" : 13.4mA	"1110100" : 23.4mA
"0010001" : 3.6 mA	"1000011" : 13.6mA	"1110101" : 23.6mA
"0010010" : 3.8 mA	"1000100" : 13.8mA	"1110110" : 23.8mA
"0010011" : 4.0 mA	"1000101" : 14.0mA	"1110111" : 24.0mA
"0010100" : 4.2 mA	"1000110" : 13.2mA	"1111000" : 24.2mA
"0010101" : 4.4 mA	"1000111" : 14.4mA	"1111001" : 24.4mA
"0010110" : 4.6 mA	"1001000" : 14.6mA	"1111010" : 24.6mA
"0010111" : 4.8 mA	"1001001" : 14.8mA	"1111011" : 24.8mA
"0011000" : 5.0 mA	"1001010" : 15.0mA	"1111100" : 25.0mA
"0011001" : 5.2 mA	"1001011" : 15.2mA	"1111101" : 25.2mA
"0011010" : 5.4 mA	"1001100" : 15.4mA	"1111110" : 25.4mA
"0011011" : 5.6 mA	"1001101" : 15.6mA	"1111111" : 25.6mA
"0011100" : 5.8 mA	"1001110" : 15.8mA	
"0011101" : 6.0 mA	"1001111" : 16.0mA	
"0011110" : 6.2 mA	"1010000" : 16.2mA	
"0011111" : 6.4 mA	"1010001" : 16.4mA	
"0100000" : 6.6 mA	"1010010" : 16.6mA	
"0100001" : 6.8 mA	"1010011" : 16.8mA	
"0100010" : 7.0 mA	"1010100" : 17.0mA	
"0100011" : 7.2 mA	"1010101" : 17.2mA	
"0100100" : 7.4 mA	"1010110" : 17.4mA	
"0100101" : 7.6 mA	"1010111" : 17.6mA	
"0100110" : 7.8 mA	"1011000" : 17.8mA	
"0100111" : 8.0 mA	"1011001" : 18.0mA	
"0101000" : 8.2 mA	"1011010" : 18.2mA	
"0101001" : 8.4 mA	"1011011" : 18.4mA	
"0101010" : 8.6 mA	"1011100" : 18.6mA	
"0101011" : 8.8 mA	"1011101" : 18.8mA	
"0101100" : 9.0 mA	"1011110" : 19.0mA	
"0101101" : 9.2 mA	"1011111" : 19.2mA	
"0101110" : 9.4 mA	"1100000" : 19.4mA	
"0101111" : 9.6 mA	"1100001" : 19.6mA	
"0110000" : 9.8 mA	"1100010" : 19.8mA	
"0110001" : 10.0 mA	"1100011" : 20.0mA	

Refer to "●Description of white LED Driver Operations" for detail.

Address 06h < LED7 Current setting (Independence control) >

Address	R/W	Bit7	Bit6	Bit5	Bit4	Bit3	Bit2	Bit1	Bit0
06h	W	-	IW7(6)	IW7(5)	IW7(4)	IW7(3)	IW7(2)	IW7(1)	IW7(0)
Initial Value	00h	-	0	0	0	0	0	0	0

Bit7 : (Not used)

Bit [6:0] : **IW7(6:0)** LED7 Current Setting

"0000000" : 0.2 mA	"0110010" : 10.2mA	"1100100" : 20.2mA
"0000001" : 0.4 mA	"0110011" : 10.4mA	"1100101" : 20.4mA
"0000010" : 0.6 mA	"0110100" : 10.6mA	"1100110" : 20.6mA
"0000011" : 0.8 mA	"0110101" : 10.8mA	"1100111" : 20.8mA
"0000100" : 1.0 mA	"0110110" : 11.0mA	"1101000" : 21.0mA
"0000101" : 1.2 mA	"0110111" : 11.2mA	"1101001" : 21.2mA
"0000110" : 1.4 mA	"0111000" : 11.4mA	"1101010" : 21.4mA
"0000111" : 1.6 mA	"0111001" : 11.6mA	"1101011" : 21.6mA
"0001000" : 1.8 mA	"0111010" : 11.8mA	"1101100" : 21.8mA
"0001001" : 2.0 mA	"0111011" : 12.0mA	"1101101" : 22.0mA
"0001010" : 2.2 mA	"0111100" : 12.2mA	"1101110" : 22.2mA
"0001011" : 2.4 mA	"0111101" : 12.4mA	"1101111" : 22.4mA
"0001100" : 2.6 mA	"0111110" : 12.6mA	"1110000" : 22.6mA
"0001101" : 2.8 mA	"0111111" : 12.8mA	"1110001" : 22.8mA
"0001110" : 3.0 mA	"1000000" : 13.0mA	"1110010" : 23.0mA
"0001111" : 3.2 mA	"1000001" : 13.2mA	"1110011" : 23.2mA
"0010000" : 3.4 mA	"1000010" : 13.4mA	"1110100" : 23.4mA
"0010001" : 3.6 mA	"1000011" : 13.6mA	"1110101" : 23.6mA
"0010010" : 3.8 mA	"1000100" : 13.8mA	"1110110" : 23.8mA
"0010011" : 4.0 mA	"1000101" : 14.0mA	"1110111" : 24.0mA
"0010100" : 4.2 mA	"1000110" : 13.2mA	"1111000" : 24.2mA
"0010101" : 4.4 mA	"1000111" : 14.4mA	"1111001" : 24.4mA
"0010110" : 4.6 mA	"1001000" : 14.6mA	"1111010" : 24.6mA
"0010111" : 4.8 mA	"1001001" : 14.8mA	"1111011" : 24.8mA
"0011000" : 5.0 mA	"1001010" : 15.0mA	"1111100" : 25.0mA
"0011001" : 5.2 mA	"1001011" : 15.2mA	"1111101" : 25.2mA
"0011010" : 5.4 mA	"1001100" : 15.4mA	"1111110" : 25.4mA
"0011011" : 5.6 mA	"1001101" : 15.6mA	"1111111" : 25.6mA
"0011100" : 5.8 mA	"1001110" : 15.8mA	
"0011101" : 6.0 mA	"1001111" : 16.0mA	
"0011110" : 6.2 mA	"1010000" : 16.2mA	
"0011111" : 6.4 mA	"1010001" : 16.4mA	
"0100000" : 6.6 mA	"1010010" : 16.6mA	
"0100001" : 6.8 mA	"1010011" : 16.8mA	
"0100010" : 7.0 mA	"1010100" : 17.0mA	
"0100011" : 7.2 mA	"1010101" : 17.2mA	
"0100100" : 7.4 mA	"1010110" : 17.4mA	
"0100101" : 7.6 mA	"1010111" : 17.6mA	
"0100110" : 7.8 mA	"1011000" : 17.8mA	
"0100111" : 8.0 mA	"1011001" : 18.0mA	
"0101000" : 8.2 mA	"1011010" : 18.2mA	
"0101001" : 8.4 mA	"1011011" : 18.4mA	
"0101010" : 8.6 mA	"1011100" : 18.6mA	
"0101011" : 8.8 mA	"1011101" : 18.8mA	
"0101100" : 9.0 mA	"1011110" : 19.0mA	
"0101101" : 9.2 mA	"1011111" : 19.2mA	
"0101110" : 9.4 mA	"1100000" : 19.4mA	
"0101111" : 9.6 mA	"1100001" : 19.6mA	
"0110000" : 9.8 mA	"1100010" : 19.8mA	
"0110001" : 10.0 mA	"1100011" : 20.0mA	

Refer to "●Description of white LED Driver Operations" for detail.

Address 07h < Main Current transition >

Address	R/W	Bit7	Bit6	Bit5	Bit4	Bit3	Bit2	Bit1	Bit0
07h	W	THL(3)	THL(2)	THL(1)	THL(0)	TLH(3)	TLH(2)	TLH(1)	TLH(0)
Initial Value	C7h	1	1	0	0	0	1	1	1

Bit [7:4] : **THL(3:0)** Main LED current Down transition per 0.2mA step

"0000" :	0.256 ms
"0001" :	0.512 ms
"0010" :	1.024 ms
"0011" :	2.048 ms
"0100" :	4.096 ms
"0101" :	8.192 ms
"0110" :	16.38 ms
"0111" :	32.77 ms
"1000" :	65.54 ms
"1001" :	131.1 ms
"1010" :	196.6 ms
"1011" :	262.1 ms
"1100" :	327.7 ms (Initial value)
"1101" :	393.2 ms
"1110" :	458.8 ms
"1111" :	524.3 ms

Setting time is counted based on the switching frequency of Charge Pump.

The above value becomes the value of the Typ (1MHz) time.

Refer to "9. Slope process" of "●The explanation of Auto Lighting Control" for detail.

Bit [3:0] : **TLH(3:0)** Main LED current Up transition per 0.2mA step

"0000" :	0.256 ms
"0001" :	0.512 ms
"0010" :	1.024 ms
"0011" :	2.048 ms
"0100" :	4.096 ms
"0101" :	8.192 ms
"0110" :	16.38 ms
"0111" :	32.77 ms (Initial value)
"1000" :	65.54 ms
"1001" :	131.1 ms
"1010" :	196.6 ms
"1011" :	262.1 ms
"1100" :	327.7 ms
"1101" :	393.2 ms
"1110" :	458.8 ms
"1111" :	524.3 ms

Setting time is counted based on the switching frequency of Charge Pump.

The above value becomes the value of the Typ (1MHz) time.

Refer to "9. Slope process" of "●The explanation of Auto Lighting Control" for detail.

Address 08h < Main Current Offset >

Address	R/W	Bit7	Bit6	Bit5	Bit4	Bit3	Bit2	Bit1	Bit0
08h	W	-	-	IOFS(5)	IOFS(4)	IOFS(3)	IOFS(2)	IOFS(1)	IOFS(0)
Initial Value	00h	-	-	0	0	0	0	0	0

Bit [7:6] : (Not used)

Bit [5:0] : **IOFS(5:0)** Main Current Offset

"000000" :	0.0 mA	"100000" :	-6.4 mA
"000001" :	-0.2 mA	"100001" :	-6.6 mA
"000010" :	-0.3 mA	"100010" :	-6.8 mA
"000011" :	-0.4 mA	"100011" :	-7.0 mA
"000100" :	-0.8 mA	"100100" :	-7.2 mA
"000101" :	-1.0 mA	"100101" :	-7.4 mA
"000110" :	-1.2 mA	"100110" :	-7.6 mA
"000111" :	-1.4 mA	"100111" :	-7.8 mA
"001000" :	-1.6 mA	"101000" :	-8.0 mA
"001001" :	-1.8 mA	"101001" :	-8.2 mA
"001010" :	-2.0 mA	"101010" :	-8.4 mA
"001011" :	-2.2 mA	"101011" :	-8.6 mA
"001100" :	-2.4 mA	"101100" :	-8.8 mA
"001101" :	-2.6 mA	"101101" :	-9.0 mA
"001110" :	-2.8 mA	"101110" :	-9.2 mA
"001111" :	-3.0 mA	"101111" :	-9.4 mA
"010000" :	-3.2 mA	"110000" :	-9.6 mA
"010001" :	-3.4 mA	"110001" :	-9.8 mA
"010010" :	-3.6 mA	"110010" :	-10.0 mA
"010011" :	-3.8 mA	"110011" :	-10.2 mA
"010100" :	-4.0 mA	"110100" :	-10.4 mA
"010101" :	-4.2 mA	"110101" :	-10.6 mA
"010110" :	-4.4 mA	"110110" :	-10.8 mA
"010111" :	-4.6 mA	"110111" :	-11.0 mA
"011000" :	-4.8 mA	"111000" :	-11.2 mA
"011001" :	-5.0 mA	"111001" :	-11.4 mA
"011010" :	-5.2 mA	"111010" :	-11.6 mA
"011011" :	-5.4 mA	"111011" :	-11.8 mA
"011100" :	-5.6 mA	"111100" :	-12.0 mA
"011101" :	-5.8 mA	"111101" :	-12.2 mA
"011110" :	-6.0 mA	"111110" :	-12.4 mA
"011111" :	-6.2 mA	"111111" :	-12.6 mA

fer to "10. Back light current value External adjustmen 1" of "●The explanation of Auto Lighting Control" for detail.

Address 09h < OSYNC Main Current transition >

Address	R/W	Bit7	Bit6	Bit5	Bit4	Bit3	Bit2	Bit1	Bit0
09h	W	WPWMEN	SBIASON	-	OSYNCEN	-	OSSLP(2)	OSSLP(1)	OSSLP(0)
Initial Value	40h	0	1	-	0	-	0	0	0

Bit7 : **WPWMEN** External PWM Input "WPWMIN" terminal Enable Control (Valid/Invalid)

"0" : WPWMIN input invalid

"1" : WPWMIN input valid

Refer to "11. Back light current value External adjustmen 2" of "●The explanation of Auto Lighting Control" for detail.

Bit6 : **SBIASON** SBIAS Control (ON/OFF)

"0" : Measurement cycle synchronous

"1" : Usually ON (at ALCEN=1) (Initial value)

Refer to "4. AD conversion" of "●The explanation of Auto Lighting Control" for detail.

Bit5 : (Not used)

Bit4 : **OSYNCEN**

"0" :

"1" :

Refer to "10. Back light current value External adjustmen 1" of "●The explanation of Auto Lighting Control" for detail.

Bit3 : (Not used)

Bit [2:0] : **OSSLP(2:0)** Current Offset Slope Control transition per 0.2mA step

"000" : 0.000 ms (Initial value)

"001" : 0.064 ms

"010" : 0.128 ms

"011" : 0.256 ms

"100" : 0.512 ms

"101" : 1.024 ms

"110" : 2.048 ms

"111" : 4.096 ms

Setting time is counted based on the switching frequency of Charge Pump.

The above value becomes the value of the Typ (1MHz) time.

Refer to "10. Back light current value External adjustmen 1" of "●The explanation of Auto Lighting Control" for detail.

Address 0Ah < Main Current Data Output >

Address	R/W	Bit7	Bit6	Bit5	Bit4	Bit3	Bit2	Bit1	Bit0
0Ah	R	-	IALED(6)	IALED(5)	IALED(4)	IALED(3)	IALED(2)	IALED(1)	IALED(0)
Initial Value	-	-	-	-	-	-	-	-	-

Bit7 : (Not used)

Bit [6:0] : IALED(6:0) Main Current Data Output

"0000000" : 0.2 mA	"0110010" : 10.2mA	"1100100" : 20.2mA
"0000001" : 0.4 mA	"0110011" : 10.4mA	"1100101" : 20.4mA
"0000010" : 0.6 mA	"0110100" : 10.6mA	"1100110" : 20.6mA
"0000011" : 0.8 mA	"0110101" : 10.8mA	"1100111" : 20.8mA
"0000100" : 1.0 mA	"0110110" : 11.0mA	"1101000" : 21.0mA
"0000101" : 1.2 mA	"0110111" : 11.2mA	"1101001" : 21.2mA
"0000110" : 1.4 mA	"0111000" : 11.4mA	"1101010" : 21.4mA
"0000111" : 1.6 mA	"0111001" : 11.6mA	"1101011" : 21.6mA
"0001000" : 1.8 mA	"0111010" : 11.8mA	"1101100" : 21.8mA
"0001001" : 2.0 mA	"0111011" : 12.0mA	"1101101" : 22.0mA
"0001010" : 2.2 mA	"0111100" : 12.2mA	"1101110" : 22.2mA
"0001011" : 2.4 mA	"0111101" : 12.4mA	"1101111" : 22.4mA
"0001100" : 2.6 mA	"0111110" : 12.6mA	"1110000" : 22.6mA
"0001101" : 2.8 mA	"0111111" : 12.8mA	"1110001" : 22.8mA
"0001110" : 3.0 mA	"1000000" : 13.0mA	"1110010" : 23.0mA
"0001111" : 3.2 mA	"1000001" : 13.2mA	"1110011" : 23.2mA
"0010000" : 3.4 mA	"1000010" : 13.4mA	"1110100" : 23.4mA
"0010001" : 3.6 mA	"1000011" : 13.6mA	"1110101" : 23.6mA
"0010010" : 3.8 mA	"1000100" : 13.8mA	"1110110" : 23.8mA
"0010011" : 4.0 mA	"1000101" : 14.0mA	"1110111" : 24.0mA
"0010100" : 4.2 mA	"1000110" : 13.2mA	"1111000" : 24.2mA
"0010101" : 4.4 mA	"1000111" : 14.4mA	"1111001" : 24.4mA
"0010110" : 4.6 mA	"1001000" : 14.6mA	"1111010" : 24.6mA
"0010111" : 4.8 mA	"1001001" : 14.8mA	"1111011" : 24.8mA
"0011000" : 5.0 mA	"1001010" : 15.0mA	"1111100" : 25.0mA
"0011001" : 5.2 mA	"1001011" : 15.2mA	"1111101" : 25.2mA
"0011010" : 5.4 mA	"1001100" : 15.4mA	"1111110" : 25.4mA
"0011011" : 5.6 mA	"1001101" : 15.6mA	"1111111" : 25.6mA
"0011100" : 5.8 mA	"1001110" : 15.8mA	
"0011101" : 6.0 mA	"1001111" : 16.0mA	
"0011110" : 6.2 mA	"1010000" : 16.2mA	
"0011111" : 6.4 mA	"1010001" : 16.4mA	
"0100000" : 6.6 mA	"1010010" : 16.6mA	
"0100001" : 6.8 mA	"1010011" : 16.8mA	
"0100010" : 7.0 mA	"1010100" : 17.0mA	
"0100011" : 7.2 mA	"1010101" : 17.2mA	
"0100100" : 7.4 mA	"1010110" : 17.4mA	
"0100101" : 7.6 mA	"1010111" : 17.6mA	
"0100110" : 7.8 mA	"1011000" : 17.8mA	
"0100111" : 8.0 mA	"1011001" : 18.0mA	
"0101000" : 8.2 mA	"1011010" : 18.2mA	
"0101001" : 8.4 mA	"1011011" : 18.4mA	
"0101010" : 8.6 mA	"1011100" : 18.6mA	
"0101011" : 8.8 mA	"1011101" : 18.8mA	
"0101100" : 9.0 mA	"1011110" : 19.0mA	
"0101101" : 9.2 mA	"1011111" : 19.2mA	
"0101110" : 9.4 mA	"1100000" : 19.4mA	
"0101111" : 9.6 mA	"1100001" : 19.6mA	
"0110000" : 9.8 mA	"1100010" : 19.8mA	
"0110001" : 10.0 mA	"1100011" : 20.0mA	

The data can be read through I²C.

Refer to "9. Slope process" of "●The explanation of Auto Lighting Control" for detail.

Address 0Bh < Measurement Mode Setting >

Address	R/W	Bit7	Bit6	Bit5	Bit4	Bit3	Bit2	Bit1	Bit0
0Bh	W	ADCYC(1)	ADCYC(0)	GAIN(1)	GAIN(0)	STYPE	VSB	MDCIR	ALCEN
Initial Value	80h	1	0	0	0	0	0	0	0

Bit [7:6] : **ADCYC(1:0)** ADC Measurement Cycle

- "00" : 0.52 s
- "01" : 1.05 s
- "10" : 1.57 s (Initial value)
- "11" : 2.10 s

Setup time is counted based on the switching frequency of DC/DC. The above value becomes the value of the Typ (1MHz) time.

Refer to "●Automatic brightness control operation explanation" for the detailed function of each register of this page.

Refer to "4. AD conversion" of "●The explanation of Auto Lighting Control" for detail.

Bit [5:4] : **GAIN(1:0)** Sensor Gain Switching Function Control (This is effective only at STYPE="0".)

- "00" : Auto Change (Initial value)
- "01" : High
- "10" : Low
- "11" : Fixed

Refer to "3. I/V conversion" of "●The explanation of Auto Lighting Control" for detail.

Bit3 : **STYPE** Ambient Light Sensor Type Select (Linear/Logarithm)

- "0" : For Linear sensor (Initial value)
- "1" : For Log sensor

Refer to "3. I/V conversion" of "●The explanation of Auto Lighting Control" for detail.

Bit2 : **VSB** SBIAS Output Voltage Control

- "0" : SBIAS output voltage 3.0V (Initial value)
- "1" : SBIAS output voltage 2.6V

Refer to "2. Sensor I/F" of "●The explanation of Auto Lighting Control" for detail.

Bit1 : **MDCIR** LED Current Reset Select by Mode Change

- "0" : LED current non-reset when mode change (Initial value)
- "1" : LED current reset when mode change

Refer to "9. Slope process" of "●The explanation of Auto Lighting Control" for detail.

Bit0 : **ALCEN** ALC Function Control (ON/OFF)

- "0" : ALC function OFF
- "1" : ALC function ON

Refer to "1. Auto Lighting Control ON/OFF" of "●The explanation of Auto Lighting Control" for detail.

Address 0Ch < ADC Data adjustment >

Address	R/W	Bit7	Bit6	Bit5	Bit4	Bit3	Bit2	Bit1	Bit0
0Ch	W	SOFS(3)	SOFS(2)	SOFS(1)	SOFS(0)	SGAIN(3)	SGAIN(2)	SGAIN(1)	SGAIN(0)
Initial Value	00h	0	0	0	0	0	0	0	0

Bit [7:4] : **SOFS(3:0)** AD Data Offset Adjustment

"1000" :	-8 LSB
"1001" :	-7 LSB
"1010" :	-6 LSB
"1011" :	-5 LSB
"1100" :	-4 LSB
"1101" :	-3 LSB
"1110" :	-2 LSB
"1111" :	-1 LSB
"0000" :	non-adjust
"0001" :	+1 LSB
"0010" :	+2 LSB
"0011" :	+3 LSB
"0100" :	+4 LSB
"0101" :	+5 LSB
"0110" :	+6 LSB
"0111" :	+7 LSB

Offset adjust is performed to ADC data.

Refer to "5. ADC data gain offset adjust" of "●The explanation of Auto Lighting Control" for detail.

Bit [3:0] : **SGAIN(3:0)** AD Data Gain Adjustment

"1000" :	reserved
"1001" :	reserved
"1010" :	-37.50%
"1011" :	-31.25%
"1100" :	-25.00%
"1101" :	-18.75%
"1110" :	-12.50%
"1111" :	-6.25%
"0000" :	non-adjust
"0001" :	+6.25%
"0010" :	+12.50%
"0011" :	+18.75%
"0100" :	+25.00%
"0101" :	+31.25%
"0110" :	+37.50%
"0111" :	reserved

Gain adjust is performed to ADC data.

The data after adjustment are round off by 8-bit data.

Refer to "5. ADC data gain offset adjust" of "●The explanation of Auto Lighting Control" for detail.

Address 0Dh < Ambient level (Read Only) >

Address	R/W	Bit7	Bit6	Bit5	Bit4	Bit3	Bit2	Bit1	Bit0
0Dh	R	-	-	-	-	AMB(3)	AMB(2)	AMB(1)	AMB(0)
Initial Value	-	-	-	-	-	-	-	-	-

Bit [7:4] : (Not used)

Bit [3:0] : **AMB(3:0)** Ambient Level

"0000" : 0h
 "0001" : 1h
 "0010" : 2h
 "0011" : 3h
 "0100" : 4h
 "0101" : 5h
 "0110" : 6h
 "0111" : 7h
 "1000" : 8h
 "1001" : 9h
 "1010" : Ah
 "1011" : Bh
 "1100" : Ch
 "1101" : Dh
 "1110" : Eh
 "1111" : Fh

The data can be read through I²C.

Refer to "7. Brightness data conversion" of "●The explanation of Auto Lighting Control" for detail.

Address 0Eh~1Dh < Main Current at Ambient level 0h~Fh >

Address	R/W	Bit7	Bit6	Bit5	Bit4	Bit3	Bit2	Bit1	Bit0
0Eh~1Dh	W	-	IU*(6)	IU*(5)	IU*(4)	IU*(3)	IU*(2)	IU*(1)	IU*(0)
Initial Value	-	Refer to after page for initial table.							

“*” means 0~F.

Bit7 : (Not used)

Bit [6:0] : **IU*(6:0)** Main Current at Ambient Level for 0h~Fh

“0000000” : 0.2 mA	“0110010” : 10.2mA	“1100100” : 20.2mA
“0000001” : 0.4 mA	“0110011” : 10.4mA	“1100101” : 20.4mA
“0000010” : 0.6 mA	“0110100” : 10.6mA	“1100110” : 20.6mA
“0000011” : 0.8 mA	“0110101” : 10.8mA	“1100111” : 20.8mA
“0000100” : 1.0 mA	“0110110” : 11.0mA	“1101000” : 21.0mA
“0000101” : 1.2 mA	“0110111” : 11.2mA	“1101001” : 21.2mA
“0000110” : 1.4 mA	“0111000” : 11.4mA	“1101010” : 21.4mA
“0000111” : 1.6 mA	“0111001” : 11.6mA	“1101011” : 21.6mA
“0001000” : 1.8 mA	“0111010” : 11.8mA	“1101100” : 21.8mA
“0001001” : 2.0 mA	“0111011” : 12.0mA	“1101101” : 22.0mA
“0001010” : 2.2 mA	“0111100” : 12.2mA	“1101110” : 22.2mA
“0001011” : 2.4 mA	“0111101” : 12.4mA	“1101111” : 22.4mA
“0001100” : 2.6 mA	“0111110” : 12.6mA	“1110000” : 22.6mA
“0001101” : 2.8 mA	“0111111” : 12.8mA	“1110001” : 22.8mA
“0001110” : 3.0 mA	“1000000” : 13.0mA	“1110010” : 23.0mA
“0001111” : 3.2 mA	“1000001” : 13.2mA	“1110011” : 23.2mA
“0010000” : 3.4 mA	“1000010” : 13.4mA	“1110100” : 23.4mA
“0010001” : 3.6 mA	“1000011” : 13.6mA	“1110101” : 23.6mA
“0010010” : 3.8 mA	“1000100” : 13.8mA	“1110110” : 23.8mA
“0010011” : 4.0 mA	“1000101” : 14.0mA	“1110111” : 24.0mA
“0010100” : 4.2 mA	“1000110” : 13.2mA	“1111000” : 24.2mA
“0010101” : 4.4 mA	“1000111” : 14.4mA	“1111001” : 24.4mA
“0010110” : 4.6 mA	“1001000” : 14.6mA	“1111010” : 24.6mA
“0010111” : 4.8 mA	“1001001” : 14.8mA	“1111011” : 24.8mA
“0011000” : 5.0 mA	“1001010” : 15.0mA	“1111100” : 25.0mA
“0011001” : 5.2 mA	“1001011” : 15.2mA	“1111101” : 25.2mA
“0011010” : 5.4 mA	“1001100” : 15.4mA	“1111110” : 25.4mA
“0011011” : 5.6 mA	“1001101” : 15.6mA	“1111111” : 25.6mA
“0011100” : 5.8 mA	“1001110” : 15.8mA	
“0011101” : 6.0 mA	“1001111” : 16.0mA	
“0011110” : 6.2 mA	“1010000” : 16.2mA	
“0011111” : 6.4 mA	“1010001” : 16.4mA	
“0100000” : 6.6 mA	“1010010” : 16.6mA	
“0100001” : 6.8 mA	“1010011” : 16.8mA	
“0100010” : 7.0 mA	“1010100” : 17.0mA	
“0100011” : 7.2 mA	“1010101” : 17.2mA	
“0100100” : 7.4 mA	“1010110” : 17.4mA	
“0100101” : 7.6 mA	“1010111” : 17.6mA	
“0100110” : 7.8 mA	“1011000” : 17.8mA	
“0100111” : 8.0 mA	“1011001” : 18.0mA	
“0101000” : 8.2 mA	“1011010” : 18.2mA	
“0101001” : 8.4 mA	“1011011” : 18.4mA	
“0101010” : 8.6 mA	“1011100” : 18.6mA	
“0101011” : 8.8 mA	“1011101” : 18.8mA	
“0101100” : 9.0 mA	“1011110” : 19.0mA	
“0101101” : 9.2 mA	“1011111” : 19.2mA	
“0101110” : 9.4 mA	“1100000” : 19.4mA	
“0101111” : 9.6 mA	“1100001” : 19.6mA	
“0110000” : 9.8 mA	“1100010” : 19.8mA	
“0110001” : 10.0 mA	“1100011” : 20.0mA	

Refer to “8. LED current conversion” of “●The explanation of Auto Lighting Control” for detail.

Address 1Eh < Key Driver Control >

Address	R/W	Bit7	Bit6	Bit5	Bit4	Bit3	Bit2	Bit1	Bit0
1Eh	W	-	-	KBSLP(1)	KBSLP(0)	MDTY(3)	MDTY(2)	MDTY(1)	MDTY(0)
Initial Value	00h	-	-	0	0	0	0	0	0

Bit [7:6] : (Not used)

Bit [5:4] : **KBSLP(1:0)** PWM Slope time

"00" : 0.00ms

"01" : 32.77ms

"10" : 65.54ms

"11" : 131.00ms

"PWM Slope time" is the time for transiting one step of each value prepared as MAX DUTY.

Refer to "13. Key Backlight PWM Control" of "●The explanation of Auto Lighting Control" for detail.

Bit [3:0] : **MDTY(3:0)** MAX DUTY

"0000" : 0% (OFF)

"0001" : 1.7%

"0010" : 3.1%

"0011" : 4.7%

"0100" : 6.3%

"0101" : 9.4%

"0110" : 12.5%

"0111" : 15.6%

"1000" : 18.8%

"1001" : 25.0%

"1010" : 31.3%

"1011" : 39.1%

"1100" : 48.4%

"1101" : 62.5%

"1110" : 78.1%

"1111" : 100%

MAX DUTY shows H level section

Refer to "13. Key Backlight PWM Control" of "●The explanation of Auto Lighting Control" for detail.

Address 1Fh < Key Driver ON/OFF control >

Address	R/W	Bit7	Bit6	Bit5	Bit4	Bit3	Bit2	Bit1	Bit0
1Fh	W	-	-	CHYS(1)	CHYS(0)	CTH(3)	CTH(2)	CTH(1)	CTH(0)
Initial Value	2Ah	-	-	1	0	1	0	1	0

Bit [7:6] : (Not used)

Bit [5:4] : **CHYS(1:0)** Key Driver Hysteresis Setting

<Hysteresis (to ON)>

- "00" : Detect threshold level -1h
- "01" : Detect threshold level -2h
- "10" : Detect threshold level -3h
- "11" : Detect threshold level -4h

Detect threshold level-1h is the hysteresis width to the brightness set up by CTH (3:0)

Refer to "12. Key Backlight Binary Judgment" of "●The explanation of Auto Lighting Control" for detail.

Bit [3:0] : **CTH(3:0)** Key Driver Detect Threshold Level Setting

<Detect threshold level (to OFF)>

- "0000" : Brightness 0h : OFF
- "0001" : Brightness 1h : OFF
- "0010" : Brightness 2h : OFF
- "0011" : Brightness 3h : OFF
- "0100" : Brightness 4h : OFF
- "0101" : Brightness 5h : OFF
- "0110" : Brightness 6h : OFF
- "0111" : Brightness 7h : OFF
- "1000" : Brightness 8h : OFF
- "1001" : Brightness 9h : OFF
- "1010" : Brightness Ah : OFF
- "1011" : Brightness Bh : OFF
- "1100" : Brightness Ch : OFF
- "1101" : Brightness Dh : OFF
- "1110" : Brightness Eh : OFF
- "1111" : Brightness Fh : OFF

Refer to "12. Key Backlight Binary Judgment" of "●The explanation of Auto Lighting Control" or detail.

Address 20h < GPIO Input/Output setup >

Address	R/W	Bit7	Bit6	Bit5	Bit4	Bit3	Bit2	Bit1	Bit0
20h	W	B2GPO	G2GPO	R2GPO	KBFIX	GP4DIR	GP3DIR	GP2DIR	GP1DIR
Initial Value	00h	0	0	0	0	0	0	0	0

Bit7 : **B2GPO** B2LED Mode Setting (LED Driver / GPO)

“0” : B2LED LED Driver mode (Initial value)

“1” : B2LED GPO mode

B2GPO does not assume to change dynamically. Please perform a fixed setup per design.

Refer to “●General-purpose I/O Ports (GPIO1-GPIO4)” for detail.

Bit6 : **G2GPO** G2LED Mode Setting (LED Driver / GPO)

“0” : G2LED LED Driver mode (Initial value)

“1” : G2LED GPO mode

G2GPO does not assume to change dynamically. Please perform a fixed setup per design.

Refer to “●General-purpose I/O Ports (GPIO1-GPIO4)” for detail.

Bit5 : **R2GPO** R2LED Mode Setting (LED Driver / GPO)

“0” : R2LED LED Driver mode (Initial value)

“1” : R2LED GPO mode

R2GPO does not assume to change dynamically. Please perform a fixed setup per design.

Refer to “●General-purpose I/O Ports (GPIO1-GPIO4)” for detail.

Bit4 : **KBFIX** KBLT Mode Setting (ALC / Fix)

“0” : KBLT ALC mode (Initial value)

“1” : KBLT Fix mode

Refer to “●Key Backlight Controller” for detail.

Bit3 : **GP4DIR** GPIO4 Mode Setting (Input / Output)

“0” : GPIO4 Input mode (Initial value)

“1” : GPIO4 Output mode

Refer to “●General-purpose I/O Ports (GPIO1-GPIO4)” for detail.

Bit2 : **GP3DIR** GPIO3 Mode Setting (Input / Output)

“0” : GPIO3 Input mode (Initial value)

“1” : GPIO3 Output mode

Refer to “●General-purpose I/O Ports (GPIO1-GPIO4)” for detail.

Bit1 : **GP2DIR** GPIO2 Mode Setting (Input / Output)

“0” : GPIO2 Input mode (Initial value)

“1” : GPIO2 Output mode

Refer to “●General-purpose I/O Ports (GPIO1-GPIO4)” for detail.

Bit0 : **GP1DIR** GPIO1 Mode Setting (Input / Output)

“0” : GPIO1 Input mode (Initial value)

“1” : GPIO1 Output mode

Refer to “●General-purpose I/O Ports (GPIO1-GPIO4)” for detail.

Address 21h < GPIO output mode >

Address	R/W	Bit7	Bit6	Bit5	Bit4	Bit3	Bit2	Bit1	Bit0
21h	W	GPO1OSC	-	-	KBOD	GPO4OD	GPO3OD	GPO2OD	GPO1OD
Initial Value	00h	0	-	-	0	0	0	0	0

Bit7 : **GPO1OSC** GPIO1 Mode Setting (Input / Output)
 "0" : Illumination Reference Clock OFF (Initial value)
 "1" : Illumination Reference Clock ON
 Refer to "6. Clock external output" of "●RGB Waveform Setting" for detail.

Bit [6:5] : (Not used)

Bit4 : **KBOD** KBLT Output Mode Setting (Open Drain / Complementary)
 "0" : KBLT GPO Output Open Drain (Initial value)
 "1" : KBLT GPO Output Complementary
 Refer to "●Key Backlight Controller" for detail.

Bit3 : **GPO4OD** GPIO4 Output Mode Setting (Open Drain / Complementary)
 "0" : GPIO4 GPO Output Open Drain (Initial value)
 "1" : GPIO4 GPO Output Complementary
 Refer to "●General-purpose I/O Ports (GPIO1-GPIO4)" for detail.

Bit2 : **GPO3OD** GPIO3 Output Mode Setting (Open Drain / Complementary)
 "0" : GPIO3 GPO Output Open Drain (Initial value)
 "1" : GPIO3 GPO Output Complementary
 Refer to "●General-purpose I/O Ports (GPIO1-GPIO4)" for detail.

Bit1 : **GPO2OD** GPIO2 Output Mode Setting (Open Drain / Complementary)
 "0" : GPIO2 GPO Output Open Drain (Initial value)
 "1" : GPIO2 GPO Output Complementary
 Refer to "●General-purpose I/O Ports (GPIO1-GPIO4)" for detail.

Bit0 : **GPO1OD** GPIO1 Output Mode Setting (Open Drain / Complementary)
 "0" : GPIO1 GPO Output Open Drain (Initial value)
 "1" : GPIO1 GPO Output Complementary
 Refer to "●General-purpose I/O Ports (GPIO1-GPIO4)" for detail.

Address 22h < GPIO output data >

Address	R/W	Bit7	Bit6	Bit5	Bit4	Bit3	Bit2	Bit1	Bit0
22h	W	B2LV	G2LV	R2LV	-	GPO4LV	GPO3LV	GPO2LV	GPO1LV
Initial Value	00h	0	0	0	-	0	0	0	0

- Bit7 : **B2LV** B2LED Output Setting at GPO mode (Low / High)
 "0" : Output Low (Initial value)
 "1" : Output High
 Refer to "●General-purpose I/O Ports (GPIO1-GPIO4)" for detail.
- Bit6 : **G2LV** G2LED Output Setting at GPO mode (Low / High)
 "0" : Output Low (Initial value)
 "1" : Output High
 Refer to "●General-purpose I/O Ports (GPIO1-GPIO4)" for detail.
- Bit5 : **R2LV** R2LED Output Setting at GPO mode (Low / High)
 "0" : Output Low (Initial value)
 "1" : Output High
 Refer to "●General-purpose I/O Ports (GPIO1-GPIO4)" for detail.
- Bit4 : (Not used)
- Bit3 : **GPO4LV** GPIO4 Output Setting at Output mode (Low / High)
 "0" : Output Low (Initial value)
 "1" : Output High
 Refer to "●General-purpose I/O Ports (GPIO1-GPIO4)" for detail.
- Bit2 : **GPO3LV** GPIO3 Output Setting at Output mode (Low / High)
 "0" : Output Low (Initial value)
 "1" : Output High
 Refer to "●General-purpose I/O Ports (GPIO1-GPIO4)" for detail.
- Bit1 : **GPO2LV** GPIO2 Output Setting at Output mode (Low / High)
 "0" : Output Low (Initial value)
 "1" : Output High
 Refer to "●General-purpose I/O Ports (GPIO1-GPIO4)" for detail.
- Bit0 : **GPO1LV** GPIO1 Output Setting at Output mode (Low / High)
 "0" : Output Low (Initial value)
 "1" : Output High
 Refer to "●General-purpose I/O Ports (GPIO1-GPIO4)" for detail.

Address 23h < GPIO Interrupt mask setup >

Address	R/W	Bit7	Bit6	Bit5	Bit4	Bit3	Bit2	Bit1	Bit0
23h	W	GPCLR	-	-	-	GP4MSK	GP3MSK	GP2MSK	GP1MSK
Initial Value	00h	0	-	-	-	0	0	0	0

Bit7 : **GPCLR** GPIO Clear Setting
 "0" : No operate
 "1" : GPIO Interrupt Factor Clear
 Refer to "●General-purpose I/O Ports (GPIO1-GPIO4)" for detail.

Bit [6:4] : (Not used)

Bit3 : **GP4MSK** GPIO4 Interrupt Mask Setting
 "0" : GPIO4 Interrupt Mask (Initial value)
 "1" : GPIO4 Interrupt Non-mask
 Refer to "●General-purpose I/O Ports (GPIO1-GPIO4)" for detail.

Bit2 : **GP3MSK** GPIO3 Interrupt Mask Setting
 "0" : GPIO3 Interrupt Mask (Initial value)
 "1" : GPIO3 Interrupt Non-mask
 Refer to "●General-purpose I/O Ports (GPIO1-GPIO4)" for detail.

Bit1 : **GP2MSK** GPIO2 Interrupt Mask Setting
 "0" : GPIO2 Interrupt Mask (Initial value)
 "1" : GPIO2 Interrupt Non-mask
 Refer to "●General-purpose I/O Ports (GPIO1-GPIO4)" for detail.

Bit0 : **GP1MSK** GPIO1 Interrupt Mask Setting
 "0" : GPIO1 Interrupt Mask (Initial value)
 "1" : GPIO1 Interrupt Non-mask
 Refer to "●General-purpose I/O Ports (GPIO1-GPIO4)" for detail.

Address 24h < GPIO Interput factor read out, Data read out >

Address	R/W	Bit7	Bit6	Bit5	Bit4	Bit3	Bit2	Bit1	Bit0
24h	R	GP4INT	GP3INT	GP2INT	GP1INT	GP4DAT	GP3DAT	GP2DAT	GP1DAT
Initial Value	00h	0	0	0	0	-	-	-	-

- Bit7 : **GP4INT** GPIO4 Interrupt factor read out
 "0" : No Input by GPIO4
 "1" : Input by GPIO4
 Refer to "●General-purpose I/O Ports (GPIO1-GPIO4)" for detail.
- Bit6 : **GP3INT** GPIO3 Interrupt factor read out
 "0" : No Input by GPIO3
 "1" : Input by GPIO3
 Refer to "●General-purpose I/O Ports (GPIO1-GPIO4)" for detail.
- Bit5 : **GP2INT** GPIO2 Interrupt factor read out
 "0" : No Input by GPIO2
 "1" : Input by GPIO2
 Refer to "●General-purpose I/O Ports (GPIO1-GPIO4)" for detail.
- Bit4 : **GP1INT** GPIO1 Interrupt factor read out
 "0" : No Input by GPIO1
 "1" : Input by GPIO1
 Refer to "●General-purpose I/O Ports (GPIO1-GPIO4)" for detail.
- Bit3 : **GP4DAT** GPIO4 Data read out
 "0" : GPIO4 is Low
 "1" : GPIO4 is Hight
 Refer to "●General-purpose I/O Ports (GPIO1-GPIO4)" for detail.
- Bit2 : **GP3DAT** GPIO3 Data read out
 "0" : GPIO3 is Low
 "1" : GPIO3 is Hight
 Refer to "●General-purpose I/O Ports (GPIO1-GPIO4)" for detail.
- Bit1 : **GP2DAT** GPIO2 Data read out
 "0" : GPIO2 is Low
 "1" : GPIO2 is Hight
 Refer to "●General-purpose I/O Ports (GPIO1-GPIO4)" for detail.
- Bit0 : **GP1DAT** GPIO1 Data read out
 "0" : GPIO1 is Low
 "1" : GPIO1 is Hight
 Refer to "●General-purpose I/O Ports (GPIO1-GPIO4)" for detail.

Address 25h < RGB LED control >

Address	R/W	Bit7	Bit6	Bit5	Bit4	Bit3	Bit2	Bit1	Bit0
25h	W	-	RGB2MEL	RGB2OS	RGB2EN	-	RGB1MEL	RGB1OS	RGB1EN
Initial Value	00h	-	0	0	0	-	0	0	0

Bit7 : (Not used)

Bit6 : **RGB2MEL** RGB2 External Control Setting

“0” : RGB2 External Control Invalid (Initial value)

“1” : RGB2 External Control Valid

Refer to “5. External terminal synchronization control” of “●RGB Waveform Setting” for detail.

Bit5 : **RGB2OS** RGB2 One shot enable

“0” : RGB2 Stop (Initial value)

“1” : RGB2 1periodic Operation

Refer to “8. RGB slope waveforms” of “●RGB Waveform Setting” for detail.

Refer to “●Description of DC/DC Operations” for detail.

Bit4 : **RGB2EN** RGB2 Enable

“0” : RGB2 Stop (Initial value)

“1” : RGB2 Continuous Operation

Refer to “8. RGB slope waveforms” of “●RGB Waveform Setting” for detail.

Refer to “●Description of DC/DC Operations” for detail.

Bit3 : (Not used)

Bit2 : **RGB1MEL** RGB1 External Control Setting

“0” : RGB1 External Control Invalid (Initial value)

“1” : RGB1 External Control Valid

Refer to “5. External terminal synchronization control” of “●RGB Waveform Setting” for detail.

Bit1 : **RGB1OS** RGB1 One shot enable

“0” : RGB1 Stop (Initial value)

“1” : RGB1 1periodic Operation

Refer to “8. RGB slope waveforms” of “●RGB Waveform Setting” for detail.

Refer to “●Description of DC/DC Operations” for detail.

Bit0 : **RGB1EN** RGB1 Enable

“0” : RGB1 Stop (Initial value)

“1” : RGB1 Continuous Operation

Refer to “8. RGB slope waveforms” of “●RGB Waveform Setting” for detail.

Refer to “●Description of DC/DC Operations” for detail.

RGB*OS returns to 0 automatically after 1 cycle operation.

RGB*EN precedes to RGB*OS. In use in 1 cycle operation, there is the necessity for RGB*EN=0.

Address 26h < RGB1 time >

Address	R/W	Bit7	Bit6	Bit5	Bit4	Bit3	Bit2	Bit1	Bit0
26h	W	SFRGB1(1)	SFRGB1(0)	SRRGB1(1)	SRRGB1(0)	-	TRGB1(2)	TRGB1(1)	TRGB1(0)
Initial Value	00h	0	0	0	0	-	0	0	0

Bit [7:6] : **SFRGB1(1:0)** Slope Down Transition Setting

- "00" : 0
- "01" : Wave form cycle / 16
- "10" : Wave form cycle / 8
- "11" : Wave form cycle / 4

It is a theoretical value on logic control, and the reaction time of the analog section is not included.
 "Slope time" is the time from a slope start to a slope end.

Refer to "4. Rising/falling slope time" of "●RGB Waveform Setting" for detail.

Bit [5:4] : **SRRGB1(1:0)** Slope Up Transition Setting

- "00" : 0
- "01" : Wave form cycle / 16
- "10" : Wave form cycle / 8
- "11" : Wave form cycle / 4

It is a theoretical value on logic control, and the reaction time of the analog section is not included.
 "Slope time" is the time from a slope start to a slope end.

Refer to "4. Rising/falling slope time" of "●RGB Waveform Setting" for detail.

Bit3 : (Not used)

Bit [2:0] : **TRGB1(2:0)** Wave Form Cycle Setting

- "000" : 0.131 s
- "001" : 0.52 s
- "010" : 1.05 s
- "011" : 2.10 s
- "100" : 4.19 s
- "101" : 8.39 s
- "110" : 12.6 s
- "111" : 16.8 s

Refer to "1. Waveform cycle" of "●RGB Waveform Setting" for detail.

Address 27h < R1 current1 setup >

Address	R/W	Bit7	Bit6	Bit5	Bit4	Bit3	Bit2	Bit1	Bit0
27h	W	-	IR11(6)	IR11(5)	IR11(4)	IR11(3)	IR11(2)	IR11(1)	IR11(0)
Initial Value	00h	-	0	0	0	0	0	0	0

Bit7 : (Not used)

Bit [6:0] : **IR11(6:0)** R1LED Current1 Setting (At RGBISETpin 120kΩ connection)

"0000000" : 0.0 mA	"0110010" : 10.0mA	"1100100" : 20.0mA
"0000001" : 0.2 mA	"0110011" : 10.2mA	"1100101" : 20.2mA
"0000010" : 0.4 mA	"0110100" : 10.4mA	"1100110" : 20.4mA
"0000011" : 0.6 mA	"0110101" : 10.6mA	"1100111" : 20.6mA
"0000100" : 0.8 mA	"0110110" : 10.8mA	"1101000" : 20.8mA
"0000101" : 1.0 mA	"0110111" : 11.0mA	"1101001" : 21.0mA
"0000110" : 1.2 mA	"0111000" : 11.2mA	"1101010" : 21.2mA
"0000111" : 1.4 mA	"0111001" : 11.4mA	"1101011" : 21.4mA
"0001000" : 1.6 mA	"0111010" : 11.6mA	"1101100" : 21.6mA
"0001001" : 1.8 mA	"0111011" : 11.8mA	"1101101" : 21.8mA
"0001010" : 2.0 mA	"0111100" : 12.0mA	"1101110" : 22.0mA
"0001011" : 2.2 mA	"0111101" : 12.2mA	"1101111" : 22.2mA
"0001100" : 2.4 mA	"0111110" : 12.4mA	"1110000" : 22.4mA
"0001101" : 2.6 mA	"0111111" : 12.6mA	"1110001" : 22.6mA
"0001110" : 2.8 mA	"1000000" : 12.8mA	"1110010" : 22.8mA
"0001111" : 3.0 mA	"1000001" : 13.0mA	"1110011" : 23.0mA
"0010000" : 3.2 mA	"1000010" : 13.2mA	"1110100" : 23.2mA
"0010001" : 3.4 mA	"1000011" : 13.4mA	"1110101" : 23.4mA
"0010010" : 3.6 mA	"1000100" : 13.6mA	"1110110" : 23.6mA
"0010011" : 3.8 mA	"1000101" : 13.8mA	"1110111" : 23.8mA
"0010100" : 4.0 mA	"1000110" : 14.0mA	"1111000" : 24.0mA
"0010101" : 4.2 mA	"1000111" : 14.2mA	"1111001" : 24.2mA
"0010110" : 4.4 mA	"1001000" : 14.4mA	"1111010" : 24.4mA
"0010111" : 4.6 mA	"1001001" : 14.6mA	"1111011" : 24.6mA
"0011000" : 4.8 mA	"1001010" : 14.8mA	"1111100" : 24.8mA
"0011001" : 5.0 mA	"1001011" : 15.0mA	"1111101" : 25.0mA
"0011010" : 5.2 mA	"1001100" : 15.2mA	"1111110" : 25.2mA
"0011011" : 5.4 mA	"1001101" : 15.4mA	"1111111" : 25.4mA
"0011100" : 5.6 mA	"1001110" : 15.6mA	
"0011101" : 5.8 mA	"1001111" : 15.8mA	
"0011110" : 6.0 mA	"1010000" : 16.0mA	
"0011111" : 6.2 mA	"1010001" : 16.2mA	
"0100000" : 6.4 mA	"1010010" : 16.4mA	
"0100001" : 6.6 mA	"1010011" : 16.6mA	
"0100010" : 6.8 mA	"1010100" : 16.8mA	
"0100011" : 7.0 mA	"1010101" : 17.0mA	
"0100100" : 7.2 mA	"1010110" : 17.2mA	
"0100101" : 7.4 mA	"1010111" : 17.4mA	
"0100110" : 7.6 mA	"1011000" : 17.6mA	
"0100111" : 7.8 mA	"1011001" : 17.8mA	
"0101000" : 8.0 mA	"1011010" : 18.0mA	
"0101001" : 8.2 mA	"1011011" : 18.2mA	
"0101010" : 8.4 mA	"1011100" : 18.4mA	
"0101011" : 8.6 mA	"1011101" : 18.6mA	
"0101100" : 8.8 mA	"1011110" : 18.8mA	
"0101101" : 9.0 mA	"1011111" : 19.0mA	
"0101110" : 9.2 mA	"1100000" : 19.2mA	
"0101111" : 9.4 mA	"1100001" : 19.4mA	
"0110000" : 9.6 mA	"1100010" : 19.6mA	
"0110001" : 9.8 mA	"1100011" : 19.8mA	

Refer to "3. Current settings 1 and 2 (I1, I2)" of "●RGB Waveform Setting" for detail.

Address 28h < R1 current2 setup>

Address	R/W	Bit7	Bit6	Bit5	Bit4	Bit3	Bit2	Bit1	Bit0
28h	W	-	IR12(6)	IR12(5)	IR12(4)	IR12(3)	IR12(2)	IR12(1)	IR12(0)
Initial Value	00h	-	0	0	0	0	0	0	0

Bit7 : (Not used)

Bit [6:0] : **IR12(6:0)** R1LED Current2 Setting (At RGBSETpin 120kΩ connection)

"0000000" : 0.0 mA	"0110010" : 10.0mA	"1100100" : 20.0mA
"0000001" : 0.2 mA	"0110011" : 10.2mA	"1100101" : 20.2mA
"0000010" : 0.4 mA	"0110100" : 10.4mA	"1100110" : 20.4mA
"0000011" : 0.6 mA	"0110101" : 10.6mA	"1100111" : 20.6mA
"0000100" : 0.8 mA	"0110110" : 10.8mA	"1101000" : 20.8mA
"0000101" : 1.0 mA	"0110111" : 11.0mA	"1101001" : 21.0mA
"0000110" : 1.2 mA	"0111000" : 11.2mA	"1101010" : 21.2mA
"0000111" : 1.4 mA	"0111001" : 11.4mA	"1101011" : 21.4mA
"0001000" : 1.6 mA	"0111010" : 11.6mA	"1101100" : 21.6mA
"0001001" : 1.8 mA	"0111011" : 11.8mA	"1101101" : 21.8mA
"0001010" : 2.0 mA	"0111100" : 12.0mA	"1101110" : 22.0mA
"0001011" : 2.2 mA	"0111101" : 12.2mA	"1101111" : 22.2mA
"0001100" : 2.4 mA	"0111110" : 12.4mA	"1110000" : 22.4mA
"0001101" : 2.6 mA	"0111111" : 12.6mA	"1110001" : 22.6mA
"0001110" : 2.8 mA	"1000000" : 12.8mA	"1110010" : 22.8mA
"0001111" : 3.0 mA	"1000001" : 13.0mA	"1110011" : 23.0mA
"0010000" : 3.2 mA	"1000010" : 13.2mA	"1110100" : 23.2mA
"0010001" : 3.4 mA	"1000011" : 13.4mA	"1110101" : 23.4mA
"0010010" : 3.6 mA	"1000100" : 13.6mA	"1110110" : 23.6mA
"0010011" : 3.8 mA	"1000101" : 13.8mA	"1110111" : 23.8mA
"0010100" : 4.0 mA	"1000110" : 14.0mA	"1111000" : 24.0mA
"0010101" : 4.2 mA	"1000111" : 14.2mA	"1111001" : 24.2mA
"0010110" : 4.4 mA	"1001000" : 14.4mA	"1111010" : 24.4mA
"0010111" : 4.6 mA	"1001001" : 14.6mA	"1111011" : 24.6mA
"0011000" : 4.8 mA	"1001010" : 14.8mA	"1111100" : 24.8mA
"0011001" : 5.0 mA	"1001011" : 15.0mA	"1111101" : 25.0mA
"0011010" : 5.2 mA	"1001100" : 15.2mA	"1111110" : 25.2mA
"0011011" : 5.4 mA	"1001101" : 15.4mA	"1111111" : 25.4mA
"0011100" : 5.6 mA	"1001110" : 15.6mA	
"0011101" : 5.8 mA	"1001111" : 15.8mA	
"0011110" : 6.0 mA	"1010000" : 16.0mA	
"0011111" : 6.2 mA	"1010001" : 16.2mA	
"0100000" : 6.4 mA	"1010010" : 16.4mA	
"0100001" : 6.6 mA	"1010011" : 16.6mA	
"0100010" : 6.8 mA	"1010100" : 16.8mA	
"0100011" : 7.0 mA	"1010101" : 17.0mA	
"0100100" : 7.2 mA	"1010110" : 17.2mA	
"0100101" : 7.4 mA	"1010111" : 17.4mA	
"0100110" : 7.6 mA	"1011000" : 17.6mA	
"0100111" : 7.8 mA	"1011001" : 17.8mA	
"0101000" : 8.0 mA	"1011010" : 18.0mA	
"0101001" : 8.2 mA	"1011011" : 18.2mA	
"0101010" : 8.4 mA	"1011100" : 18.4mA	
"0101011" : 8.6 mA	"1011101" : 18.6mA	
"0101100" : 8.8 mA	"1011110" : 18.8mA	
"0101101" : 9.0 mA	"1011111" : 19.0mA	
"0101110" : 9.2 mA	"1100000" : 19.2mA	
"0101111" : 9.4 mA	"1100001" : 19.4mA	
"0110000" : 9.6 mA	"1100010" : 19.6mA	
"0110001" : 9.8 mA	"1100011" : 19.8mA	

Refer to "3. Current settings 1 and 2 (I1, I2)" of "●RGB Waveform Setting" for detail.

Address 29h < R1 Wave Pattern>

Address	R/W	Bit7	Bit6	Bit5	Bit4	Bit3	Bit2	Bit1	Bit0
29h	W	-	-	-	-	PR1(3)	PR1(2)	PR1(1)	PR1(0)
Initial Value	07h	-	-	-	-	0	1	1	1

Bit [7:4] : (Not used)

Bit [3:0] : **PR1(3:0)** R1LED Wave Pattern

"0000" : Pattern 1
 "0001" : Pattern 2
 "0010" : Pattern 3
 "0011" : Pattern 4
 "0100" : Pattern 5
 "0101" : Pattern 6
 "0110" : Pattern 7
 "0111" : Pattern 8
 "1000" : Pattern 9
 "1001" : Pattern 10
 "1010" : Pattern 11
 "1011" : Pattern 12
 "1100" : Pattern 13
 "1101" : Pattern 14
 "1110" : Pattern 15
 "1111" : Pattern 16

Refer to "2. Waveform pattern" of "●RGB Waveform Setting" for detail.

Address 2Ah < G1 current1 setup>

Address	R/W	Bit7	Bit6	Bit5	Bit4	Bit3	Bit2	Bit1	Bit0
2Ah	W	-	IG11(6)	IG11(5)	IG11(4)	IG11(3)	IG11(2)	IG11(1)	IG11(0)
Initial Value	00h	-	0	0	0	0	0	0	0

Bit7 : (Not used)

Bit [6:0] : **IG11(6:0)** G1LED Current1 Setting (At RGBISETpin 120kΩ connection)

"0000000" : 0.0 mA	"0110010" : 10.0mA	"1100100" : 20.0mA
"0000001" : 0.2 mA	"0110011" : 10.2mA	"1100101" : 20.2mA
"0000010" : 0.4 mA	"0110100" : 10.4mA	"1100110" : 20.4mA
"0000011" : 0.6 mA	"0110101" : 10.6mA	"1100111" : 20.6mA
"0000100" : 0.8 mA	"0110110" : 10.8mA	"1101000" : 20.8mA
"0000101" : 1.0 mA	"0110111" : 11.0mA	"1101001" : 21.0mA
"0000110" : 1.2 mA	"0111000" : 11.2mA	"1101010" : 21.2mA
"0000111" : 1.4 mA	"0111001" : 11.4mA	"1101011" : 21.4mA
"0001000" : 1.6 mA	"0111010" : 11.6mA	"1101100" : 21.6mA
"0001001" : 1.8 mA	"0111011" : 11.8mA	"1101101" : 21.8mA
"0001010" : 2.0 mA	"0111100" : 12.0mA	"1101110" : 22.0mA
"0001011" : 2.2 mA	"0111101" : 12.2mA	"1101111" : 22.2mA
"0001100" : 2.4 mA	"0111110" : 12.4mA	"1110000" : 22.4mA
"0001101" : 2.6 mA	"0111111" : 12.6mA	"1110001" : 22.6mA
"0001110" : 2.8 mA	"1000000" : 12.8mA	"1110010" : 22.8mA
"0001111" : 3.0 mA	"1000001" : 13.0mA	"1110011" : 23.0mA
"0010000" : 3.2 mA	"1000010" : 13.2mA	"1110100" : 23.2mA
"0010001" : 3.4 mA	"1000011" : 13.4mA	"1110101" : 23.4mA
"0010010" : 3.6 mA	"1000100" : 13.6mA	"1110110" : 23.6mA
"0010011" : 3.8 mA	"1000101" : 13.8mA	"1110111" : 23.8mA
"0010100" : 4.0 mA	"1000110" : 14.0mA	"1111000" : 24.0mA
"0010101" : 4.2 mA	"1000111" : 14.2mA	"1111001" : 24.2mA
"0010110" : 4.4 mA	"1001000" : 14.4mA	"1111010" : 24.4mA
"0010111" : 4.6 mA	"1001001" : 14.6mA	"1111011" : 24.6mA
"0011000" : 4.8 mA	"1001010" : 14.8mA	"1111100" : 24.8mA
"0011001" : 5.0 mA	"1001011" : 15.0mA	"1111101" : 25.0mA
"0011010" : 5.2 mA	"1001100" : 15.2mA	"1111110" : 25.2mA
"0011011" : 5.4 mA	"1001101" : 15.4mA	"1111111" : 25.4mA
"0011100" : 5.6 mA	"1001110" : 15.6mA	
"0011101" : 5.8 mA	"1001111" : 15.8mA	
"0011110" : 6.0 mA	"1010000" : 16.0mA	
"0011111" : 6.2 mA	"1010001" : 16.2mA	
"0100000" : 6.4 mA	"1010010" : 16.4mA	
"0100001" : 6.6 mA	"1010011" : 16.6mA	
"0100010" : 6.8 mA	"1010100" : 16.8mA	
"0100011" : 7.0 mA	"1010101" : 17.0mA	
"0100100" : 7.2 mA	"1010110" : 17.2mA	
"0100101" : 7.4 mA	"1010111" : 17.4mA	
"0100110" : 7.6 mA	"1011000" : 17.6mA	
"0100111" : 7.8 mA	"1011001" : 17.8mA	
"0101000" : 8.0 mA	"1011010" : 18.0mA	
"0101001" : 8.2 mA	"1011011" : 18.2mA	
"0101010" : 8.4 mA	"1011100" : 18.4mA	
"0101011" : 8.6 mA	"1011101" : 18.6mA	
"0101100" : 8.8 mA	"1011110" : 18.8mA	
"0101101" : 9.0 mA	"1011111" : 19.0mA	
"0101110" : 9.2 mA	"1100000" : 19.2mA	
"0101111" : 9.4 mA	"1100001" : 19.4mA	
"0110000" : 9.6 mA	"1100010" : 19.6mA	
"0110001" : 9.8 mA	"1100011" : 19.8mA	

Refer to "3. Current settings 1 and 2 (I1, I2)" of "●RGB Waveform Setting" for detail.

Address 2Bh < G1 current2 setup>

Address	R/W	Bit7	Bit6	Bit5	Bit4	Bit3	Bit2	Bit1	Bit0
2Bh	W	-	IG12(6)	IG12(5)	IG12(4)	IG12(3)	IG12(2)	IG12(1)	IG12(0)
Initial Value	00h	-	0	0	0	0	0	0	0

Bit7 : (Not used)

Bit [6:0] : **IG12(6:0)** G1LED Current2 Setting (At RGBSETpin 120kΩ connection)

"0000000" : 0.0 mA	"0110010" : 10.0mA	"1100100" : 20.0mA
"0000001" : 0.2 mA	"0110011" : 10.2mA	"1100101" : 20.2mA
"0000010" : 0.4 mA	"0110100" : 10.4mA	"1100110" : 20.4mA
"0000011" : 0.6 mA	"0110101" : 10.6mA	"1100111" : 20.6mA
"0000100" : 0.8 mA	"0110110" : 10.8mA	"1101000" : 20.8mA
"0000101" : 1.0 mA	"0110111" : 11.0mA	"1101001" : 21.0mA
"0000110" : 1.2 mA	"0111000" : 11.2mA	"1101010" : 21.2mA
"0000111" : 1.4 mA	"0111001" : 11.4mA	"1101011" : 21.4mA
"0001000" : 1.6 mA	"0111010" : 11.6mA	"1101100" : 21.6mA
"0001001" : 1.8 mA	"0111011" : 11.8mA	"1101101" : 21.8mA
"0001010" : 2.0 mA	"0111100" : 12.0mA	"1101110" : 22.0mA
"0001011" : 2.2 mA	"0111101" : 12.2mA	"1101111" : 22.2mA
"0001100" : 2.4 mA	"0111110" : 12.4mA	"1110000" : 22.4mA
"0001101" : 2.6 mA	"0111111" : 12.6mA	"1110001" : 22.6mA
"0001110" : 2.8 mA	"1000000" : 12.8mA	"1110010" : 22.8mA
"0001111" : 3.0 mA	"1000001" : 13.0mA	"1110011" : 23.0mA
"0010000" : 3.2 mA	"1000010" : 13.2mA	"1110100" : 23.2mA
"0010001" : 3.4 mA	"1000011" : 13.4mA	"1110101" : 23.4mA
"0010010" : 3.6 mA	"1000100" : 13.6mA	"1110110" : 23.6mA
"0010011" : 3.8 mA	"1000101" : 13.8mA	"1110111" : 23.8mA
"0010100" : 4.0 mA	"1000110" : 14.0mA	"1111000" : 24.0mA
"0010101" : 4.2 mA	"1000111" : 14.2mA	"1111001" : 24.2mA
"0010110" : 4.4 mA	"1001000" : 14.4mA	"1111010" : 24.4mA
"0010111" : 4.6 mA	"1001001" : 14.6mA	"1111011" : 24.6mA
"0011000" : 4.8 mA	"1001010" : 14.8mA	"1111100" : 24.8mA
"0011001" : 5.0 mA	"1001011" : 15.0mA	"1111101" : 25.0mA
"0011010" : 5.2 mA	"1001100" : 15.2mA	"1111110" : 25.2mA
"0011011" : 5.4 mA	"1001101" : 15.4mA	"1111111" : 25.4mA
"0011100" : 5.6 mA	"1001110" : 15.6mA	
"0011101" : 5.8 mA	"1001111" : 15.8mA	
"0011110" : 6.0 mA	"1010000" : 16.0mA	
"0011111" : 6.2 mA	"1010001" : 16.2mA	
"0100000" : 6.4 mA	"1010010" : 16.4mA	
"0100001" : 6.6 mA	"1010011" : 16.6mA	
"0100010" : 6.8 mA	"1010100" : 16.8mA	
"0100011" : 7.0 mA	"1010101" : 17.0mA	
"0100100" : 7.2 mA	"1010110" : 17.2mA	
"0100101" : 7.4 mA	"1010111" : 17.4mA	
"0100110" : 7.6 mA	"1011000" : 17.6mA	
"0100111" : 7.8 mA	"1011001" : 17.8mA	
"0101000" : 8.0 mA	"1011010" : 18.0mA	
"0101001" : 8.2 mA	"1011011" : 18.2mA	
"0101010" : 8.4 mA	"1011100" : 18.4mA	
"0101011" : 8.6 mA	"1011101" : 18.6mA	
"0101100" : 8.8 mA	"1011110" : 18.8mA	
"0101101" : 9.0 mA	"1011111" : 19.0mA	
"0101110" : 9.2 mA	"1100000" : 19.2mA	
"0101111" : 9.4 mA	"1100001" : 19.4mA	
"0110000" : 9.6 mA	"1100010" : 19.6mA	
"0110001" : 9.8 mA	"1100011" : 19.8mA	

Refer to "3. Current settings 1 and 2 (I1, I2)" of "●RGB Waveform Setting" for detail.

Address 2Ch < G1 Wave pattern >

Address	R/W	Bit7	Bit6	Bit5	Bit4	Bit3	Bit2	Bit1	Bit0
2Ch	W	-	-	-	-	PG1(3)	PG1(2)	PG1(1)	PG1(0)
Initial Value	07h	-	-	-	-	0	1	1	1

Bit [7:4] : (Not used)

Bit [3:0] : **PG1(3:0)** G1LED Wave Pattern

"0000" : Pattern 1
 "0001" : Pattern 2
 "0010" : Pattern 3
 "0011" : Pattern 4
 "0100" : Pattern 5
 "0101" : Pattern 6
 "0110" : Pattern 7
 "0111" : Pattern 8
 "1000" : Pattern 9
 "1001" : Pattern 10
 "1010" : Pattern 11
 "1011" : Pattern 12
 "1100" : Pattern 13
 "1101" : Pattern 14
 "1110" : Pattern 15
 "1111" : Pattern 16

Refer to "2. Waveform pattern" of "•RGB Waveform Setting" for detail.

Address 2Dh < B1 current1 setup >

Address	R/W	Bit7	Bit6	Bit5	Bit4	Bit3	Bit2	Bit1	Bit0
2Dh	W	-	IB11(6)	IB11(5)	IB11(4)	IB11(3)	IB11(2)	IB11(1)	IB11(0)
Initial Value	00h	-	0	0	0	0	0	0	0

Bit7 : (Not used)

Bit [6:0] : **IB11(6:0)** B1LED Current1 Setting (At RGBISETpin 120kΩ connection)

"0000000" : 0.0 mA	"0110010" : 10.0mA	"1100100" : 20.0mA
"0000001" : 0.2 mA	"0110011" : 10.2mA	"1100101" : 20.2mA
"0000010" : 0.4 mA	"0110100" : 10.4mA	"1100110" : 20.4mA
"0000011" : 0.6 mA	"0110101" : 10.6mA	"1100111" : 20.6mA
"0000100" : 0.8 mA	"0110110" : 10.8mA	"1101000" : 20.8mA
"0000101" : 1.0 mA	"0110111" : 11.0mA	"1101001" : 21.0mA
"0000110" : 1.2 mA	"0111000" : 11.2mA	"1101010" : 21.2mA
"0000111" : 1.4 mA	"0111001" : 11.4mA	"1101011" : 21.4mA
"0001000" : 1.6 mA	"0111010" : 11.6mA	"1101100" : 21.6mA
"0001001" : 1.8 mA	"0111011" : 11.8mA	"1101101" : 21.8mA
"0001010" : 2.0 mA	"0111100" : 12.0mA	"1101110" : 22.0mA
"0001011" : 2.2 mA	"0111101" : 12.2mA	"1101111" : 22.2mA
"0001100" : 2.4 mA	"0111110" : 12.4mA	"1110000" : 22.4mA
"0001101" : 2.6 mA	"0111111" : 12.6mA	"1110001" : 22.6mA
"0001110" : 2.8 mA	"1000000" : 12.8mA	"1110010" : 22.8mA
"0001111" : 3.0 mA	"1000001" : 13.0mA	"1110011" : 23.0mA
"0010000" : 3.2 mA	"1000010" : 13.2mA	"1110100" : 23.2mA
"0010001" : 3.4 mA	"1000011" : 13.4mA	"1110101" : 23.4mA
"0010010" : 3.6 mA	"1000100" : 13.6mA	"1110110" : 23.6mA
"0010011" : 3.8 mA	"1000101" : 13.8mA	"1110111" : 23.8mA
"0010100" : 4.0 mA	"1000110" : 14.0mA	"1111000" : 24.0mA
"0010101" : 4.2 mA	"1000111" : 14.2mA	"1111001" : 24.2mA
"0010110" : 4.4 mA	"1001000" : 14.4mA	"1111010" : 24.4mA
"0010111" : 4.6 mA	"1001001" : 14.6mA	"1111011" : 24.6mA
"0011000" : 4.8 mA	"1001010" : 14.8mA	"1111100" : 24.8mA
"0011001" : 5.0 mA	"1001011" : 15.0mA	"1111101" : 25.0mA
"0011010" : 5.2 mA	"1001100" : 15.2mA	"1111110" : 25.2mA
"0011011" : 5.4 mA	"1001101" : 15.4mA	"1111111" : 25.4mA
"0011100" : 5.6 mA	"1001110" : 15.6mA	
"0011101" : 5.8 mA	"1001111" : 15.8mA	
"0011110" : 6.0 mA	"1010000" : 16.0mA	
"0011111" : 6.2 mA	"1010001" : 16.2mA	
"0100000" : 6.4 mA	"1010010" : 16.4mA	
"0100001" : 6.6 mA	"1010011" : 16.6mA	
"0100010" : 6.8 mA	"1010100" : 16.8mA	
"0100011" : 7.0 mA	"1010101" : 17.0mA	
"0100100" : 7.2 mA	"1010110" : 17.2mA	
"0100101" : 7.4 mA	"1010111" : 17.4mA	
"0100110" : 7.6 mA	"1011000" : 17.6mA	
"0100111" : 7.8 mA	"1011001" : 17.8mA	
"0101000" : 8.0 mA	"1011010" : 18.0mA	
"0101001" : 8.2 mA	"1011011" : 18.2mA	
"0101010" : 8.4 mA	"1011100" : 18.4mA	
"0101011" : 8.6 mA	"1011101" : 18.6mA	
"0101100" : 8.8 mA	"1011110" : 18.8mA	
"0101101" : 9.0 mA	"1011111" : 19.0mA	
"0101110" : 9.2 mA	"1100000" : 19.2mA	
"0101111" : 9.4 mA	"1100001" : 19.4mA	
"0110000" : 9.6 mA	"1100010" : 19.6mA	
"0110001" : 9.8 mA	"1100011" : 19.8mA	

Refer to "3. Current settings 1 and 2 (I1, I2)" of "●RGB Waveform Setting" for detail.

Address 2Eh < B1 current2 setup >

Address	R/W	Bit7	Bit6	Bit5	Bit4	Bit3	Bit2	Bit1	Bit0
2Eh	W	-	IB12(6)	IB12(5)	IB12(4)	IB12(3)	IB12(2)	IB12(1)	IB12(0)
Initial Value	00h	-	0	0	0	0	0	0	0

Bit7 : (Not used)

Bit [6:0] : **IB12(6:0)** B1LED Current2 Setting (At RGBISETpin 120kΩ connection)

"0000000" : 0.0 mA	"0110010" : 10.0mA	"1100100" : 20.0mA
"0000001" : 0.2 mA	"0110011" : 10.2mA	"1100101" : 20.2mA
"0000010" : 0.4 mA	"0110100" : 10.4mA	"1100110" : 20.4mA
"0000011" : 0.6 mA	"0110101" : 10.6mA	"1100111" : 20.6mA
"0000100" : 0.8 mA	"0110110" : 10.8mA	"1101000" : 20.8mA
"0000101" : 1.0 mA	"0110111" : 11.0mA	"1101001" : 21.0mA
"0000110" : 1.2 mA	"0111000" : 11.2mA	"1101010" : 21.2mA
"0000111" : 1.4 mA	"0111001" : 11.4mA	"1101011" : 21.4mA
"0001000" : 1.6 mA	"0111010" : 11.6mA	"1101100" : 21.6mA
"0001001" : 1.8 mA	"0111011" : 11.8mA	"1101101" : 21.8mA
"0001010" : 2.0 mA	"0111100" : 12.0mA	"1101110" : 22.0mA
"0001011" : 2.2 mA	"0111101" : 12.2mA	"1101111" : 22.2mA
"0001100" : 2.4 mA	"0111110" : 12.4mA	"1110000" : 22.4mA
"0001101" : 2.6 mA	"0111111" : 12.6mA	"1110001" : 22.6mA
"0001110" : 2.8 mA	"1000000" : 12.8mA	"1110010" : 22.8mA
"0001111" : 3.0 mA	"1000001" : 13.0mA	"1110011" : 23.0mA
"0010000" : 3.2 mA	"1000010" : 13.2mA	"1110100" : 23.2mA
"0010001" : 3.4 mA	"1000011" : 13.4mA	"1110101" : 23.4mA
"0010010" : 3.6 mA	"1000100" : 13.6mA	"1110110" : 23.6mA
"0010011" : 3.8 mA	"1000101" : 13.8mA	"1110111" : 23.8mA
"0010100" : 4.0 mA	"1000110" : 14.0mA	"1111000" : 24.0mA
"0010101" : 4.2 mA	"1000111" : 14.2mA	"1111001" : 24.2mA
"0010110" : 4.4 mA	"1001000" : 14.4mA	"1111010" : 24.4mA
"0010111" : 4.6 mA	"1001001" : 14.6mA	"1111011" : 24.6mA
"0011000" : 4.8 mA	"1001010" : 14.8mA	"1111100" : 24.8mA
"0011001" : 5.0 mA	"1001011" : 15.0mA	"1111101" : 25.0mA
"0011010" : 5.2 mA	"1001100" : 15.2mA	"1111110" : 25.2mA
"0011011" : 5.4 mA	"1001101" : 15.4mA	"1111111" : 25.4mA
"0011100" : 5.6 mA	"1001110" : 15.6mA	
"0011101" : 5.8 mA	"1001111" : 15.8mA	
"0011110" : 6.0 mA	"1010000" : 16.0mA	
"0011111" : 6.2 mA	"1010001" : 16.2mA	
"0100000" : 6.4 mA	"1010010" : 16.4mA	
"0100001" : 6.6 mA	"1010011" : 16.6mA	
"0100010" : 6.8 mA	"1010100" : 16.8mA	
"0100011" : 7.0 mA	"1010101" : 17.0mA	
"0100100" : 7.2 mA	"1010110" : 17.2mA	
"0100101" : 7.4 mA	"1010111" : 17.4mA	
"0100110" : 7.6 mA	"1011000" : 17.6mA	
"0100111" : 7.8 mA	"1011001" : 17.8mA	
"0101000" : 8.0 mA	"1011010" : 18.0mA	
"0101001" : 8.2 mA	"1011011" : 18.2mA	
"0101010" : 8.4 mA	"1011100" : 18.4mA	
"0101011" : 8.6 mA	"1011101" : 18.6mA	
"0101100" : 8.8 mA	"1011110" : 18.8mA	
"0101101" : 9.0 mA	"1011111" : 19.0mA	
"0101110" : 9.2 mA	"1100000" : 19.2mA	
"0101111" : 9.4 mA	"1100001" : 19.4mA	
"0110000" : 9.6 mA	"1100010" : 19.6mA	
"0110001" : 9.8 mA	"1100011" : 19.8mA	

Refer to "3. Current settings 1 and 2 (I1, I2)" of "●RGB Waveform Setting" for detail.

Address 2Fh < B1 Wave pattern >

Address	R/W	Bit7	Bit6	Bit5	Bit4	Bit3	Bit2	Bit1	Bit0
2Fh	W	-	-	-	-	PB1(3)	PB1(2)	PB1(1)	PB1(0)
Initial Value	07h	-	-	-	-	0	1	1	1

Bit [7:4] : (Not used)

Bit [3:0] : **PB1(3:0)** B1LED Wave Pattern

"0000" : Pattern 1
 "0001" : Pattern 2
 "0010" : Pattern 3
 "0011" : Pattern 4
 "0100" : Pattern 5
 "0101" : Pattern 6
 "0110" : Pattern 7
 "0111" : Pattern 8
 "1000" : Pattern 9
 "1001" : Pattern 10
 "1010" : Pattern 11
 "1011" : Pattern 12
 "1100" : Pattern 13
 "1101" : Pattern 14
 "1110" : Pattern 15
 "1111" : Pattern 16

Refer to "2. Waveform pattern" of "●RGB Waveform Setting" for detail.

Address 30h < RGB2 time >

Address	R/W	Bit7	Bit6	Bit5	Bit4	Bit3	Bit2	Bit1	Bit0
30h	W	SFRGB2(1)	SFRGB2(0)	SRRGB2(1)	SRRGB2(0)	-	TRGB2(2)	TRGB2(1)	TRGB2(0)
Initial Value	00h	-	-	0	0	0	0	0	0

Bit [7:6] : **SFRGB2(1:0)** Slope Down Transition Setting

- "00" : 0
- "01" : Wave form cycle / 16
- "10" : Wave form cycle / 8
- "11" : Wave form cycle / 4

It is a theoretical value on logic control, and the reaction time of the analog section is not included.
"Slope time" is the time from a slope start to a slope end.

Refer to "4. Rising/falling slope time" of "●RGB Waveform Setting" for detail.

Bit [5:4] : **SRRGB2(1:0)** Slope Up Transition Setting

- "00" : 0
- "01" : Wave form cycle / 16
- "10" : Wave form cycle / 8
- "11" : Wave form cycle / 4

It is a theoretical value on logic control, and the reaction time of the analog section is not included.
"Slope time" is the time from a slope start to a slope end.

Refer to "4. Rising/falling slope time" of "●RGB Waveform Setting" for detail.

Bit3 : (Not used)

Bit [2:0] : **TRGB2(2:0)** Wave Form Cycle Setting

- "000" : 0.131 s
- "001" : 0.52 s
- "010" : 1.05 s
- "011" : 2.10 s
- "100" : 4.19 s
- "101" : 8.39 s
- "110" : 12.6 s
- "111" : 16.8 s

Refer to "1. Waveform cycle" of "●RGB Waveform Setting" for detail.

Address 31h < R2 current 1setup >

Address	R/W	Bit7	Bit6	Bit5	Bit4	Bit3	Bit2	Bit1	Bit0
31h	W	-	IR21(6)	IR21(5)	IR21(4)	IR21(3)	IR21(2)	IR21(1)	IR21(0)
Initial Value	00h	-	-	0	0	0	0	0	0

Bit7 : (Not used)

Bit [6:0] : **IR21(6:0)** R2LED Current1 Setting (At RGBSETpin 120kΩ connection)

"0000000" : 0.0 mA	"0110010" : 10.0mA	"1100100" : 20.0mA
"0000001" : 0.2 mA	"0110011" : 10.2mA	"1100101" : 20.2mA
"0000010" : 0.4 mA	"0110100" : 10.4mA	"1100110" : 20.4mA
"0000011" : 0.6 mA	"0110101" : 10.6mA	"1100111" : 20.6mA
"0000100" : 0.8 mA	"0110110" : 10.8mA	"1101000" : 20.8mA
"0000101" : 1.0 mA	"0110111" : 11.0mA	"1101001" : 21.0mA
"0000110" : 1.2 mA	"0111000" : 11.2mA	"1101010" : 21.2mA
"0000111" : 1.4 mA	"0111001" : 11.4mA	"1101011" : 21.4mA
"0001000" : 1.6 mA	"0111010" : 11.6mA	"1101100" : 21.6mA
"0001001" : 1.8 mA	"0111011" : 11.8mA	"1101101" : 21.8mA
"0001010" : 2.0 mA	"0111100" : 12.0mA	"1101110" : 22.0mA
"0001011" : 2.2 mA	"0111101" : 12.2mA	"1101111" : 22.2mA
"0001100" : 2.4 mA	"0111110" : 12.4mA	"1110000" : 22.4mA
"0001101" : 2.6 mA	"0111111" : 12.6mA	"1110001" : 22.6mA
"0001110" : 2.8 mA	"1000000" : 12.8mA	"1110010" : 22.8mA
"0001111" : 3.0 mA	"1000001" : 13.0mA	"1110011" : 23.0mA
"0010000" : 3.2 mA	"1000010" : 13.2mA	"1110100" : 23.2mA
"0010001" : 3.4 mA	"1000011" : 13.4mA	"1110101" : 23.4mA
"0010010" : 3.6 mA	"1000100" : 13.6mA	"1110110" : 23.6mA
"0010011" : 3.8 mA	"1000101" : 13.8mA	"1110111" : 23.8mA
"0010100" : 4.0 mA	"1000110" : 14.0mA	"1111000" : 24.0mA
"0010101" : 4.2 mA	"1000111" : 14.2mA	"1111001" : 24.2mA
"0010110" : 4.4 mA	"1001000" : 14.4mA	"1111010" : 24.4mA
"0010111" : 4.6 mA	"1001001" : 14.6mA	"1111011" : 24.6mA
"0011000" : 4.8 mA	"1001010" : 14.8mA	"1111100" : 24.8mA
"0011001" : 5.0 mA	"1001011" : 15.0mA	"1111101" : 25.0mA
"0011010" : 5.2 mA	"1001100" : 15.2mA	"1111110" : 25.2mA
"0011011" : 5.4 mA	"1001101" : 15.4mA	"1111111" : 25.4mA
"0011100" : 5.6 mA	"1001110" : 15.6mA	
"0011101" : 5.8 mA	"1001111" : 15.8mA	
"0011110" : 6.0 mA	"1010000" : 16.0mA	
"0011111" : 6.2 mA	"1010001" : 16.2mA	
"0100000" : 6.4 mA	"1010010" : 16.4mA	
"0100001" : 6.6 mA	"1010011" : 16.6mA	
"0100010" : 6.8 mA	"1010100" : 16.8mA	
"0100011" : 7.0 mA	"1010101" : 17.0mA	
"0100100" : 7.2 mA	"1010110" : 17.2mA	
"0100101" : 7.4 mA	"1010111" : 17.4mA	
"0100110" : 7.6 mA	"1011000" : 17.6mA	
"0100111" : 7.8 mA	"1011001" : 17.8mA	
"0101000" : 8.0 mA	"1011010" : 18.0mA	
"0101001" : 8.2 mA	"1011011" : 18.2mA	
"0101010" : 8.4 mA	"1011100" : 18.4mA	
"0101011" : 8.6 mA	"1011101" : 18.6mA	
"0101100" : 8.8 mA	"1011110" : 18.8mA	
"0101101" : 9.0 mA	"1011111" : 19.0mA	
"0101110" : 9.2 mA	"1100000" : 19.2mA	
"0101111" : 9.4 mA	"1100001" : 19.4mA	
"0110000" : 9.6 mA	"1100010" : 19.6mA	
"0110001" : 9.8 mA	"1100011" : 19.8mA	

Refer to "3. Current settings 1 and 2 (I1, I2)" of "●RGB Waveform Setting" for detail

Address 32h < R2 current 2setup >

Address	R/W	Bit7	Bit6	Bit5	Bit4	Bit3	Bit2	Bit1	Bit0
32h	W	-	IR22(6)	IR22(5)	IR22(4)	IR22(3)	IR22(2)	IR22(1)	IR22(0)
Initial Value	00h	-	-	0	0	0	0	0	0

Bit7 : (Not used)

Bit [6:0] : **IR22(6:0)** R2LED Current2 Setting (At RGBSETpin 120kΩ connection)

"0000000" : 0.0 mA	"0110010" : 10.0mA	"1100100" : 20.0mA
"0000001" : 0.2 mA	"0110011" : 10.2mA	"1100101" : 20.2mA
"0000010" : 0.4 mA	"0110100" : 10.4mA	"1100110" : 20.4mA
"0000011" : 0.6 mA	"0110101" : 10.6mA	"1100111" : 20.6mA
"0000100" : 0.8 mA	"0110110" : 10.8mA	"1101000" : 20.8mA
"0000101" : 1.0 mA	"0110111" : 11.0mA	"1101001" : 21.0mA
"0000110" : 1.2 mA	"0111000" : 11.2mA	"1101010" : 21.2mA
"0000111" : 1.4 mA	"0111001" : 11.4mA	"1101011" : 21.4mA
"0001000" : 1.6 mA	"0111010" : 11.6mA	"1101100" : 21.6mA
"0001001" : 1.8 mA	"0111011" : 11.8mA	"1101101" : 21.8mA
"0001010" : 2.0 mA	"0111100" : 12.0mA	"1101110" : 22.0mA
"0001011" : 2.2 mA	"0111101" : 12.2mA	"1101111" : 22.2mA
"0001100" : 2.4 mA	"0111110" : 12.4mA	"1110000" : 22.4mA
"0001101" : 2.6 mA	"0111111" : 12.6mA	"1110001" : 22.6mA
"0001110" : 2.8 mA	"1000000" : 12.8mA	"1110010" : 22.8mA
"0001111" : 3.0 mA	"1000001" : 13.0mA	"1110011" : 23.0mA
"0010000" : 3.2 mA	"1000010" : 13.2mA	"1110100" : 23.2mA
"0010001" : 3.4 mA	"1000011" : 13.4mA	"1110101" : 23.4mA
"0010010" : 3.6 mA	"1000100" : 13.6mA	"1110110" : 23.6mA
"0010011" : 3.8 mA	"1000101" : 13.8mA	"1110111" : 23.8mA
"0010100" : 4.0 mA	"1000110" : 14.0mA	"1111000" : 24.0mA
"0010101" : 4.2 mA	"1000111" : 14.2mA	"1111001" : 24.2mA
"0010110" : 4.4 mA	"1001000" : 14.4mA	"1111010" : 24.4mA
"0010111" : 4.6 mA	"1001001" : 14.6mA	"1111011" : 24.6mA
"0011000" : 4.8 mA	"1001010" : 14.8mA	"1111100" : 24.8mA
"0011001" : 5.0 mA	"1001011" : 15.0mA	"1111101" : 25.0mA
"0011010" : 5.2 mA	"1001100" : 15.2mA	"1111110" : 25.2mA
"0011011" : 5.4 mA	"1001101" : 15.4mA	"1111111" : 25.4mA
"0011100" : 5.6 mA	"1001110" : 15.6mA	
"0011101" : 5.8 mA	"1001111" : 15.8mA	
"0011110" : 6.0 mA	"1010000" : 16.0mA	
"0011111" : 6.2 mA	"1010001" : 16.2mA	
"0100000" : 6.4 mA	"1010010" : 16.4mA	
"0100001" : 6.6 mA	"1010011" : 16.6mA	
"0100010" : 6.8 mA	"1010100" : 16.8mA	
"0100011" : 7.0 mA	"1010101" : 17.0mA	
"0100100" : 7.2 mA	"1010110" : 17.2mA	
"0100101" : 7.4 mA	"1010111" : 17.4mA	
"0100110" : 7.6 mA	"1011000" : 17.6mA	
"0100111" : 7.8 mA	"1011001" : 17.8mA	
"0101000" : 8.0 mA	"1011010" : 18.0mA	
"0101001" : 8.2 mA	"1011011" : 18.2mA	
"0101010" : 8.4 mA	"1011100" : 18.4mA	
"0101011" : 8.6 mA	"1011101" : 18.6mA	
"0101100" : 8.8 mA	"1011110" : 18.8mA	
"0101101" : 9.0 mA	"1011111" : 19.0mA	
"0101110" : 9.2 mA	"1100000" : 19.2mA	
"0101111" : 9.4 mA	"1100001" : 19.4mA	
"0110000" : 9.6 mA	"1100010" : 19.6mA	
"0110001" : 9.8 mA	"1100011" : 19.8mA	

Refer to "3. Current settings 1 and 2 (I1, I2)" of "●RGB Waveform Setting" for detail.

Address 33h < R2 Wave Pattern setup >

Address	R/W	Bit7	Bit6	Bit5	Bit4	Bit3	Bit2	Bit1	Bit0
33h	W	-	-	-	-	PR2(3)	PR2(2)	PR2(1)	PR2(0)
Initial Value	00h	-	-	0	0	0	0	0	0

Bit [7:4] : (Not used)

Bit [3:0] : **PR2(3:0)** R2LED Wave Pattern

"0000" : Pattern 1
 "0001" : Pattern 2
 "0010" : Pattern 3
 "0011" : Pattern 4
 "0100" : Pattern 5
 "0101" : Pattern 6
 "0110" : Pattern 7
 "0111" : Pattern 8
 "1000" : Pattern 9
 "1001" : Pattern 10
 "1010" : Pattern 11
 "1011" : Pattern 12
 "1100" : Pattern 13
 "1101" : Pattern 14
 "1110" : Pattern 15
 "1111" : Pattern 16

Refer to "2. Waveform pattern" of "●RGB Waveform Setting" for detail.

Address 34h < G2 current 1setup >

Address	R/W	Bit7	Bit6	Bit5	Bit4	Bit3	Bit2	Bit1	Bit0
34h	W	-	IG21(6)	IG21(5)	IG21(4)	IG21(3)	IG21(2)	IG21(1)	IG21(0)
Initial Value	00h	-	-	0	0	0	0	0	0

Bit7 : (Not used)

Bit [6:0] : **IG21(6:0)** G2LED Current1 Setting (At RGBSETpin 120kΩ connection)

"0000000" : 0.0 mA	"0110010" : 10.0mA	"1100100" : 20.0mA
"0000001" : 0.2 mA	"0110011" : 10.2mA	"1100101" : 20.2mA
"0000010" : 0.4 mA	"0110100" : 10.4mA	"1100110" : 20.4mA
"0000011" : 0.6 mA	"0110101" : 10.6mA	"1100111" : 20.6mA
"0000100" : 0.8 mA	"0110110" : 10.8mA	"1101000" : 20.8mA
"0000101" : 1.0 mA	"0110111" : 11.0mA	"1101001" : 21.0mA
"0000110" : 1.2 mA	"0111000" : 11.2mA	"1101010" : 21.2mA
"0000111" : 1.4 mA	"0111001" : 11.4mA	"1101011" : 21.4mA
"0001000" : 1.6 mA	"0111010" : 11.6mA	"1101100" : 21.6mA
"0001001" : 1.8 mA	"0111011" : 11.8mA	"1101101" : 21.8mA
"0001010" : 2.0 mA	"0111100" : 12.0mA	"1101110" : 22.0mA
"0001011" : 2.2 mA	"0111101" : 12.2mA	"1101111" : 22.2mA
"0001100" : 2.4 mA	"0111110" : 12.4mA	"1110000" : 22.4mA
"0001101" : 2.6 mA	"0111111" : 12.6mA	"1110001" : 22.6mA
"0001110" : 2.8 mA	"1000000" : 12.8mA	"1110010" : 22.8mA
"0001111" : 3.0 mA	"1000001" : 13.0mA	"1110011" : 23.0mA
"0010000" : 3.2 mA	"1000010" : 13.2mA	"1110100" : 23.2mA
"0010001" : 3.4 mA	"1000011" : 13.4mA	"1110101" : 23.4mA
"0010010" : 3.6 mA	"1000100" : 13.6mA	"1110110" : 23.6mA
"0010011" : 3.8 mA	"1000101" : 13.8mA	"1110111" : 23.8mA
"0010100" : 4.0 mA	"1000110" : 14.0mA	"1111000" : 24.0mA
"0010101" : 4.2 mA	"1000111" : 14.2mA	"1111001" : 24.2mA
"0010110" : 4.4 mA	"1001000" : 14.4mA	"1111010" : 24.4mA
"0010111" : 4.6 mA	"1001001" : 14.6mA	"1111011" : 24.6mA
"0011000" : 4.8 mA	"1001010" : 14.8mA	"1111100" : 24.8mA
"0011001" : 5.0 mA	"1001011" : 15.0mA	"1111101" : 25.0mA
"0011010" : 5.2 mA	"1001100" : 15.2mA	"1111110" : 25.2mA
"0011011" : 5.4 mA	"1001101" : 15.4mA	"1111111" : 25.4mA
"0011100" : 5.6 mA	"1001110" : 15.6mA	
"0011101" : 5.8 mA	"1001111" : 15.8mA	
"0011110" : 6.0 mA	"1010000" : 16.0mA	
"0011111" : 6.2 mA	"1010001" : 16.2mA	
"0100000" : 6.4 mA	"1010010" : 16.4mA	
"0100001" : 6.6 mA	"1010011" : 16.6mA	
"0100010" : 6.8 mA	"1010100" : 16.8mA	
"0100011" : 7.0 mA	"1010101" : 17.0mA	
"0100100" : 7.2 mA	"1010110" : 17.2mA	
"0100101" : 7.4 mA	"1010111" : 17.4mA	
"0100110" : 7.6 mA	"1011000" : 17.6mA	
"0100111" : 7.8 mA	"1011001" : 17.8mA	
"0101000" : 8.0 mA	"1011010" : 18.0mA	
"0101001" : 8.2 mA	"1011011" : 18.2mA	
"0101010" : 8.4 mA	"1011100" : 18.4mA	
"0101011" : 8.6 mA	"1011101" : 18.6mA	
"0101100" : 8.8 mA	"1011110" : 18.8mA	
"0101101" : 9.0 mA	"1011111" : 19.0mA	
"0101110" : 9.2 mA	"1100000" : 19.2mA	
"0101111" : 9.4 mA	"1100001" : 19.4mA	
"0110000" : 9.6 mA	"1100010" : 19.6mA	
"0110001" : 9.8 mA	"1100011" : 19.8mA	

Refer to "3. Current settings 1 and 2 (I1, I2)" of "●RGB Waveform Setting" for detail.

Address 35h < G2 current 2setup >

Add ress	R/W	Bit7	Bit6	Bit5	Bit4	Bit3	Bit2	Bit1	Bit0
35h	W	-	IG22(6)	IG22(5)	IG22(4)	IG22(3)	IG22(2)	IG22(1)	IG22(0)
Initial Value	00h	-	-	0	0	0	0	0	0

Bit7 : (Not used)

Bit [6:0] : **IG22(6:0)** G2LED Current2 Setting (At RGBSETpin 120kΩ connection)

"0000000" : 0.0 mA	"0110010" : 10.0mA	"1100100" : 20.0mA
"0000001" : 0.2 mA	"0110011" : 10.2mA	"1100101" : 20.2mA
"0000010" : 0.4 mA	"0110100" : 10.4mA	"1100110" : 20.4mA
"0000011" : 0.6 mA	"0110101" : 10.6mA	"1100111" : 20.6mA
"0000100" : 0.8 mA	"0110110" : 10.8mA	"1101000" : 20.8mA
"0000101" : 1.0 mA	"0110111" : 11.0mA	"1101001" : 21.0mA
"0000110" : 1.2 mA	"0111000" : 11.2mA	"1101010" : 21.2mA
"0000111" : 1.4 mA	"0111001" : 11.4mA	"1101011" : 21.4mA
"0001000" : 1.6 mA	"0111010" : 11.6mA	"1101100" : 21.6mA
"0001001" : 1.8 mA	"0111011" : 11.8mA	"1101101" : 21.8mA
"0001010" : 2.0 mA	"0111100" : 12.0mA	"1101110" : 22.0mA
"0001011" : 2.2 mA	"0111101" : 12.2mA	"1101111" : 22.2mA
"0001100" : 2.4 mA	"0111110" : 12.4mA	"1110000" : 22.4mA
"0001101" : 2.6 mA	"0111111" : 12.6mA	"1110001" : 22.6mA
"0001110" : 2.8 mA	"1000000" : 12.8mA	"1110010" : 22.8mA
"0001111" : 3.0 mA	"1000001" : 13.0mA	"1110011" : 23.0mA
"0010000" : 3.2 mA	"1000010" : 13.2mA	"1110100" : 23.2mA
"0010001" : 3.4 mA	"1000011" : 13.4mA	"1110101" : 23.4mA
"0010010" : 3.6 mA	"1000100" : 13.6mA	"1110110" : 23.6mA
"0010011" : 3.8 mA	"1000101" : 13.8mA	"1110111" : 23.8mA
"0010100" : 4.0 mA	"1000110" : 13.0mA	"1111000" : 24.0mA
"0010101" : 4.2 mA	"1000111" : 14.2mA	"1111001" : 24.2mA
"0010110" : 4.4 mA	"1001000" : 14.4mA	"1111010" : 24.4mA
"0010111" : 4.6 mA	"1001001" : 14.6mA	"1111011" : 24.6mA
"0011000" : 4.8 mA	"1001010" : 14.8mA	"1111100" : 24.8mA
"0011001" : 5.0 mA	"1001011" : 15.0mA	"1111101" : 25.0mA
"0011010" : 5.2 mA	"1001100" : 15.2mA	"1111110" : 25.2mA
"0011011" : 5.4 mA	"1001101" : 15.4mA	"1111111" : 25.4mA
"0011100" : 5.6 mA	"1001110" : 15.6mA	
"0011101" : 5.8 mA	"1001111" : 15.8mA	
"0011110" : 6.0 mA	"1010000" : 16.0mA	
"0011111" : 6.2 mA	"1010001" : 16.2mA	
"0100000" : 6.4 mA	"1010010" : 16.4mA	
"0100001" : 6.6 mA	"1010011" : 16.6mA	
"0100010" : 6.8 mA	"1010100" : 16.8mA	
"0100011" : 7.0 mA	"1010101" : 17.0mA	
"0100100" : 7.2 mA	"1010110" : 17.2mA	
"0100101" : 7.4 mA	"1010111" : 17.4mA	
"0100110" : 7.6 mA	"1011000" : 17.6mA	
"0100111" : 7.8 mA	"1011001" : 17.8mA	
"0101000" : 8.0 mA	"1011010" : 18.0mA	
"0101001" : 8.2 mA	"1011011" : 18.2mA	
"0101010" : 8.4 mA	"1011100" : 18.4mA	
"0101011" : 8.6 mA	"1011101" : 18.6mA	
"0101100" : 8.8 mA	"1011110" : 18.8mA	
"0101101" : 9.0 mA	"1011111" : 19.0mA	
"0101110" : 9.2 mA	"1100000" : 19.2mA	
"0101111" : 9.4 mA	"1100001" : 19.4mA	
"0110000" : 9.6 mA	"1100010" : 19.6mA	
"0110001" : 9.8 mA	"1100011" : 19.8mA	

Refer to "3. Current settings 1 and 2 (I1, I2)" of "●RGB Waveform Setting" for detail.

Address 36h < G2 Wave Pattern setup >

Address	R/W	Bit7	Bit6	Bit5	Bit4	Bit3	Bit2	Bit1	Bit0
36h	W	-	-	-	-	PG2(3)	PG2(2)	PG2(1)	PG2(0)
Initial Value	00h	-	-	0	0	0	0	0	0

Bit [7:4] : (Not used)

Bit [3:0] : **PG2(3:0)** G2LED Wave Pattern

"0000" : Pattern 1

"0001" : Pattern 2

"0010" : Pattern 3

"0011" : Pattern 4

"0100" : Pattern 5

"0101" : Pattern 6

"0110" : Pattern 7

"0111" : Pattern 8

"1000" : Pattern 9

"1001" : Pattern 10

"1010" : Pattern 11

"1011" : Pattern 12

"1100" : Pattern 13

"1101" : Pattern 14

"1110" : Pattern 15

"1111" : Pattern 16

refer to "2. Waveform pattern" of "●RGB Waveform Setting" for detail.

Address 37h < B2 current 1setup >

Address	R/W	Bit7	Bit6	Bit5	Bit4	Bit3	Bit2	Bit1	Bit0
37h	W	-	IB21(6)	IB21(5)	IB21(4)	IB21(3)	IB21(2)	IB21(1)	IB21(0)
Initial Value	00h	-	-	0	0	0	0	0	0

Bit7 : (Not used)

Bit [6:0] : **IB21(6:0)** B2LED Current1 Setting (At RGBISETpin 120kΩ connection)

"0000000" : 0.0 mA	"0110010" : 10.0mA	"1100100" : 20.0mA
"0000001" : 0.2 mA	"0110011" : 10.2mA	"1100101" : 20.2mA
"0000010" : 0.4 mA	"0110100" : 10.4mA	"1100110" : 20.4mA
"0000011" : 0.6 mA	"0110101" : 10.6mA	"1100111" : 20.6mA
"0000100" : 0.8 mA	"0110110" : 10.8mA	"1101000" : 20.8mA
"0000101" : 1.0 mA	"0110111" : 11.0mA	"1101001" : 21.0mA
"0000110" : 1.2 mA	"0111000" : 11.2mA	"1101010" : 21.2mA
"0000111" : 1.4 mA	"0111001" : 11.4mA	"1101011" : 21.4mA
"0001000" : 1.6 mA	"0111010" : 11.6mA	"1101100" : 21.6mA
"0001001" : 1.8 mA	"0111011" : 11.8mA	"1101101" : 21.8mA
"0001010" : 2.0 mA	"0111100" : 12.0mA	"1101110" : 22.0mA
"0001011" : 2.2 mA	"0111101" : 12.2mA	"1101111" : 22.2mA
"0001100" : 2.4 mA	"0111110" : 12.4mA	"1110000" : 22.4mA
"0001101" : 2.6 mA	"0111111" : 12.6mA	"1110001" : 22.6mA
"0001110" : 2.8 mA	"1000000" : 12.8mA	"1110010" : 22.8mA
"0001111" : 3.0 mA	"1000001" : 13.0mA	"1110011" : 23.0mA
"0010000" : 3.2 mA	"1000010" : 13.2mA	"1110100" : 23.2mA
"0010001" : 3.4 mA	"1000011" : 13.4mA	"1110101" : 23.4mA
"0010010" : 3.6 mA	"1000100" : 13.6mA	"1110110" : 23.6mA
"0010011" : 3.8 mA	"1000101" : 13.8mA	"1110111" : 23.8mA
"0010100" : 4.0 mA	"1000110" : 14.0mA	"1111000" : 24.0mA
"0010101" : 4.2 mA	"1000111" : 14.2mA	"1111001" : 24.2mA
"0010110" : 4.4 mA	"1001000" : 14.4mA	"1111010" : 24.4mA
"0010111" : 4.6 mA	"1001001" : 14.6mA	"1111011" : 24.6mA
"0011000" : 4.8 mA	"1001010" : 14.8mA	"1111100" : 24.8mA
"0011001" : 5.0 mA	"1001011" : 15.0mA	"1111101" : 25.0mA
"0011010" : 5.2 mA	"1001100" : 15.2mA	"1111110" : 25.2mA
"0011011" : 5.4 mA	"1001101" : 15.4mA	"1111111" : 25.4mA
"0011100" : 5.6 mA	"1001110" : 15.6mA	
"0011101" : 5.8 mA	"1001111" : 15.8mA	
"0011110" : 6.0 mA	"1010000" : 16.0mA	
"0011111" : 6.2 mA	"1010001" : 16.2mA	
"0100000" : 6.4 mA	"1010010" : 16.4mA	
"0100001" : 6.6 mA	"1010011" : 16.6mA	
"0100010" : 6.8 mA	"1010100" : 16.8mA	
"0100011" : 7.0 mA	"1010101" : 17.0mA	
"0100100" : 7.2 mA	"1010110" : 17.2mA	
"0100101" : 7.4 mA	"1010111" : 17.4mA	
"0100110" : 7.6 mA	"1011000" : 17.6mA	
"0100111" : 7.8 mA	"1011001" : 17.8mA	
"0101000" : 8.0 mA	"1011010" : 18.0mA	
"0101001" : 8.2 mA	"1011011" : 18.2mA	
"0101010" : 8.4 mA	"1011100" : 18.4mA	
"0101011" : 8.6 mA	"1011101" : 18.6mA	
"0101100" : 8.8 mA	"1011110" : 18.8mA	
"0101101" : 9.0 mA	"1011111" : 19.0mA	
"0101110" : 9.2 mA	"1100000" : 19.2mA	
"0101111" : 9.4 mA	"1100001" : 19.4mA	
"0110000" : 9.6 mA	"1100010" : 19.6mA	
"0110001" : 9.8 mA	"1100011" : 19.8mA	

Refer to "3. Current settings 1 and 2 (I1, I2)" of "●RGB Waveform Setting" for detail.

Address 38h < B2 current 2setup >

Address	R/W	Bit7	Bit6	Bit5	Bit4	Bit3	Bit2	Bit1	Bit0
38h	W	-	IB22(6)	IB22 (5)	IB22(4)	IB22(3)	IB22(2)	IB22(1)	IB22(0)
Initial Value	00h	-	-	0	0	0	0	0	0

Bit7 : (Not used)

Bit [6:0] : **IB22(6:0)** B2LED Current2 Setting (At RGBISETpin 120kΩ connection)

"0000000" : 0.0 mA	"0110010" : 10.0mA	"1100100" : 20.0mA
"0000001" : 0.2 mA	"0110011" : 10.2mA	"1100101" : 20.2mA
"0000010" : 0.4 mA	"0110100" : 10.4mA	"1100110" : 20.4mA
"0000011" : 0.6 mA	"0110101" : 10.6mA	"1100111" : 20.6mA
"0000100" : 0.8 mA	"0110110" : 10.8mA	"1101000" : 20.8mA
"0000101" : 1.0 mA	"0110111" : 11.0mA	"1101001" : 21.0mA
"0000110" : 1.2 mA	"0111000" : 11.2mA	"1101010" : 21.2mA
"0000111" : 1.4 mA	"0111001" : 11.4mA	"1101011" : 21.4mA
"0001000" : 1.6 mA	"0111010" : 11.6mA	"1101100" : 21.6mA
"0001001" : 1.8 mA	"0111011" : 11.8mA	"1101101" : 21.8mA
"0001010" : 2.0 mA	"0111100" : 12.0mA	"1101110" : 22.0mA
"0001011" : 2.2 mA	"0111101" : 12.2mA	"1101111" : 22.2mA
"0001100" : 2.4 mA	"0111110" : 12.4mA	"1110000" : 22.4mA
"0001101" : 2.6 mA	"0111111" : 12.6mA	"1110001" : 22.6mA
"0001110" : 2.8 mA	"1000000" : 12.8mA	"1110010" : 22.8mA
"0001111" : 3.0 mA	"1000001" : 13.0mA	"1110011" : 23.0mA
"0010000" : 3.2 mA	"1000010" : 13.2mA	"1110100" : 23.2mA
"0010001" : 3.4 mA	"1000011" : 13.4mA	"1110101" : 23.4mA
"0010010" : 3.6 mA	"1000100" : 13.6mA	"1110110" : 23.6mA
"0010011" : 3.8 mA	"1000101" : 13.8mA	"1110111" : 23.8mA
"0010100" : 4.0 mA	"1000110" : 14.0mA	"1111000" : 24.0mA
"0010101" : 4.2 mA	"1000111" : 14.2mA	"1111001" : 24.2mA
"0010110" : 4.4 mA	"1001000" : 14.4mA	"1111010" : 24.4mA
"0010111" : 4.6 mA	"1001001" : 14.6mA	"1111011" : 24.6mA
"0011000" : 4.8 mA	"1001010" : 14.8mA	"1111100" : 24.8mA
"0011001" : 5.0 mA	"1001011" : 15.0mA	"1111101" : 25.0mA
"0011010" : 5.2 mA	"1001100" : 15.2mA	"1111110" : 25.2mA
"0011011" : 5.4 mA	"1001101" : 15.4mA	"1111111" : 25.4mA
"0011100" : 5.6 mA	"1001110" : 15.6mA	
"0011101" : 5.8 mA	"1001111" : 15.8mA	
"0011110" : 6.0 mA	"1010000" : 16.0mA	
"0011111" : 6.2 mA	"1010001" : 16.2mA	
"0100000" : 6.4 mA	"1010010" : 16.4mA	
"0100001" : 6.6 mA	"1010011" : 16.6mA	
"0100010" : 6.8 mA	"1010100" : 16.8mA	
"0100011" : 7.0 mA	"1010101" : 17.0mA	
"0100100" : 7.2 mA	"1010110" : 17.2mA	
"0100101" : 7.4 mA	"1010111" : 17.4mA	
"0100110" : 7.6 mA	"1011000" : 17.6mA	
"0100111" : 7.8 mA	"1011001" : 17.8mA	
"0101000" : 8.0 mA	"1011010" : 18.0mA	
"0101001" : 8.2 mA	"1011011" : 18.2mA	
"0101010" : 8.4 mA	"1011100" : 18.4mA	
"0101011" : 8.6 mA	"1011101" : 18.6mA	
"0101100" : 8.8 mA	"1011110" : 18.8mA	
"0101101" : 9.0 mA	"1011111" : 19.0mA	
"0101110" : 9.2 mA	"1100000" : 19.2mA	
"0101111" : 9.4 mA	"1100001" : 19.4mA	
"0110000" : 9.6 mA	"1100010" : 19.6mA	
"0110001" : 9.8 mA	"1100011" : 19.8mA	

Refer to "3. Current settings 1 and 2 (I1, I2)" of "●RGB Waveform Setting" for detail.

Address 39h < B2 Wave Pattern setup >

Address	R/W	Bit7	Bit6	Bit5	Bit4	Bit3	Bit2	Bit1	Bit0
39h	W	-	-	-	-	PB(3)	PB(2)	PB(1)	PB(0)
Initial Value	00h	-	-	0	0	0	0	0	0

Bit [7:4] : (Not used)

Bit [3:0] : **PB(3:0)** B2LED Wave Pattern

"0000" : Pattern 1
 "0001" : Pattern 2
 "0010" : Pattern 3
 "0011" : Pattern 4
 "0100" : Pattern 5
 "0101" : Pattern 6
 "0110" : Pattern 7
 "0111" : Pattern 8
 "1000" : Pattern 9
 "1001" : Pattern 10
 "1010" : Pattern 11
 "1011" : Pattern 12
 "1100" : Pattern 13
 "1101" : Pattern 14
 "1110" : Pattern 15
 "1111" : Pattern 16

fer to "2. Waveform pattern" of "•RGB Waveform Setting" for detail.

●Description of white LED Driver Operations

- Comprises four lights (WLEDs1-4) for the main driver and three lights (WLEDs5-7) for general-purpose drivers.
- Permits the main driver to select either a fixed current mode based on a register or an auto light control mode by the auto light control module.
- Enables a general-purpose driver to designate an independent control mode based on a register and its attribution to the main group in units of terminals. This function makes it possible to assign the drivers easily depending on set designs such as main 4 LEDs/sub 2 LEDs/indicator 1ch and main 6 LEDs/sub 1 LED.
- Implements control as shown below when main group setting is designated via the W*MD bit.

Current setting:	Operates in conjunction with IMLED(6:0) (IW*(6:0) is discarded.)
ON/OFF control:	Operates in conjunction with MLEDEN. (W*EN is discarded.)
- Enables the main group to control PWM via the external terminal so that brightness control can be accomplished from the outside.

PWM control:	Inputs PWM via the external terminal "WPWMIN."
External synchronization:	Corrects a current value set by IOFS (5:0) in synchronization with the external terminal "OSYNC."
- Determines the LED current via a built-in resistance.
Permits the main group to perform slope processing so that the leading/trailing edge time can be set individually. The settings made in the registers THL (3:0) and TLH (3:0) are effective regardless of their light control mode (ON/OFF). To enable instant activation, the minimum value must be set for time.

●RGB LED Driver Operation Description

- Two drivers "RGB1 (R1LED, G1LED, B1LED)" and "RGB2 (R2LED, G2LED, B2LED)" are mounted.
- A slope function is incorporated to control drivers independently.
- Refer to ● RGB Waveform Setting for more information about output waveform setting.
- RGB2 can be used for GPO (Open drain output) It can be set up in every terminal with the register R2GPO, G2GPO and B2GPO.
- The LED current can be set via a resistance value (RISET) to be connected to the RGBISET terminal.
The maximum current value can be derived from the following expression:

$$I_{LEDmax} [A] = 3.048 / RISET [k\Omega] \text{ (Typ)}$$
 However, this setting must be made so that the maximum current value can be less than or equal to 30.48mA. In addition, the RGBISET terminal has an overcurrent protection circuit to prevent the excessive LED current from flowing for low impedance to the ground.
- Connection of each LED of RGB can be set up in VBAT or VOUT by the register RGB1PW (1:0) and RGB2PW (1:0). When Vf is low, it is connected to VBAT, and it is possible that efficiency is raised. When a VBAT connection is chosen, a return route to the DC/DC circuit is interrupted, and it works as a simple constant current driver. In this case, set it up to be less low than the saturation voltage (0.2V) of the fixed electric current circuit.

LED electric current When DC/DC isn't used.

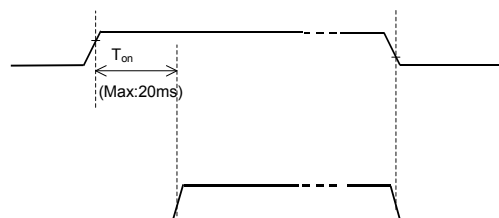

● General-purpose I/O Ports (GPIO1-GPIO4)

- Capable of selecting GPI and GPO independently according to the register setting.
- Capable of selecting a complementary or open drain output method so long as GPO is selected.
- Uses a VGPIO applied voltage as a logic level (during CMOS output setting and input setting).
When open drain output is selected, a pull-up resistance may be connected to a desirable location (VPUP) but the condition of $VGPIO \geq VPUP$ must be satisfied.
- Capable of outputting an interrupt signal via the INTB terminal (NMOS open drain) depending on an input logic change in each terminal and reading an input logic and an interrupt factor via I²C so long as GPI is selected.
Reflecting interrupts can be selected individually.

When input mask is set:

An input logic is sampled at the leading edge of a clock (having a frequency obtained by dividing 32KIN by 256).
When a sampling value differs from the contents of the existing output register consecutively three times, it is reflected on the output register (input logic and interrupt factor).

No input logic change is reflected on the INTB output.

When input mask is reset:

An input logic is sampled at the leading edge of a clock (having a frequency obtained by dividing 32KIN by 256).
When a sampling value differs from the contents of the existing output register consecutively three times, it is reflected on the output register (input logic and interrupt factor).

In addition, an interrupt pulse (one cycle of 32KIN with negative logic) is output simultaneously via INTB. The interrupt factor can be cleared by setting GPCLR (Address=23h, Bit=7) to H.

- Provide an idle GPIO terminal with a resistance of about 100kΩ for pull-down. (When GPIO1 to GPIO4 and KBLT are not used at all, short-circuiting of VGPIO and GND eliminates the need for using this pull-down resistance.)
- Each terminal of the GPIO block is initially set as follows:

GPIOs1-4: I/O mode

When using the output mode: The breakthrough current flows on an input buffer circuit until the output mode is set. When there is a problem, be sure to connect a pull-down resistance.
Once the output mode is set, the input buffer circuit must be set to OFF so that the breakthrough current cannot flow.

When using the input mode: The breakthrough current flows on an input buffer circuit unless an input voltage is fixed. When there is a problem, be sure to connect a pull-down resistance to fix the input voltage.

KBLT: L (A pull-down resistance is incorporated to prevent unstable output at voltage supply.)

INTB: Employs an external pull-down to set "H" for open drain output.

- Apply voltage to VGPIO as follows to prevent a malfunction which causes an unexpected operation on a GPIO circuit at activation time. VIO and VGPIO may be short-circuited. Even when only GPIO is used, voltage should apply to VIO too. To avoid erroneous output to the INTB terminal at activation time, don't reset the input mask of GPIO* prior to an elapse of 30ms after 32KN input. Because internal IO is activated at clock input, current dissipation arises even in the standby state. When there is a problem, stop 32KIN input.
- Input a clock of 50kHz or below to 32KIN.

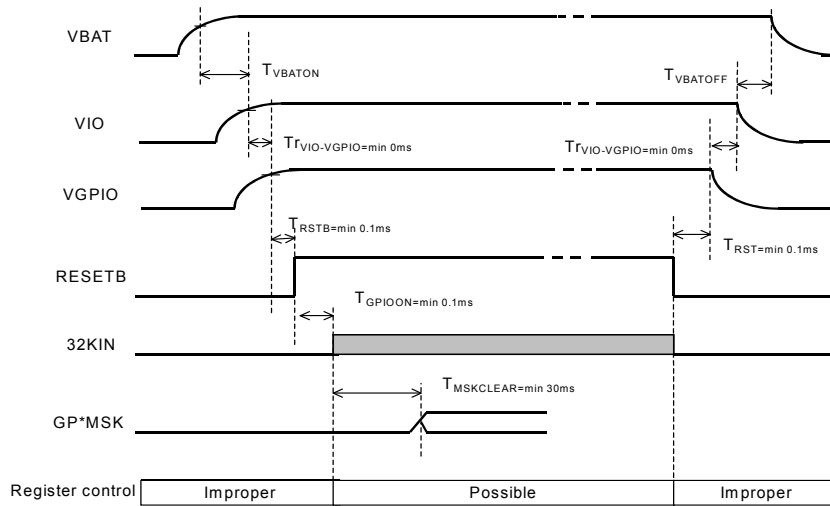

It is an example of a wave at the time of use as GPI.

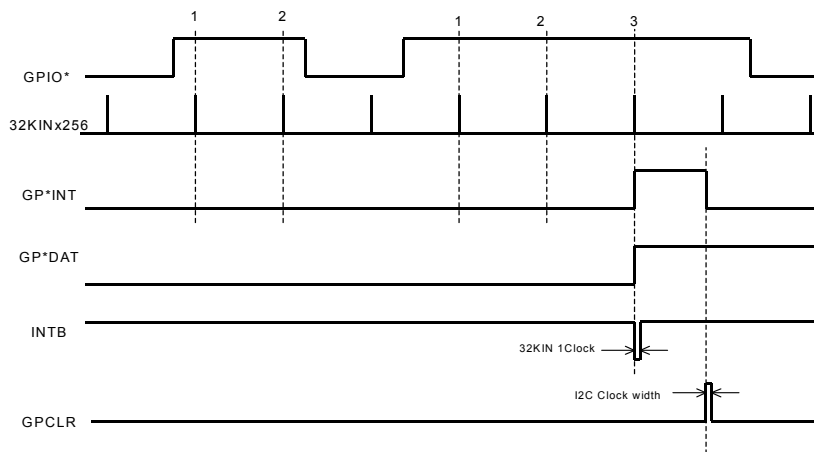

●Key Backlight Controller

- Capable of turning ON or OFF the key backlight according to the register setting or via the automatic light control module.
- Capable of adjusting illumination (ON time) according to the Duty setting via the built-in PWM (PWM frequency: 488Hz) and fade-in/fade-out via the slope function which steps PWM Duty at time intervals set in the KBSLP register.
- Determines a key backlight PWM frequency based on an internal clock rate of 1MHz. This value is identical to that at Typ (1MHz).
- Enables the selection of complementary or open drain for output and allows diversion to GPO.
- Uses a VGPIO applied voltage as a logic level (during CMOS output setting and input setting). When open drain output is selected, a pull-up resistance may be a desirable location (VPUP) but the condition of $VGPIO \geq VPUP$ must be satisfied.
- Mandatory to supply voltage to VGPIO for key backlight controller operations.

For a key backlight controller operating in conjunction with an auto luminous control (ALC) module

The register "KBFIX" must be set to 0 to enter the auto luminous control mode.

The ON/OFF condition to illumination intensity is set in the registers CTH (3:0) and CHYS (1:0).

The ON/OFF patterns of the key backlight are set in the registers MDTY (3:0) and KBSLP (1:0).

(For details of auto luminous control module setting, refer to ●Description of Auto Luminous Control Module Operations.)

For a key backlight controller capable of ON/OFF control according to register settings

The register "KBFIX" must be set to 1 to enter the register setting mode.

The slope time is set in the register "KBSLP (1:0)."

When the key backlight is turned ON, data equivalent to illumination intensity must be set in MDTY (3:0). When it is turned OFF, "0h" must be set instead.

For a key backlight controller to be used as GPO

The register "KBFIX" must be set to 1 to enter the register setting mode.

The register "KBSLP (1:0)" is set to 00 (without slope).

When "H" level output takes place as a GPO, the register "MDTY (3:0)" must be set to Fh. In contrast, when "L" level output takes place, the MDTY (3:0) must be set to 0h instead.

●RGB Waveform Setting

Various kinds of RGB control can be implemented by designating waveform cycles, waveform patterns, current settings 1, 2 and rising/falling slope times.

To activate a RGB waveform, a continuous operation via RGB*EN or a single-shot operation via RGB*OS can be selected. In addition, when control via the external terminal RGB*CNT is enabled via RGB*MEL, the corresponding LED can be lit in synchronization with the external signal.

1. Waveform cycle

- Single cycle time is set for a waveform pattern.
- This setting can be made independently for RGB1 and RGB2.

2. Waveform pattern

- A pattern in a waveform cycle is set.
- Sixteen types of waveform patterns can be set in units of waveform patterns.
- For concrete waveform patterns, refer to the timing diagram shown on the next page.

3. Current settings 1 and 2 (I1, I2)

- Two currents in a waveform pattern are set.
- When the maximum current value is 25.4mA, it is possible to set the current ranging from 0 to 25.4mA with an increment of 0.2mA (128 steps).
- The polarity of a waveform is determined by the greater-than/ less-than relationship in the current setting.
- This setting can be made in units of terminals.

4. Rising/falling slope time

- A current change time during switching between current settings 1 and 2 is set. A time per step (0.2mA) is calculated based on a difference between the currents selected in current settings 1, 2 and a setting slope time.

For this reason, a time per step (0.2mA) is short when a difference between setting currents I1 and I2 is large. In contrast, it is long when a difference between setting currents I1 and I2 is small.

- Regardless of current settings 1 and 2, a rising slope time applies at current increase and a falling slope time applies at current decrease. For concrete waveform images, refer to the timing diagram shown on the next page.

5. External terminal synchronization control

When control via the external terminal RGB*CNT is enabled via RGB*MEL, lighting is enabled if the input external signal goes "H." In contrast, it is disabled if the external input signal goes "L." In this way, synchronization with the external signal is enabled so that LED can be blinked in conjunction with a ringing tone (a melody signaling a ringtone).

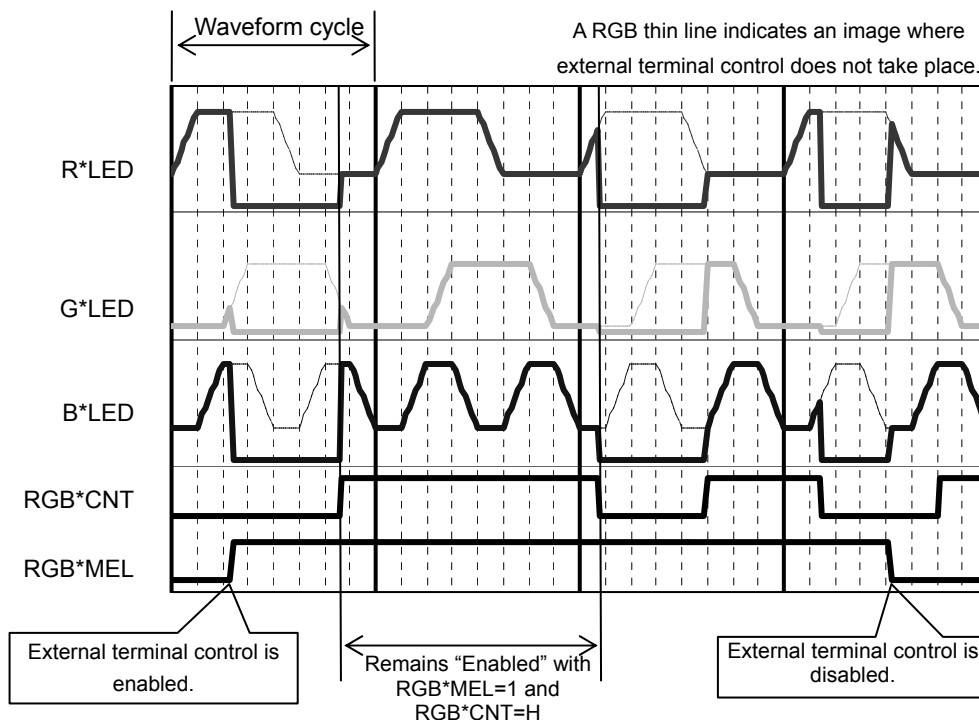

Register data		Wave cycle							
Wave pattern 1	(00h)	I1				I2			
Wave pattern 2	(01h)	I1				I2			
Wave pattern 3	(02h)		I1				I2		
Wave pattern 4	(03h)			I1				I2	
Wave pattern 5	(04h)				I1				I2
Wave pattern 6	(05h)					I1			I2
Wave pattern 7	(06h)						I1		I2
Wave pattern 8	(07h)							I1	
Wave pattern 9	(08h)	I1		I2				I1	
Wave pattern 10	(09h)		I1			I2			I1
Wave pattern 11	(0Ah)	I1		I2		I1		I2	I1
Wave pattern 12	(0Bh)	I1		I2		I1		I2	
Wave pattern 13	(0Ch)	I1			I2				I1
Wave pattern 14	(0Dh)	I1				I2			I1
Wave pattern 15	(0Eh)		I1				I2		I1
Wave pattern 16	(0Fh)	I1	I2	I1	I2	I1	I2	I1	I2

(ex) The image of current change of Wave pattern 11

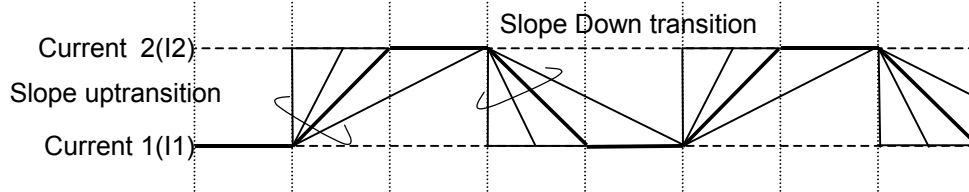

RGB wave setting timing diagram

6. Clock external output

The clock (31.25kHz (TYP)) of this LSI is output by making the setup of the register GPO1OSC "1" from the GPIO1 terminal. (Internal OSC is turned on separately, and you must make GPIO1 a setup of output.)

As extension of illuminations, a clock can be supplied to other RGB LED drivers, and it can be made to synchronize with this LSI. It is applicable to a clock supply means in case there is no clock for GPIO (32KIN).

7. RGB waveform setting examples

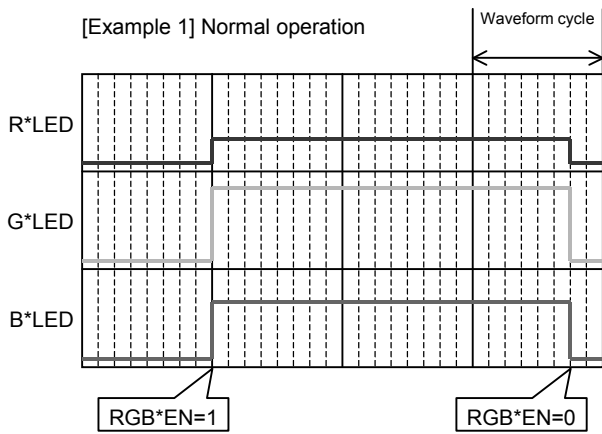

Selecting a waveform pattern 8 causes a continuous normal operation to take place through the setting current 1.

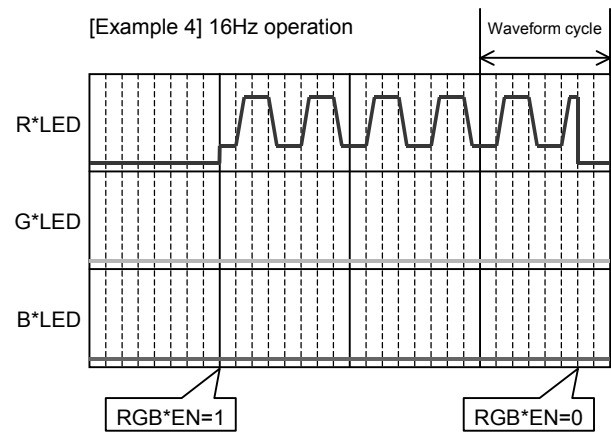

Combining the settings of a waveform pattern 11 and a waveform cycle 131ms causes blinking at a rate of 15.3Hz (approx. 16Hz).

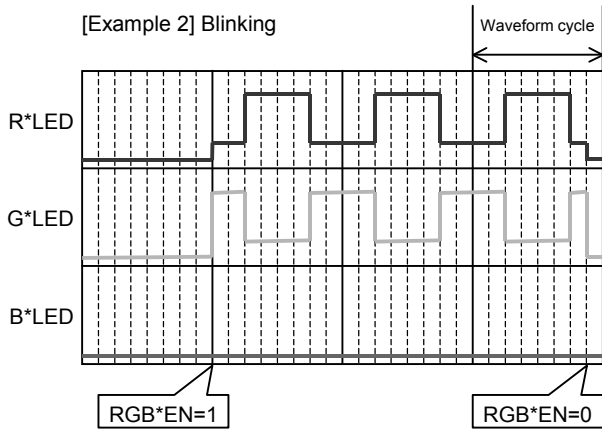

Setting a rising/falling slope time to "0" causes blinking to take place. Phase switching takes place via the setting currents of R and G.

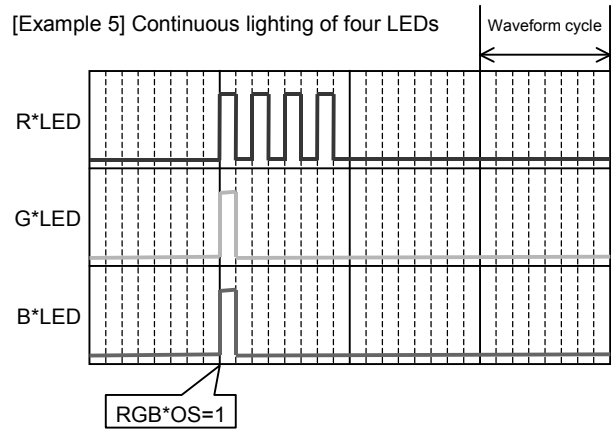

This example shows that lighting occurs continuously in the order of white, red, red and red.

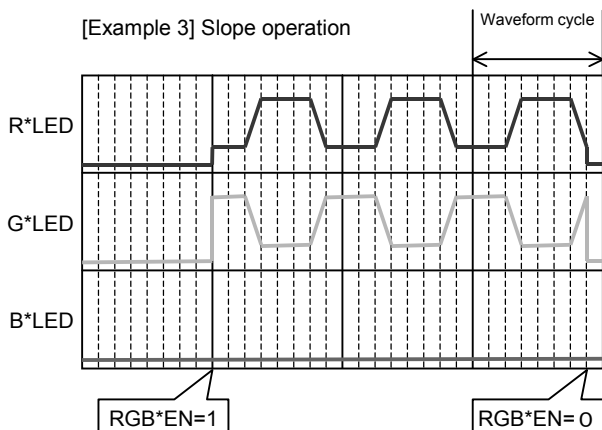

When a rising/falling slope time is longer than the setting made in example 2, a continuous color change is made by slope operation.

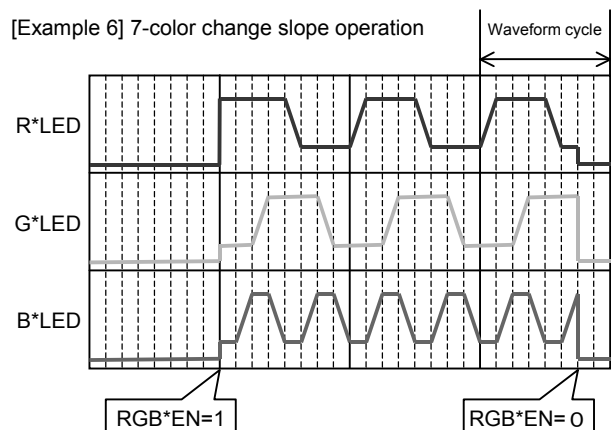

R, G and B waveform patterns are set in a way that any of R, G and B changes constantly.

8. RGB slope waveforms

- xample of waveform at activation

Current setting: $I1 < I2$

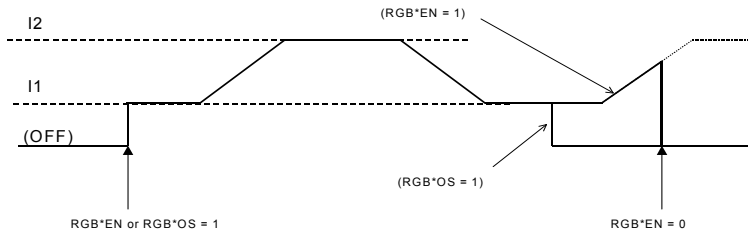

Current setting: $I1 > I2$

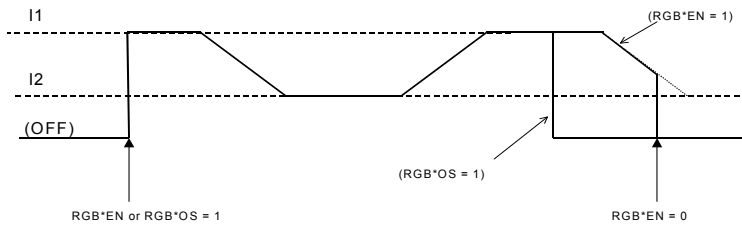

- urrent difference in each channel (example)

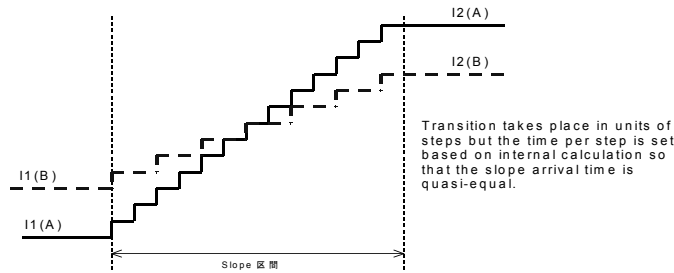

9. Setting change in slope duration

A slope operation is performed by an internal sequencer.

When an attempt is made to change the setting in a slope duration, the active slope operation is reset and a newly set slope operation is restarted.

In this case, however, LED lighting stops for a maximum of 16.4ms (OSC frequency=typ) for synchronization with the internal clock until the operation is restarted.

●The explanation of Auto Lighting Control

Dimming of LCD backlight and ON/OFF control of key backlight, are possible in the basis of the data detected by external ambient light a sensor.

- ince it has the bias adjustment function for sensors, ADC with an average filter, a gain offset adjustment function, and a LOG conversion function, an Ambient light can be broadly chosen from Photo Diode, Photo Transistor, Photo IC (a linear output / LOG output), etc.
- mbient light is changed into brightness data by digital processing. The external output of data is possible at I²C.
- onversion on LED current can choose a built-in initial table and a built-in user setting table.
- n LED driver is with a current value change slope function, and Auto Luminous control without sense of incongruity is possible for it.
- N/ off of the key back light can be controlled automatically by the brightness.

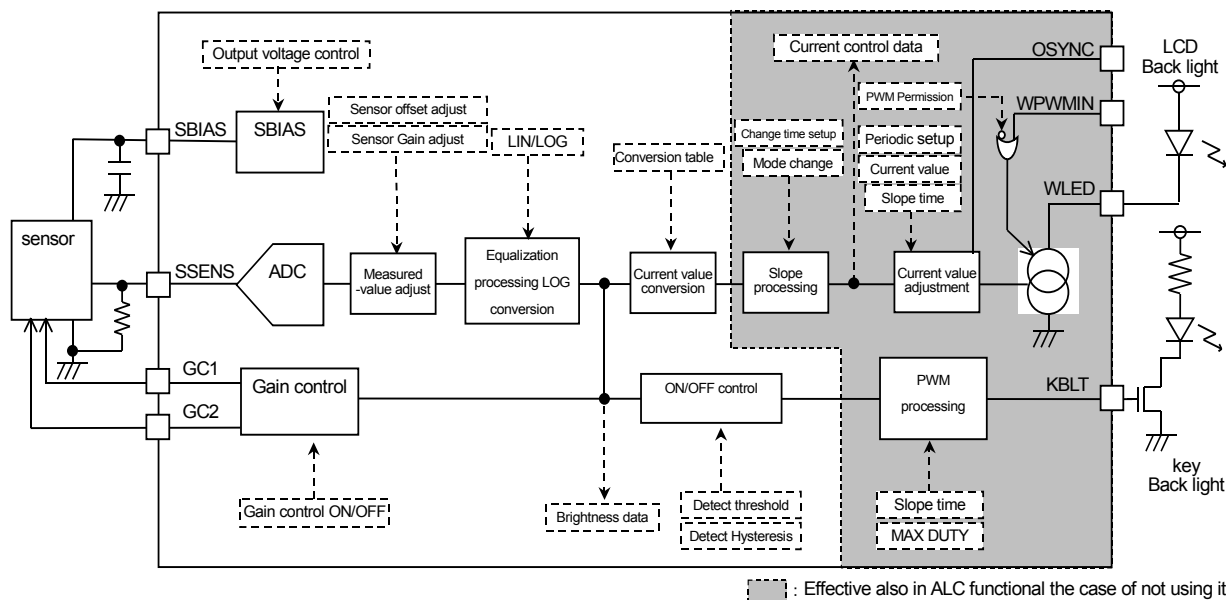

1. Auto Lighting Control ON/OFF

- It is independent of a back light / key back light section, and effective / non-effect can be set up and use only by reading of illuminance information is possible.
Bit : ALCEN

2. Sensor I/F

- It is possible to supply bias voltage to a sensor using SBIAS. Output voltage (VoS) can be adjusted by register setup.
Bit : VSB
- The external resistance for I/V conversion is adjusted according to the property of a sensor.

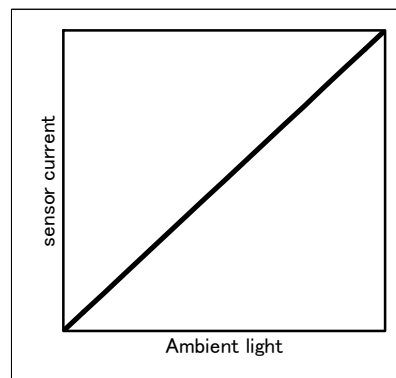

3. I/V conversion

Gain switching function is built in to extend the dynamic range. Effective / non-effect of automatic gain control are register setup. GC1 and the output logic of GC2 can be set up by the manual at the time of automatic gain control invalid.

Bit : GAIN (1:0)

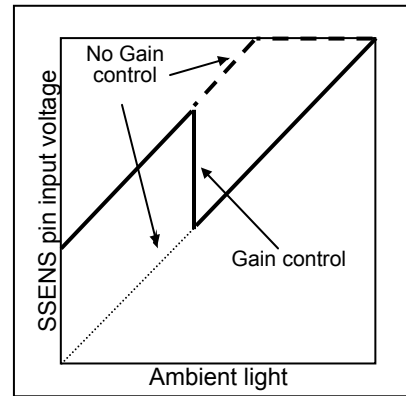

	ex1(BH1600FVC and connection)			ex3			ex3	
Application circuit								
Operation mode	Automatic	Manual		Automatic	Manual		Fixation	
GAIN(1:0)	00	01	10	00	01	00	01	
GC1 output	H L	H	L	H L	H	L	L	
GC2 output	L H	L	H	L H	L	H	L	
Sensor Application Gain state	Automatic	High	Low	Automatic	High	Low	-	

Auto Luminous control operates as Low Gain as High Gain at the time of "10" when GAIN (1:0) is "01."

(*1) Please set the relative ratio of resistance. In this case, be careful of the difference in brightness conversion in High Gain mode and Low Gain mode.

4. AD conversion

- Detection of Ambient light information is periodically performed for low-power realization. Bit : ADCYC(1:0)
- The current which turns off SBIAS and ADC and is generated by the sensor is controlled except the time of Ambient light measurement.
- SBIAS output equips with intermittent operation mode and always ON-mode. Pull-down [SBIAS and a SSENS terminal] inside at the time of OFF. Bit : SBIASON

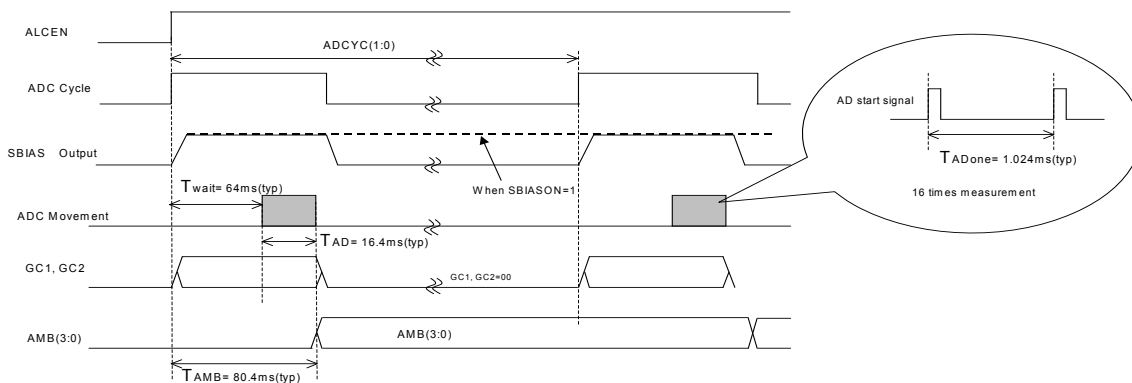

5. ADC data gain offset adjust

- Gain adjust and offset adjust to ADC output data are possible.
- adjust of gain and offset is a register setup.
 Bit : SGAIN (3:0)
 Bit : SOFS (3:0)

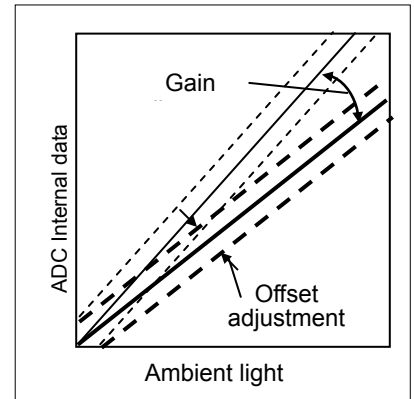

6. Average filter

- Average filter for cancel a noise (16 times Fixation)

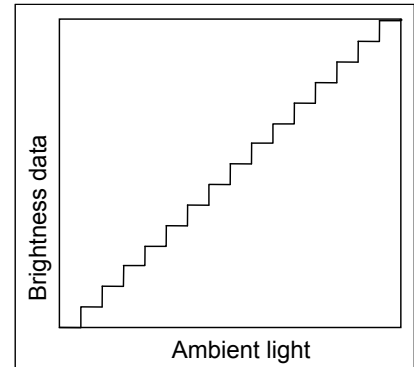

7. Brightness data conversion

- From Ambient light data, the rank judging of 16 steps suitable for brightness is carried out.
- Selection of the existence of LOG conversion with the type of Ambient light sensor is possible.

Linear type Sensor : LOG Conversion

LOG type Sensor : Data through

Bit : STYPE

- Brightness data can be read through I²C.

Brightness	SSENS voltage			
	LOG Those with conversion			With no LOG conversion
	GAIN no control (GAIN=11 STYPE=0)	GAIN control (exclude GAIN=11)		GAIN no control (GAIN=11 STYPE=1)
		Low mode	High mode	
0	VoS×0 / 256	-	VoS×0 / 256	VoS×0 / 256 VoS×17 / 256
1	VoS×1 / 256	-	VoS×1 / 256	VoS×18 / 256 VoS×26 / 256
2	VoS×2 / 256	-	VoS×2 / 256	VoS×27 / 256 VoS×36 / 256
3	VoS×3 / 256 VoS×4 / 256	-	VoS×3 / 256 VoS×4 / 256	VoS×37 / 256 VoS×47 / 256
4	VoS×5 / 256 VoS×6 / 256	-	VoS×5 / 256 VoS×7 / 256	VoS×48 / 256 VoS×59 / 256
5	VoS×7 / 256 VoS×9 / 256	VoS×0 / 256	VoS×8 / 256 VoS×12 / 256	VoS×60 / 256 VoS×71 / 256
6	VoS×10 / 256 VoS×13 / 256	VoS×1 / 256	VoS×13 / 256 VoS×21 / 256	VoS×72 / 256 VoS×83 / 256
7	VoS×14 / 256 VoS×19 / 256	VoS×2 / 256 VoS×3 / 256	VoS×22 / 256 VoS×37 / 256	VoS×84 / 256 VoS×95 / 256
8	VoS×20 / 256 VoS×27 / 256	VoS×4 / 256 VoS×6 / 256	VoS×38 / 256 VoS×65 / 256	VoS×96 / 256 VoS×107 / 256
9	VoS×28 / 256 VoS×38 / 256	VoS×7 / 256 VoS×11 / 256	VoS×66 / 256 VoS×113 / 256	VoS×108 / 256 VoS×119 / 256
A	VoS×39 / 256 VoS×53 / 256	VoS×12 / 256 VoS×20 / 256	VoS×114 / 256 VoS×199 / 256	VoS×120 / 256 VoS×131 / 256
B	VoS×54 / 256 VoS×74 / 256	VoS×21 / 256 VoS×36 / 256	VoS×200 / 256 VoS×255 / 256	VoS×132 / 256 VoS×143 / 256
C	VoS×75 / 256 VoS×104 / 256	VoS×37 / 256 VoS×64 / 256	-	VoS×144 / 256 VoS×155 / 256
D	VoS×105 / 256 VoS×144 / 256	VoS×65 / 256 VoS×114 / 256	-	VoS×156 / 256 VoS×168 / 256
E	VoS×145 / 256 VoS×199 / 256	VoS×115 / 256 VoS×199 / 256	-	VoS×169 / 256 VoS×181 / 256
F	VoS×200 / 256 VoS×255 / 256	VoS×200 / 256 VoS×255 / 256	-	VoS×182 / 256 VoS×255 / 256

Low mode / High mode changes with a color coating value (brightness) at the time of automatic control.

8. LED current conversion

- The current of the LED driver to each Brightness is set up.
 - Although a table setup (initial value) is prepared beforehand, it can change into a user setup by overwriting.
- Bit : IU*(6:0) (Back light)

Table setup (Initial value)

Brightness	setup	Current value	Brightness	setup	Current value
0	11h	3.6mA	8	48h	14.6mA
1	13h	4.0mA	9	56h	17.4mA
2	15h	4.4mA	A	5Fh	19.2mA
3	18h	5.0mA	B	63h	20.0mA
4	1Eh	6.2mA	C	63h	20.0mA
5	25h	7.6mA	D	63h	20.0mA
6	2Fh	9.6mA	E	63h	20.0mA
7	3Bh	12.0mA	F	63h	20.0mA

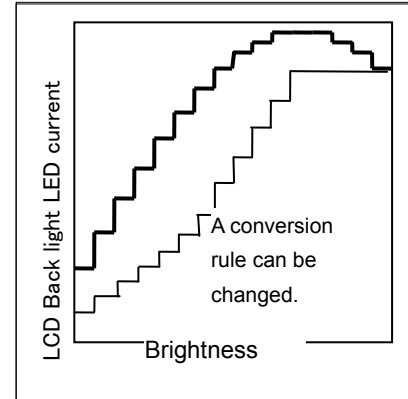

9. Slope process

- Slope process is given to LED current to dim naturally.
 - The slope function is carried also in the driver for keys.
 - LED current changes in the 256Step gradation in slopeing.
 - UP(dark→bright), Down(bright→dark) LED current transition speed are set individually.
- Bit : THL(3:0), TLH(3:0)
- Back light current changes as follows at the time of a slope. TLH (THL) is a time setup of the current steps 2/256.

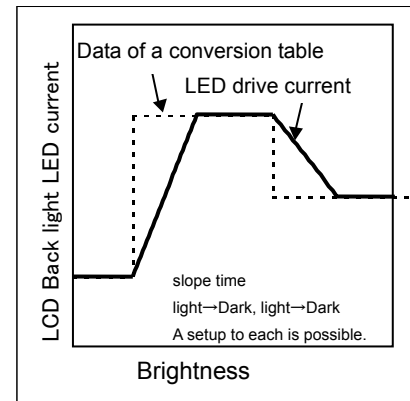
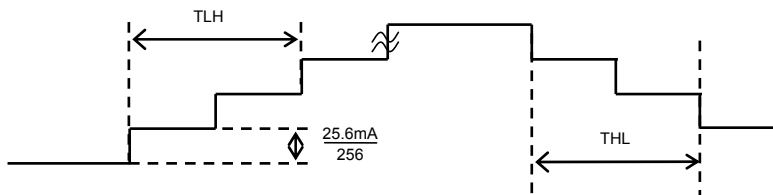

- The slope method at the time of the change in Auto Luminous control mode and register setting mode. It can choose.

Once LED current is set to 0mA at Auto Luminous control mode at the time of a change at the time of MDCIR=1, it transits according to the slope time set up by TLH.

Bit : MDCIR

- LED current data can be read through I²C.

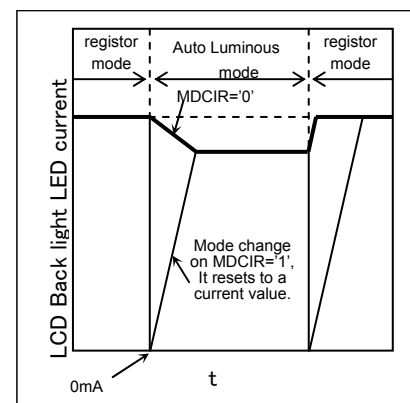

10. Back light current value External adjustmen 1

- Adjustment of the back light current which synchronized with the terminal input instead of timing of register writing is possible.
- By OSYNCEN=0, the amount of offset beforehand set as the register is reflected in LED driver current synchronizing (*) with an external terminal (OSYNC).
 (*) The time of the maximum OSSLP / 2 is taken for LCD back light LED current to start change, since it re-timing by the internal clock in any case.
 Bit : IOFS(5:0)

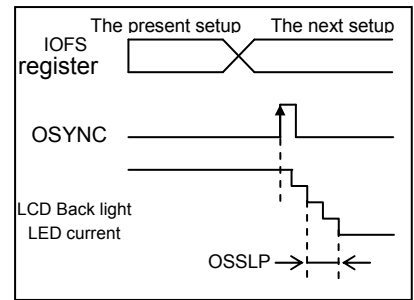

When OSYNCEN=0

- The slope function is carried in the offset current. A slope sets up the change time per 2/256 step. Switching time is common with standup/falling.
 Bit : OSSLP(2:0)

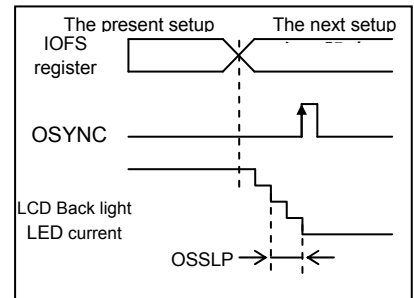
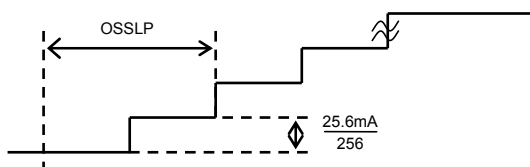

WHEN OSYNCEN=1

11. Back light current value External adjustmen 2

- If a permission is granted by register setup, the PWM drive by the external terminal (WPWMIN) is possible.
 Bit : WPWMEN
- It becomes PWM operation which used the back light current by a register setup or automatic Luminous control as the base, and is the the best for the brightness compensation by external control.

WPWMEN	WPWMIN	Back light current
0	L	Normal operation
0	H	Normal operation
1	L	Compulsion OFF
1	H	Normal operation

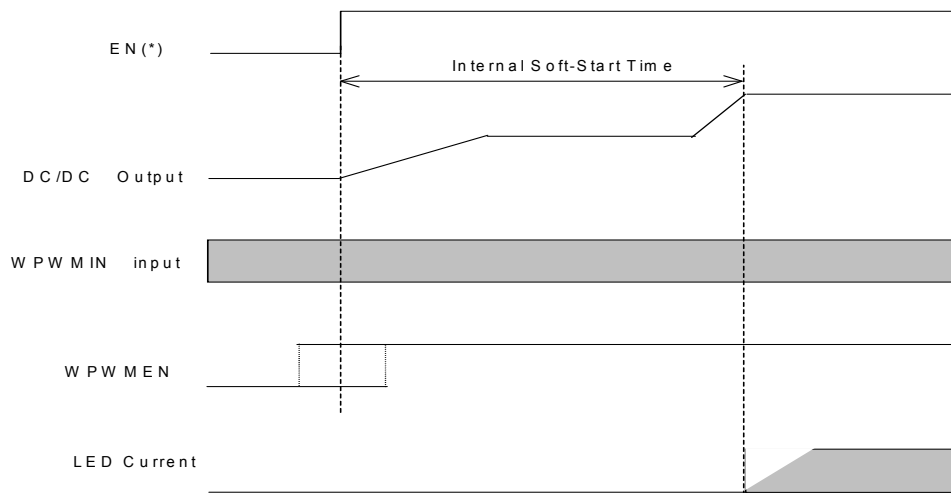

EN(*) : it means "MLEDEN" or "W*EN" or "RGB*EN" or "RGB*OS".
 (case of setting for RGB LED connect to VOUT)

It is possible to make it a WPWMIN input and WPWMEN=1 in front of EN(*).
 A PWM drive becomes effective after the time of an LED current standup.

When rising during PWM operation, as for the standup time of a DC/DC output, only the rate of PWM Duty becomes late. Appearance may be influenced when extremely late frequency and extremely low Duty are inputted.

Please secure 50 μs or more of H sections at the time of PWM pulse Force.

12. Key Backlight Binary Judgment

Capable of comparing luminosity factor data with judgment threshold value with a hysteresis to determine binary judgment for illumination intensity.

- Available for key backlight ON/OFF control based on illumination intensity.
- Sets a threshold value and a hysteresis via the registers.
 Bit name: CTH(3:0)
 Bit name: CHYS(1:0)

The threshold value and hysteresis must meet the following condition:
 CTH setting \geq CHYS setting

Example: The backlight turns on with an illumination intensity of 7 and turns off with an illumination intensity of 5.
 CTH[3:0]=7h CHYS[1:0]=1h

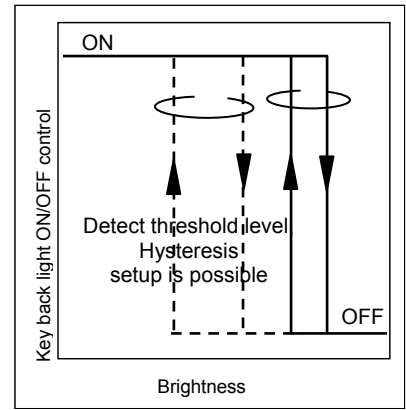

13. Key Backlight PWM Control

- Outputs ON or OFF for binary judgment via the KBLT terminal after PWM processing.
- Allows up to 16 levels of MAX Duty to be set in the register via PWM.
 Bit name: MDTY (3:0)

Allows a slope time to be set in the register via PWM.

16 levels of duties prepared as MAX Duty are sequentially stepped at KBSLP time intervals.

Bit name: KBSLP (1:0)

(This function is effective when KBLT serves for GPO as well as binary judgment.)

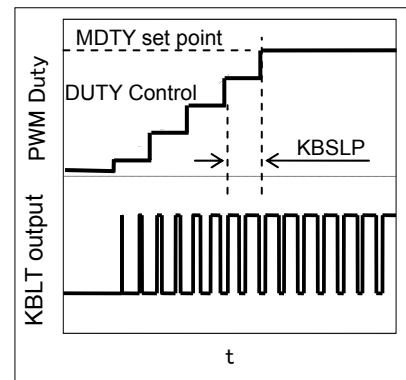

* waveform in this description represents an operation image and does not indicate an absolute value accurately.

●Description of REG Operations

REG control method

ON/OFF control and normal mode/low power consumption mode control available for both register settings and terminal input

REG*ON (Register)	REG*EN (Terminal)	REG* ON/OFF control
0	L	OFF
0	H	ON
1	L	ON
1	H	ON

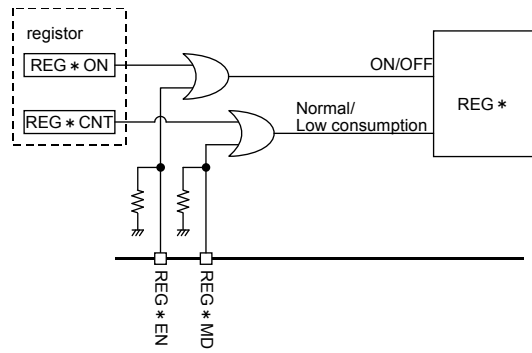

REG control Equivalent circuit diagram

REG * CNT	REG * MD	REG *
0	L	Low consumption
0	H	Normal
1	L	Normal
1	H	Normal

REG2VSEL	REG2
L	1.8V
H	1.5V

* 1 or 2 are shown.

About REG* (I/O voltage) activation

When REG* is output as a VIO voltage, activation must take place as shown below.

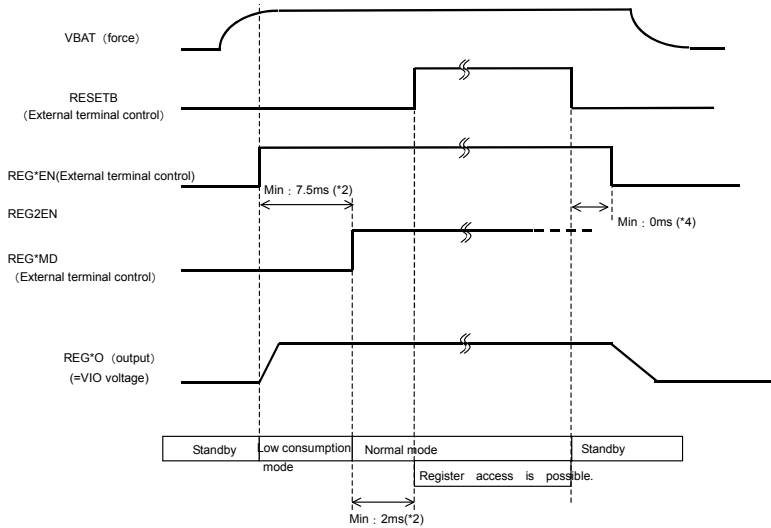

- (*1) This sequence is the case where REG*O is used as I/O voltage. When you carry out external force of the I/O voltage, please start as follows in consideration of the specification of an external power supply.
- (*2) When low consumption mode is unnecessary, REG2 EN=REG2MD (simultaneous control) is possible. However, please take into consideration the REG2 standby time (Min:2ms) at the time of the normal mode in that case.
- (*3) REG* should perform release of RESETB at the time of the normal mode.
- (*4) The simultaneous timing of REG*EN="L" and RESETB="L" is also OK. However, it is prohibition to carry out REG*EN="L" before RESETB="L".

When using an external power supply as VIO voltage, it is necessary to start as follows.

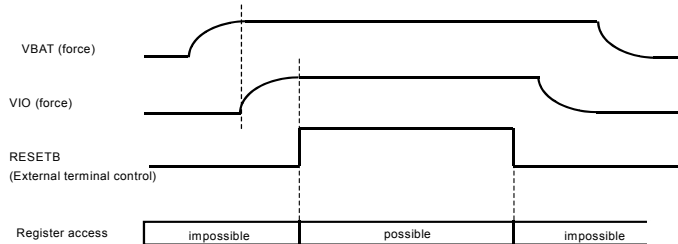

Please perform release of RESETB after the standup of VIO and VGPIO.
It is prohibition to bring down VIO and VGPIO before RESETB="L".
Moreover, when VIO and VGPIO are another power supplies, please start VIO voltage first.

●Description of DC/DC Operations

Activation

The DC/DC circuit is activated when any LED is subject to lighting control (DCDCFON=0). (However, this is true only when the output (VOUT) of the DC/DC circuit is set as a LED connection destination.) A soft start function is available to prevent the rush current at DC/DC circuit activation. Note that voltage should apply to both VBAT and VIO as follows:

DCDCMD=1 must be set in the fixed voltage mode and DCDCMD=DCDCFON=1 must be set when DCDC output takes place regardless of LEDs.

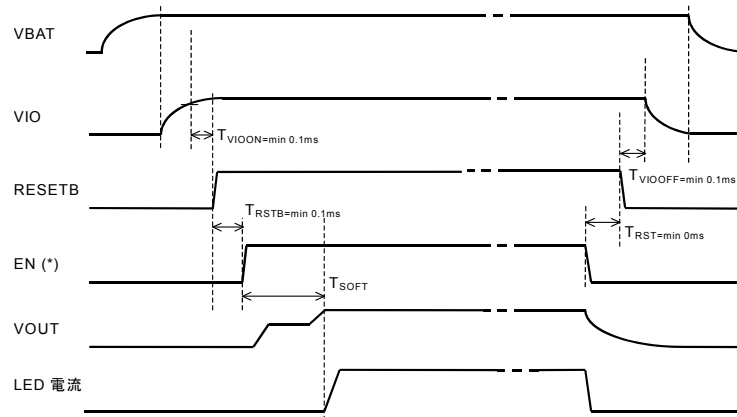

(*) An EN signal means the following in the upper figure.

EN = "MLEDEN" or "W * EN" or "RGB * EN" or "RGB * OS"

(= LED The LED lighting control of a setup of connection VOUT)

But, as for $T_a > T_{TSD}$ (typ : 195° C), a protection function functions, and an EN signal doesn't become effective.

T_{SOFT} changes by the capacitor connected to VOUT and inside OSC.

T_{SOFT} is Typ 200 μs (when the output capacitor of VOUT =1.0 μF).

Overvoltage protection/Overcurrent protection

The DC/DC circuit output (VOUT) is provided with an overvoltage protection function and an overcurrent protection function.

VOUT overvoltage detection voltage: approx. 6.0V (during a VOUT voltage rise)

A detection voltage has a hysteresis and its detection cancel voltage is approx. 5.75V (reference design value). In addition, when the VOUT output is short-circuited to GND, the leak current is suppressed via the overcurrent protection function.

Mode transition

A step-up (pressure rising) multiple switches automatically depending on the VBAT voltage and VOUT terminal voltage.

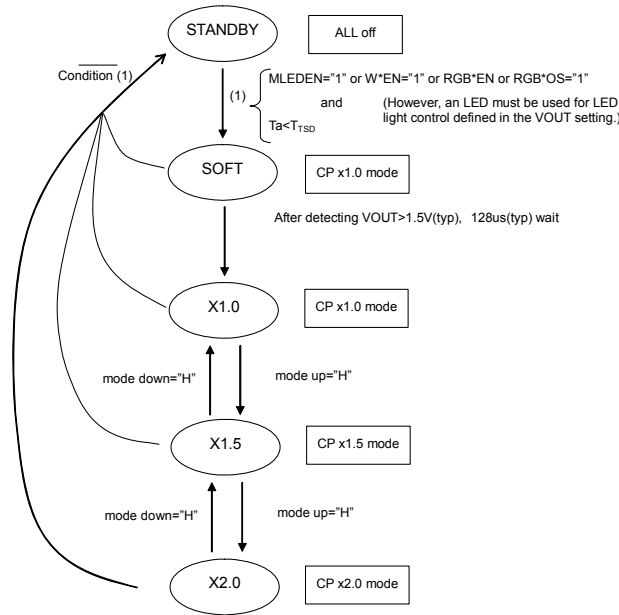

The charge pump mode transits as follows.

<Mode transition: x1.0 → x1.5 → x2.0>

VBAT and VOUT are compared and mode transition is allowed only when the following conditions are satisfied.

Mode transition from x1.0 to x1.5
 $VBAT \leq VOUT + (Ron10 \times I_{out})$
 (LED terminal feedback: $VOUT = Vf + 0.2(Typ)$)
 Mode transition from x1.5 to x2.0
 $VBAT \times 1.5 \leq VOUT + (Ron15 \times I_{out})$
 (LED terminal feedback: $VOUT = Vf + 0.2(Typ)$)

Where, Ron10 and Ron15 represent a 0n resistance at a charge pump.

Ron10=1Ω (Typ), Ron15=5Ω (Typ) (design value)

<Mode transition: x2.0 → x1.5 → x1.0>

VOUT and VBAT rates are detected and mode transition is performed only when a prescribed rate is exceeded.

The rates are as follows:

Mode transition from x1.5 to x1.0
 $VBAT/VOUT = 1.07$ (design value)
 Mode transition from x2.0 to x1.5
 $VBAT/VOUT = 0.96$ (design value)

●Description of other operations

1.Reset

There are two types of reset: software reset and hardware reset.

(1) Software reset

- Setting the register (SFTRST) to “1” causes all the registers to be initialized.
- The registers subject to software reset automatically return to zero (Auto Return 0).

(2) Hardware reset

- Changing the RESETB terminal setting from “H” to “L” causes a state subject to hardware reset.
- Attempting hardware reset causes the states of all registers and output terminals to be initialized to their initial values, so that address reception is entirely stopped.
- Attempting reset in the hardware reset state causes the RESETB terminal state to change from “L” to “H” and vice versa.
- The RESETB terminal is provided with a filter circuit and a duration of 5 μ s or less with the terminal set to “L” is not recognized as hardware reset.

(3) Reset sequence

- When hardware reset is attempted during software reset, software reset is already cleared when hardware reset is cleared (because the software reset initial value is 0).

2.Thermal shutdown

A thermal shutdown function is effective in the following block.

DC/DC (Charge pump)
LED driver
REG1,2 (Normal mode)
SBIAS

The thermal shutdown function is activated when the detected temperature is approx. 195°C.

The detected temperature has a hysteresis and the detection cancel temperature is approx. 175°C (reference value in design).

3. I/O portion

While the RESETB terminal is in “L” state, no input signal is propagated to the IC logic portion because SDA and SCL input buffer operations are all stopped.

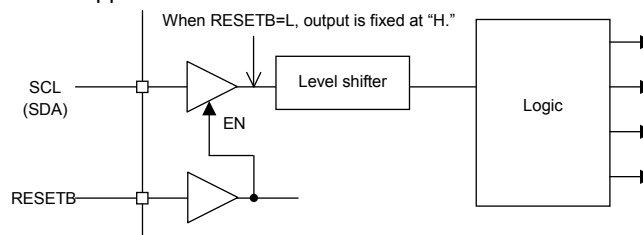

Special care should be taken because a current path may be formed via a terminal protection diode, depending on an I/O power-on sequence or an input level.

4. About the pin management of the function that isn't used and test pins

Setting it as follows is recommended with the test pin and the pin which isn't used.

Set up pin referring to the “Equivalent circuit diagram” so that there may not be a problem under the actual use.

T1, T2, T3	Short to GND because pin for test
T4	OPEN because pin for test
Non-used LED Pin	Short to GND (Must) But, the setup of a register concerned with LED that isn't used is prohibited.
Digital input terminal	Short to GND (A terminal with built-in Pull-Down resistance is also included.)
VGPIO	When you do not use all GPIO channels and a KBLT output, please short-circuit to a ground in VGPIO, GPIO 1-4, and all the 32KIN.
32KIN	When you do not use GPI, please short-circuit to a ground.
GPIO1~4	PulDown with resistance of about 100k Ω (When not using all of GPIO 1-4 and KBLT, it is short-circuiting VGPIO to a ground, and Pull-Down resistance can be omitted)
KBLT	Although Pull-Down is built in, it opens for an output.
INTB ,REG10, REG20	It opens for an output.

●Operation Settings (Flow Example)

1. Backlight: Auto luminous Mode

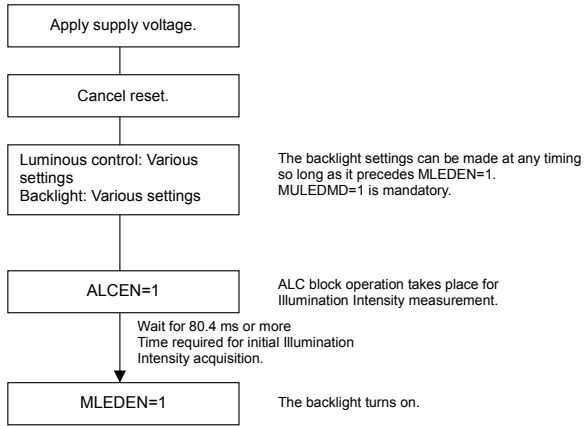

MLEDEN=0 must be set first when the backlight is off.

2. Key Backlight Control at Opening/Closing

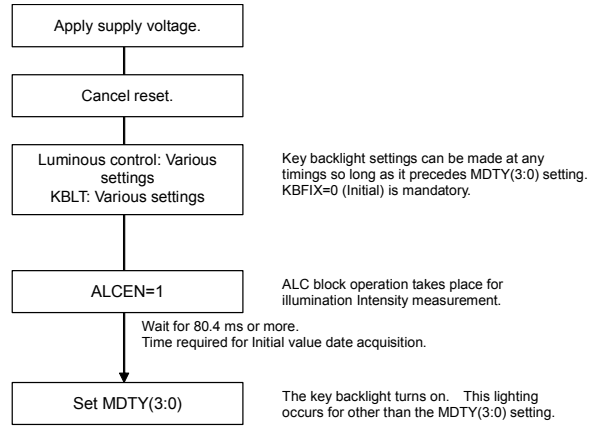

MDTY(3:0) must be set first when the backlight is off.

3. Backlight: Fade-in/Fade-out

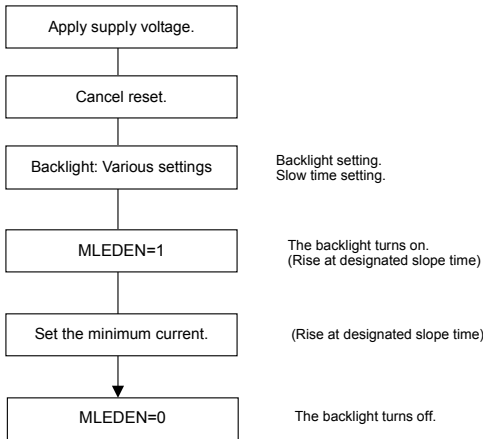

●PCB pattern of the Power dissipation measuring board

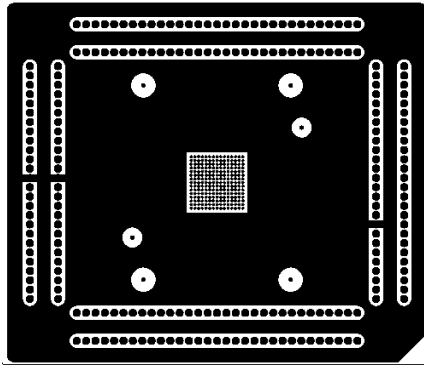

1st layer(component)

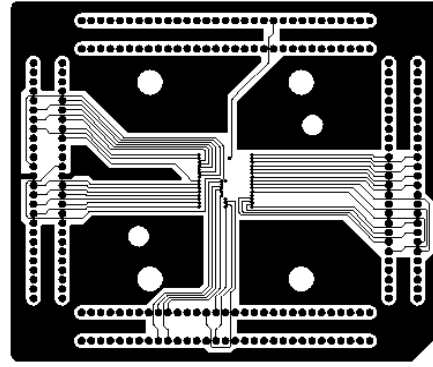

2nd layer

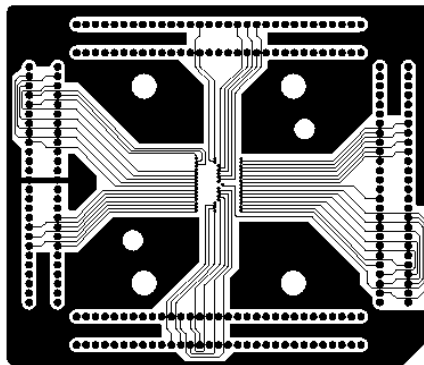

3rd layer

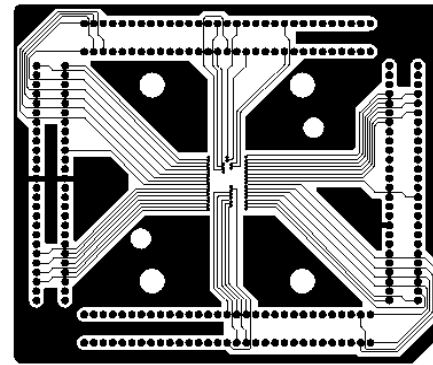

4th layer

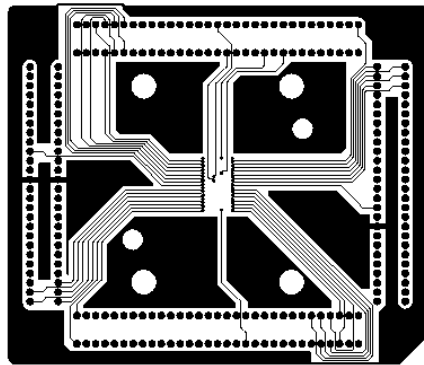

5th layer

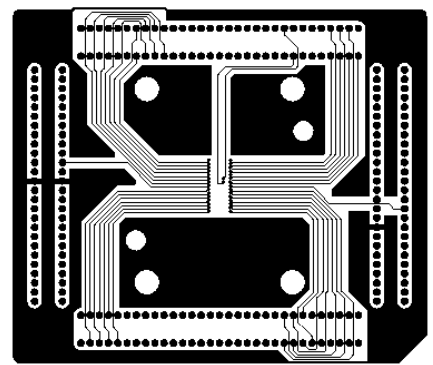

6th layer

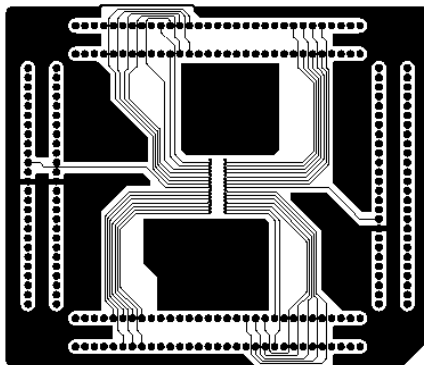

7th layer

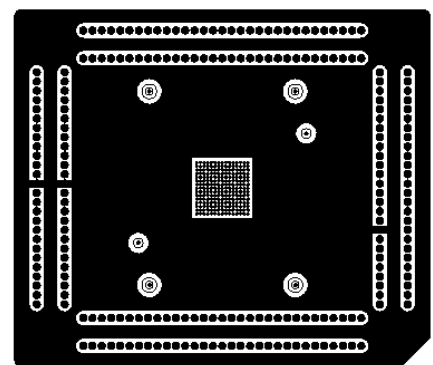

8th layer (solder)

●Notes for use

- (1) Absolute Maximum Ratings
An excess in the absolute maximum ratings, such as supply voltage, temperature range of operating conditions, etc., can break down devices, thus making impossible to identify breaking mode such as a short circuit or an open circuit. If any special mode exceeding the absolute maximum ratings is assumed, consideration should be given to take physical safety measures including the use of fuses, etc.
- (2) Power supply and ground line
Design PCB pattern to provide low impedance for the wiring between the power supply and the ground lines. Pay attention to the interference by common impedance of layout pattern when there are plural power supplies and ground lines. Especially, when there are ground pattern for small signal and ground pattern for large current included the external circuits, please separate each ground pattern. Furthermore, for all power supply pins to ICs, mount a capacitor between the power supply and the ground pin. At the same time, in order to use a capacitor, thoroughly check to be sure the characteristics of the capacitor to be used present no problem including the occurrence of capacity dropout at a low temperature, thus determining the constant.
- (3) Ground voltage
Make setting of the potential of the ground pin so that it will be maintained at the minimum in any operating state. Furthermore, check to be sure no pins are at a potential lower than the ground voltage including an actual electric transient.
- (4) Short circuit between pins and erroneous mounting
In order to mount ICs on a set PCB, pay thorough attention to the direction and offset of the ICs. Erroneous mounting can break down the ICs. Furthermore, if a short circuit occurs due to foreign matters entering between pins or between the pin and the power supply or the ground pin, the ICs can break down.
- (5) Operation in strong electromagnetic field
Be noted that using ICs in the strong electromagnetic field can malfunction them.
- (6) Input pins
In terms of the construction of IC, parasitic elements are inevitably formed in relation to potential. The operation of the parasitic element can cause interference with circuit operation, thus resulting in a malfunction and then breakdown of the input pin. Therefore, pay thorough attention not to handle the input pins, such as to apply to the input pins a voltage lower than the ground respectively, so that any parasitic element will operate. Furthermore, do not apply a voltage to the input pins when no power supply voltage is applied to the IC. In addition, even if the power supply voltage is applied, apply to the input pins a voltage lower than the power supply voltage or within the guaranteed value of electrical characteristics.
- (7) External capacitor
In order to use a ceramic capacitor as the external capacitor, determine the constant with consideration given to a degradation in the nominal capacitance due to DC bias and changes in the capacitance due to temperature, etc.
- (8) Thermal shutdown circuit (TSD)
This LSI builds in a thermal shutdown (TSD) circuit. When junction temperatures become detection temperature or higher, the thermal shutdown circuit operates and turns a switch OFF. The thermal shutdown circuit, which is aimed at isolating the LSI from thermal runaway as much as possible, is not aimed at the protection or guarantee of the LSI. Therefore, do not continuously use the LSI with this circuit operating or use the LSI assuming its operation.
- (9) Thermal design
Perform thermal design in which there are adequate margins by taking into account the permissible dissipation (Pd) in actual states of use.
- (10) LDO
Use each output of LDO by the independence. Don't use under the condition that each output is short-circuited because it has the possibility that an operation becomes unstable.
- (11) About the pin for the test, the un-use pin
Prevent a problem from being in the pin for the test and the un-use pin under the state of actual use. Please refer to a function manual and an application notebook. And, as for the pin that doesn't specially have an explanation, ask our company person in charge.
- (12) Rush Current
Rush current may flow in instant in the internal logic unfixed state by the power supply injection order and delay. Therefore, be careful of power supply coupling capacity, a power supply and the width of grand pattern wiring, and leading about.
- (13) About the function description or application note or more.
The function manual and the application notebook are the design materials to design a set. So, the contents of the materials aren't always guaranteed. Please design application by having fully examination and evaluation include the external elements.

●Power Dissipation (On the ROHM's standard board)

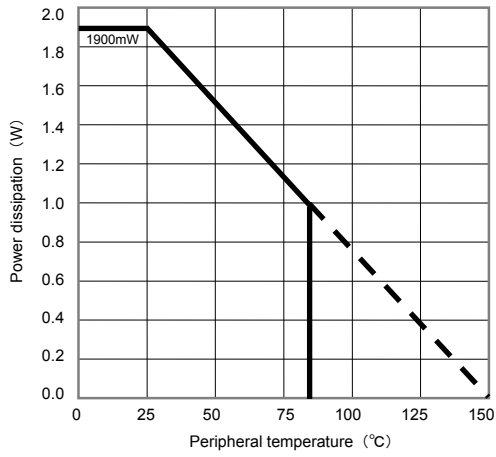

Information of the ROHM's standard board
Material : glass-epoxy
Size : 50mm×58mm×1.75mm (8Layer)
Pattern of the board: Refer to it that goes later.

●Ordering part number

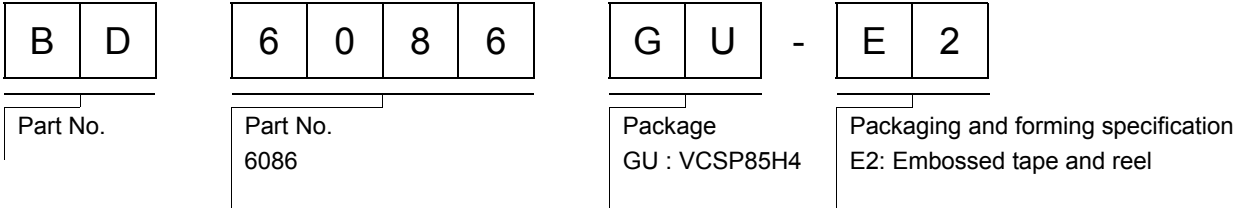

VCSP85H4(BD6086GU)

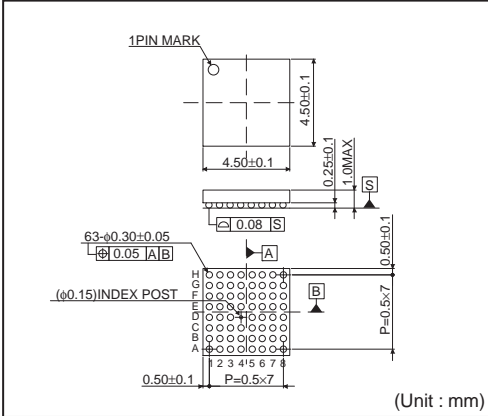

<Tape and Reel information>

Tape	Embossed carrier tape
Quantity	2500pcs
Direction of feed	E2 (The direction is the 1pin of product is at the upper left when you hold reel on the left hand and you pull out the tape on the right hand)

* Order quantity needs to be multiple of the minimum quantity.

Notes

No copying or reproduction of this document, in part or in whole, is permitted without the consent of ROHM Co.,Ltd.

The content specified herein is subject to change for improvement without notice.

The content specified herein is for the purpose of introducing ROHM's products (hereinafter "Products"). If you wish to use any such Product, please be sure to refer to the specifications, which can be obtained from ROHM upon request.

Examples of application circuits, circuit constants and any other information contained herein illustrate the standard usage and operations of the Products. The peripheral conditions must be taken into account when designing circuits for mass production.

Great care was taken in ensuring the accuracy of the information specified in this document. However, should you incur any damage arising from any inaccuracy or misprint of such information, ROHM shall bear no responsibility for such damage.

The technical information specified herein is intended only to show the typical functions of and examples of application circuits for the Products. ROHM does not grant you, explicitly or implicitly, any license to use or exercise intellectual property or other rights held by ROHM and other parties. ROHM shall bear no responsibility whatsoever for any dispute arising from the use of such technical information.

The Products specified in this document are intended to be used with general-use electronic equipment or devices (such as audio visual equipment, office-automation equipment, communication devices, electronic appliances and amusement devices).

The Products specified in this document are not designed to be radiation tolerant.

While ROHM always makes efforts to enhance the quality and reliability of its Products, a Product may fail or malfunction for a variety of reasons.

Please be sure to implement in your equipment using the Products safety measures to guard against the possibility of physical injury, fire or any other damage caused in the event of the failure of any Product, such as derating, redundancy, fire control and fail-safe designs. ROHM shall bear no responsibility whatsoever for your use of any Product outside of the prescribed scope or not in accordance with the instruction manual.

The Products are not designed or manufactured to be used with any equipment, device or system which requires an extremely high level of reliability the failure or malfunction of which may result in a direct threat to human life or create a risk of human injury (such as a medical instrument, transportation equipment, aerospace machinery, nuclear-reactor controller, fuel-controller or other safety device). ROHM shall bear no responsibility in any way for use of any of the Products for the above special purposes. If a Product is intended to be used for any such special purpose, please contact a ROHM sales representative before purchasing.

If you intend to export or ship overseas any Product or technology specified herein that may be controlled under the Foreign Exchange and the Foreign Trade Law, you will be required to obtain a license or permit under the Law.



Thank you for your accessing to ROHM product informations.
More detail product informations and catalogs are available, please contact us.

ROHM Customer Support System

<http://www.rohm.com/contact/>