

Structure Silicon Monolithic Integrated Circuit

Product Name Compound LED Driver for cellular phone

Type **BD6083GUL**

Features Charge pump system DC/DC
LED Driver for LCD Backlight (3~6ch)
Ambient light sensor interface
Series Regulator (4ch)

● Absolute Maximum Ratings (Ta=25 °C)

Parameter	Symbol	Limits	Unit
Maximum Applied voltage	VMAX	7	V
Power Dissipation	Pd	1280 note1)	mW
Operating Temperature Range	Topr	-30 ~ +85	°C
Storage Temperature Range	Tstg	-55 ~ +150	°C

note1) Power dissipation deleting is 10.24mW/ °C, when it's used in over 25 °C.

(It's deleting is on the board that is ROHM's standard)

Dissipation by LSI should not exceed tolerance level of Pd.

● Operating conditions (VBAT≥VIO, Ta=-30~85 °C)

Parameter	Symbol	Limits	Unit
VBAT input voltage	VBAT	2.7~5.5	V
VIO pin voltage	VIO	1.65~3.3	V

* Radiation-proof is not designed.

●Electrical Characteristics (Unless otherwise specified, Ta=25°C, VBAT=3.6V, VIO=1.8V)

Parameter	Symbol	Min.	Typ.	Max.	Unit	Condition
【Circuit Current】						
VBAT Circuit current 1	IBAT1	-	0.1	3.0	μA	RESETB=0V, VIO= 0V
VBAT Circuit current 2	IBAT2	-	0.5	3.0	μA	RESETB=0V, VIO=1.8V
VBAT Circuit current 3	IBAT3	-	61	65	mA	DC/DC x1 mode, Io=60mA VBAT=4.0V
VBAT Circuit current 4	IBAT4	-	92	102	mA	DC/DC x1.5 mode, Io=60mA VBAT=3.6V
VBAT Circuit current 5	IBAT5	-	123	140	mA	DC/DC x2 mode, Io=60mA VBAT=2.7V
VBAT Circuit current 6	IBAT6	-	0.25	1.0	mA	ALC Operating ALCEN=1, AD cycle=0.5s setting Except sensor current
VBAT Circuit current 7	IBAT7	-	90	150	μA	LDO1,2=ON, ILDO=0mA
VBAT Circuit current 8	IBAT8	-	90	150	μA	LDO3,4=ON, ILDO=0mA
【LED Driver】						
LED current Step (DC Setup)	ILEDSTP1	128			Step	LED1~6
LED current Step (At slope)	ILEDSTP2	256			Step	LED1~6
LED Maximum setup current	IMAXWLED	-	25.6	-	mA	LED1~6
LED current accuracy	IWLED	-7%	15	+7%	mA	I _{LED} =15mA setting V _{LED} =1.0V
LED current Matching	ILEDMT	-	-	4	%	Between LED1~6 at V _{LED} =1.0V, I _{LED} =15mA
LED OFF Leak current	ILKLED	-	-	1.0	μA	V _{LED} =4.5V
【DC/DC (Charge Pump)】						
Output Voltage	VoCP	-	Vf+0.2	Vf+0.25	V	Vf is forward voltage of LED
Drive ability	IOUT	-	-	150	mA	VBAT≥3.2V, VOUT=3.9V
Switching frequency	fosc	0.8	1.0	1.2	MHz	
Over Voltage Protection detect voltage	OVP	-	5.6	-	V	
Over Current Protection detect Current	OCP	-	250	375	mA	VOUT=0V
【Sensor Interface】						
SBIAS Output Voltage	VoS	2.85	3.0	3.15	V	Io=200μA
SBIAS Maximum Output Current	IomaxS	30	-	-	mA	
SBIAS Discharge resister at OFF	ROFFS	-	1.0	1.5	kΩ	
SSENS Input range	VISS	0	-	VoS × 255/256	V	
ADC resolution	ADRES	8			bit	
ADC integral calculus non-linearity	ADINL	-3	-	+3	LSB	
ADC differential calculus non-linearity	ADDNL	-1	-	+1	LSB	
【Regulator】						
Output voltage	Vo1	1.164	1.20	1.236	V	Io=50mA
		1.261	1.30	1.339	V	Io=50mA
		1.455	1.50	1.545	V	Io=50mA
		1.552	1.60	1.648	V	Io=50mA
		1.746	1.80	1.854	V	Io=50mA
		2.134	2.20	2.266	V	Io=50mA
		2.328	2.40	2.472	V	Io=50mA
		2.425	2.50	2.575	V	Io=50mA
		2.522	2.60	2.678	V	Io=50mA
		2.619	2.70	2.781	V	Io=50mA
		2.716	2.80	2.884	V	Io=50mA
		2.813	2.90	2.987	V	Io=50mA
		2.910	3.00	3.090	V	Io=50mA
		3.007	3.10	3.193	V	Io=50mA
		3.104	3.20	3.296	V	Io=50mA
3.201	3.30	3.399	V	Io=50mA		

● Electrical Characteristics ((Unless otherwise specified, Ta=25°C, VBAT=3.6V, VIO=1.8V)

Parameter	Symbol	Min.	Typ.	Max.	Unit	Condition
【Regulator】						
Output Current	Io1	-	-	150	mA	Vo=* Refer to following
Dropout Voltage	Vsat1	-	0.2	0.3	V	VBAT=2.5V, Io=150mA, Vo=2.8V setting
Load stability	ΔVo11	-	10	60	mV	Io=1~150mA, Vo=* Refer to following
Input voltage stability	ΔVo12	-	10	60	mV	VBAT=3.4~4.5V, Io=50mA Vo=* Refer to following
Ripple Rejection Ratio	RR1	-	65	-	dB	f=100Hz, Vin=200mVp-p, Vo=1.2V setting Io=50mA, BW=20Hz~20kHz
Short circuit current limit	Ilim1	-	200	400	mA	Vo=0V
Discharge resistor at OFF	ROFF1	-	1.0	1.5	kΩ	
【SDA, SCL】 (I²C Interface)						
L level input voltage	VILI	-0.3	-	0.25 × VIO	V	
H level input voltage	VIHI	0.75 × VIO	-	VBAT +0.3	V	
Hysteresis of Schmitt trigger input	Vhysl	0.05 × VIO	-	-	V	
L level output voltage	VOLI	0	-	0.3	V	SDA Pin, IOL=3 mA
Input current	Iinl	-	-	1	μA	Input Voltage = 0.1×VIO~0.9×VIO
【RESETB】 (CMOS Input Pin)						
L level input voltage	VILR	-0.3	-	0.25 × VIO	V	
H level input voltage	VIHR	0.75 × VIO	-	VBAT +0.3	V	
Input current	IinR	-	-	1	μA	Input Voltage = 0.1×VIO~0.9×VIO
【WPWMIN】 (NMOS Input Pin)						
L level input voltage	VILA	-0.3	-	0.3	V	
H level input voltage	VIHA	1.4	-	VBAT +0.3	V	
Input Current	IinA	-	3.6	10	μA	Input Voltage = 1.8V
PWM input minimum High pulse width	PWmin	120	-	-	μs	WPWMIN Pin
【GC1, GC2】 (Sensor Gain Control CMOS Output Pin)						
L level output voltage	VOLS	-	-	0.2	V	IOL=1mA
H level output voltage	VOHS	VoS -0.2	-	-	V	IOH=1mA

*Regulator (LDO1) : Vo=1.8V Setting
*Regulator (LDO2) : Vo=2.5V Setting

*Regulator (LDO3) : Vo=1.8V Setting
*Regulator (LDO4) : Vo=2.8V Setting

● Package

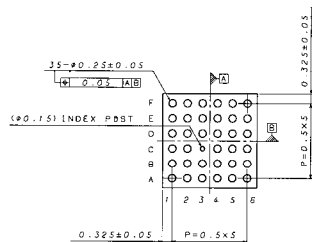
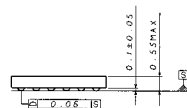
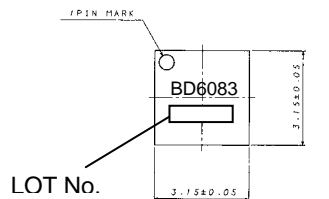

VCSP50L3 (36 Pin)
(Unit:mm)

● Block Diagram

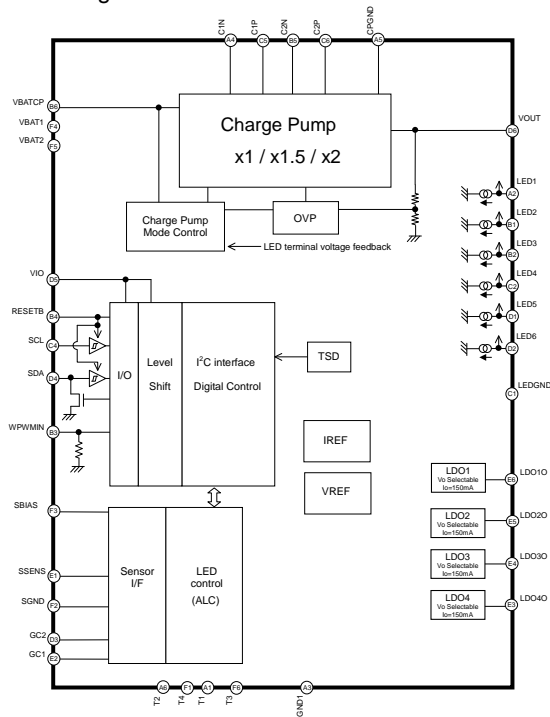

● Pin Functions

PIN	Pin Name	PIN	Pin Name
B6	VBATCP	D6	VOUT
F4	VBAT1	A2	LED1
F5	VBAT2	B1	LED2
A1	T1	B2	LED3
A6	T2	C2	LED4
F6	T3	D1	LED5
F1	T4	D2	LED6
D5	VIO	F3	SBIAS
B4	RESETB	E1	SSENS
D4	SDA	E2	GC1
C4	SCL	D3	GC2
A5	CPGND	F2	SGND
A3	GND1	B3	WPWMIN
C1	LEDGND	E6	LDO10
A4	C1N	E5	LDO20
C5	C1P	E4	LDO30
B5	C2N	E3	LDO40
C6	C2P		

● Cautions on use

(1) Absolute Maximum Ratings

An excess in the absolute maximum ratings, such as supply voltage, temperature range of operating conditions, etc., can break down devices, thus making impossible to identify breaking mode such as a short circuit or an open circuit. If any special mode exceeding the absolute maximum ratings is assumed, consideration should be given to take physical safety measures including the use of fuses, etc.

(2) Power supply and ground line

Design PCB pattern to provide low impedance for the wiring between the power supply and the ground lines. Pay attention to the interference by common impedance of layout pattern when there are plural power supplies and ground lines. Especially, when there are ground pattern for small signal and ground pattern for large current included the external circuits, please separate each ground pattern. Furthermore, for all power supply pins to ICs, mount a capacitor between the power supply and the ground pin. At the same time, in order to use a capacitor, thoroughly check to be sure the characteristics of the capacitor to be used present no problem including the occurrence of capacity dropout at a low temperature, thus determining the constant.

(3) Ground voltage

Make setting of the potential of the ground pin so that it will be maintained at the minimum in any operating state. Furthermore, check to be sure no pins are at a potential lower than the ground voltage including an actual electric transient.

(4) Short circuit between pins and erroneous mounting

In order to mount ICs on a set PCB, pay thorough attention to the direction and offset of the ICs. Erroneous mounting can break down the ICs. Furthermore, if a short circuit occurs due to foreign matters entering between pins or between the pin and the power supply or the ground pin, the ICs can break down.

(5) Operation in strong electromagnetic field

Be noted that using ICs in the strong electromagnetic field can malfunction them.

(6) Input pins

In terms of the construction of IC, parasitic elements are inevitably formed in relation to potential. The operation of the parasitic element can cause interference with circuit operation, thus resulting in a malfunction and then breakdown of the input pin. Therefore, pay thorough attention not to handle the input pins, such as to apply to the input pins a voltage lower than the ground respectively, so that any parasitic element will operate. Furthermore, do not apply a voltage to the input pins when no power supply voltage is applied to the IC. In addition, even if the power supply voltage is applied, apply to the input pins a voltage lower than the power supply voltage or within the guaranteed value of electrical characteristics.

(7) External capacitor

In order to use a ceramic capacitor as the external capacitor, determine the constant with consideration given to a degradation in the nominal capacitance due to DC bias and changes in the capacitance due to temperature, etc.

(8) Thermal shutdown circuit (TSD)

This LSI builds in a thermal shutdown (TSD) circuit. When junction temperatures become detection temperature or higher, the thermal shutdown circuit operates and turns a switch OFF. The thermal shutdown circuit, which is aimed at isolating the LSI from thermal runaway as much as possible, is not aimed at the protection or guarantee of the LSI. Therefore, do not continuously use the LSI with this circuit operating or use the LSI assuming its operation.

(9) Thermal design

Perform thermal design in which there are adequate margins by taking into account the permissible dissipation (Pd) in actual states of use.

(10) LDO

Use each output of LDO by the independence. Don't use under the condition that each output is short-circuited because it has the possibility that an operation becomes unstable.

(11) About the pin for the test, the un-use pin

Prevent a problem from being in the pin for the test and the un-use pin under the state of actual use. Please refer to a function manual and an application notebook. And, as for the pin that doesn't specially have an explanation, ask our company person in charge.

(12) About the rush current

For ICs with more than one power supply, it is possible that rush current may flow instantaneously due to the internal powering sequence and delays. Therefore, give special consideration to power coupling capacitance, power wiring, width of ground wiring, and routing of wiring.

(13) About the function description or application note or more.

The function description and the application notebook are the design materials to design a set. So, the contents of the materials aren't always guaranteed. Please design application by having fully examination and evaluation include the external elements.

Notes

No copying or reproduction of this document, in part or in whole, is permitted without the consent of ROHM Co.,Ltd.

The content specified herein is subject to change for improvement without notice.

The content specified herein is for the purpose of introducing ROHM's products (hereinafter "Products"). If you wish to use any such Product, please be sure to refer to the specifications, which can be obtained from ROHM upon request.

Examples of application circuits, circuit constants and any other information contained herein illustrate the standard usage and operations of the Products. The peripheral conditions must be taken into account when designing circuits for mass production.

Great care was taken in ensuring the accuracy of the information specified in this document. However, should you incur any damage arising from any inaccuracy or misprint of such information, ROHM shall bear no responsibility for such damage.

The technical information specified herein is intended only to show the typical functions of and examples of application circuits for the Products. ROHM does not grant you, explicitly or implicitly, any license to use or exercise intellectual property or other rights held by ROHM and other parties. ROHM shall bear no responsibility whatsoever for any dispute arising from the use of such technical information.

The Products specified in this document are intended to be used with general-use electronic equipment or devices (such as audio visual equipment, office-automation equipment, communication devices, electronic appliances and amusement devices).

The Products specified in this document are not designed to be radiation tolerant.

While ROHM always makes efforts to enhance the quality and reliability of its Products, a Product may fail or malfunction for a variety of reasons.

Please be sure to implement in your equipment using the Products safety measures to guard against the possibility of physical injury, fire or any other damage caused in the event of the failure of any Product, such as derating, redundancy, fire control and fail-safe designs. ROHM shall bear no responsibility whatsoever for your use of any Product outside of the prescribed scope or not in accordance with the instruction manual.

The Products are not designed or manufactured to be used with any equipment, device or system which requires an extremely high level of reliability the failure or malfunction of which may result in a direct threat to human life or create a risk of human injury (such as a medical instrument, transportation equipment, aerospace machinery, nuclear-reactor controller, fuel-controller or other safety device). ROHM shall bear no responsibility in any way for use of any of the Products for the above special purposes. If a Product is intended to be used for any such special purpose, please contact a ROHM sales representative before purchasing.

If you intend to export or ship overseas any Product or technology specified herein that may be controlled under the Foreign Exchange and the Foreign Trade Law, you will be required to obtain a license or permit under the Law.



Thank you for your accessing to ROHM product informations.
More detail product informations and catalogs are available, please contact us.

ROHM Customer Support System

<http://www.rohm.com/contact/>