

LVDS Interface ICs

35bit LVDS Receiver

5:35 DeSerializer



BU90R104

No.11057EBT09

●Description

LVDS Interface IC of ROHM "Serializer" "Deserializer" operates from 8MHz to 150MHz wide clock range, and number of bits range is from 35 to 70. Data is transmitted seven times (7X) stream and reduce cable number by 3(1/3) or less. The ROHM's LVDS has low swing mode to be able to expect further low EMI.

●Features

- 1) Five channels of LVDS data stream are converted to 35bits data of parallel LVCMOS level outputs.
- 2) 30bits of RGB output data, 5bits of timing and control output data(HSYNC, VSYNC, DE, CTL1 and CTL2) are transmitted available.
- 3) Support clock frequency from 8MHz up to 112MHz.
- 4) Support consumer video format including 480i, 480P, 720P and 1080i as well.
- 5) Support many kinds of PC video formats such as VGA, SVGA, XGA and SXGA.
- 6) Provide 784Mbps per 1ch or 3.92Gbps per device throughput rate using 112MHz clock rate.
- 7) User programmable LVCMOS data output triggering timing by using either rising or falling edge of clock.
- 8) 30bit LVDS transmitter is recommended to use BU8254KVT.

●Applications

Flat Panel Display

●Absolute maximum ratings

Parameter	Symbol	Ratings		Unit
		Min.	Max.	
Supply voltage	V_{DD}	-0.3	4.0	V
Input voltage	V_{IN}	-0.3	$V_{DD}+0.3$	V
Output voltage	V_{OUT}	-0.3	$V_{DD}+0.3$	V
Storage temperature range	Tstg	-55	125	°C

●Package power

Package	PD(mW)	DERATING(mW/°C) ^{*1}
TQFP64V	700	7.0
	1000 ^{*2}	10.0 ^{*2}

*1 At temperature $T_a > 25^\circ\text{C}$

*2 Package power when mounting on the PCB board.

The size of PCB board :70 × 70 × 1.6(mm³)

The material of PCB board :The FR4 glass epoxy board.(3% or less copper foil area)

●Recommended operating conditions

Parameter	Symbol	Ratings			Unit	Condition
		Min.	Typ.	Max.		
Supply voltage	V_{DD}	2.3	3.3	3.6	V	VDD, LVDD, PVDD
Supply Noise Voltage	V_{NOZ}	-	-	0.1	V	
Operating temperature range	Topr	-20	-	85	°C	Clock frequency from 8MHz up to 90MHz
		0	-	70	°C	Clock frequency from 90MHz up to 112MHz

●Block Diagram

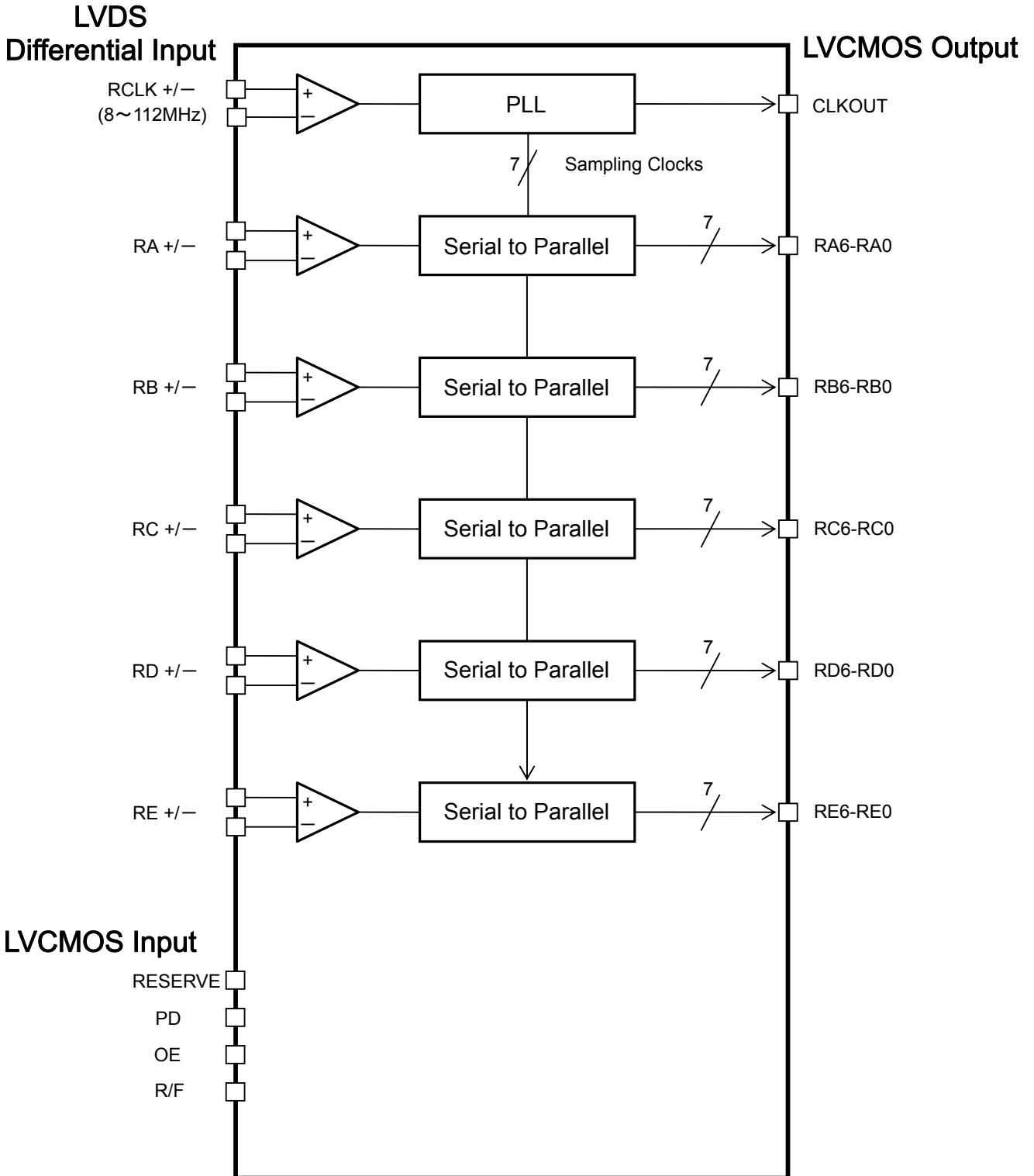

Fig.1 Block Diagram

●TQFP64V Package Specification

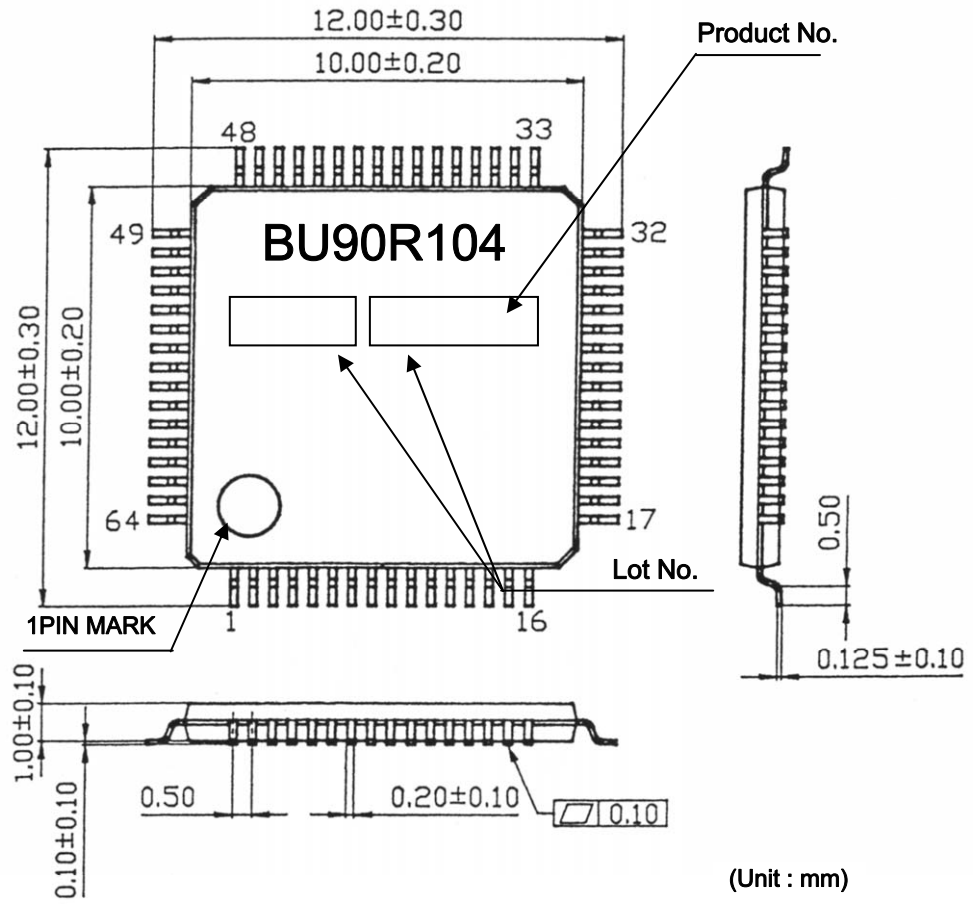

Fig.2 TQFP64V Package

●Pin Diagram

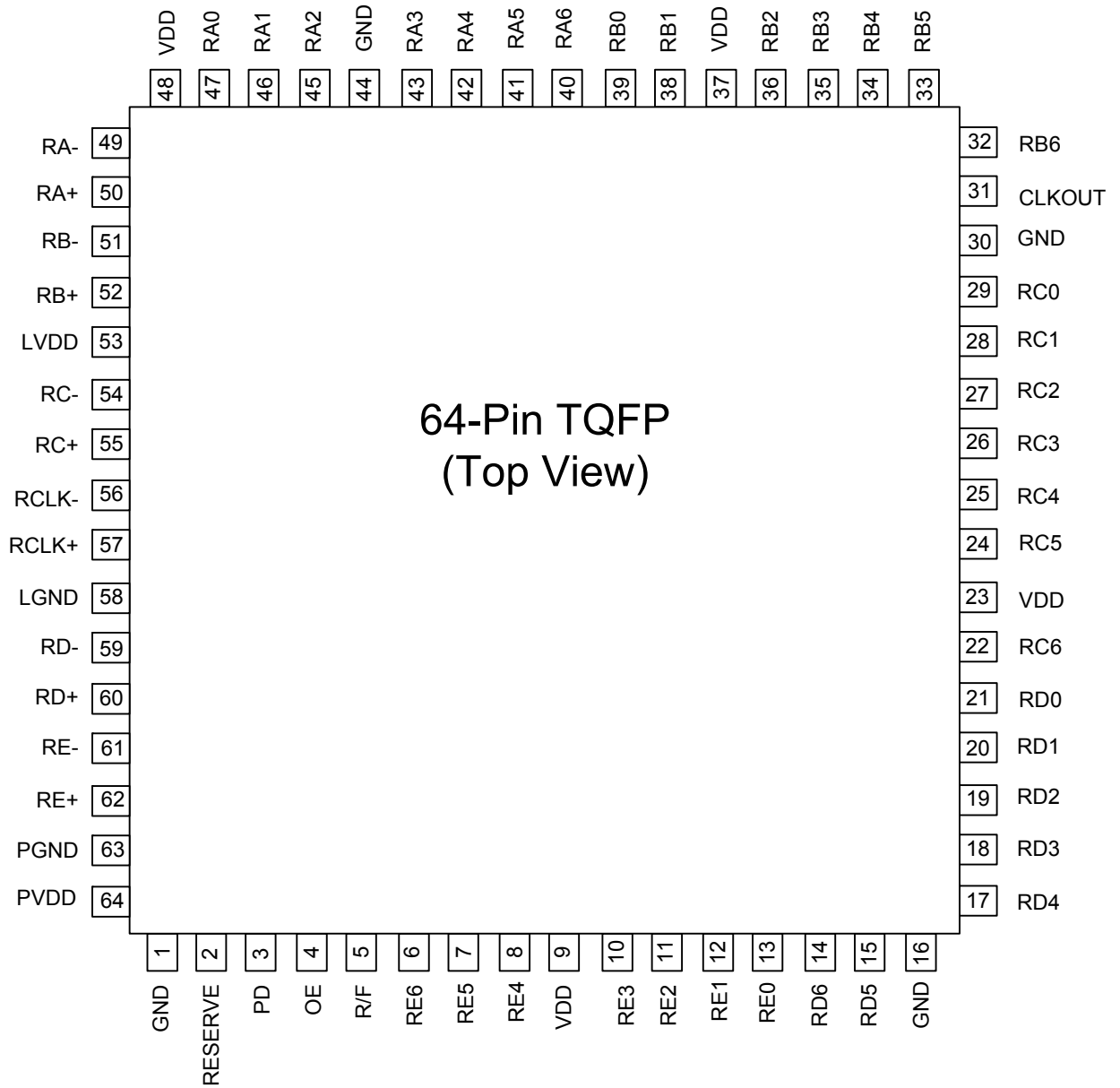

Fig.3 Pin diagram (Top view)

●Pin Description

Pin Name	Pin No.	I/O	Description
RA+, RA-	50,49	LVDS Input	LVDS data input + : Positive input of LVDS data differential pair. - : Negative input of LVDS data differential pair.
RB+, RB-	52,51	LVDS Input	
RC+, RC-	55,54	LVDS Input	
RD+, RD-	60,59	LVDS Input	
RE+, RE-	62,61	LVDS Input	
RCLK+, RCLK-	57,56	LVDS Input	LVDS clock input
RA6~RA0	40,41,42,43, 45,46,47	Output	LVCMOS data outputs.
RB6~RB0	32,33,34,35, 36,38,39	Output	
RC6~RC0	22,24,25,26, 27,28,29	Output	
RD6~RD0	14,15,17,18, 19,20,21	Output	
RE6~RE0	6,7,8,10, 11,12,13	Output	
RESERVE	2	Input	Reserved input must be "Low" for normal operation.
PD	3	Input	Power down input for the internal system. H : Normal operation. L : Power down (All output are "Low").
OE	4	Input	Power down input for the data output driver. H : Output enable (Normal operation). L : Output disable (All outputs are "Hi-Z").
R/F	5	Input	Select input pin for data output clock triggering edge. H : Output data is latched on rising edge. L : Output data is latched on falling edge.
VDD	9,23,37,48	Power	3.3V output driver and digital core power supply pin.
CLKOUT	31	Output	LVCMOS level clock output.
GND	1,16,30,44	Ground	GND pin for both data output driver cells and the digital cores.
LVDD	53	Power	Power supply pin for LVDS inputs.
LGND	58	Ground	Ground pin for LVDS inputs.
PVDD	64	Power	Power supply pin for PLL core.
PGND	63	Ground	Ground pin for PLL core.

●Function Description

PD	R/F	OE	Data output (Rxn) ^{*1}	Clock output
0	0	0	Hi-Z	Hi-Z
0	0	1	All fixed low	Fixed Low
0	1	0	Hi-Z	Hi-Z
0	1	1	All fixed low	Fixed Low
1	0	0	Hi-Z	Hi-Z
1	0	1	Data output	Output data is latched by falling edge of clock.
1	1	0	Hi-Z	Hi-Z
1	1	1	Data output	Output data is latched by rising edge of clock

*1 : Rxn
x = A,B,C,D,E
n = 0,1,2,3,4,5,6

●Electrical Characteristics

■DC Characteristics

OLVCMOS DC character ($V_{DD}=2.3V\sim 3.6V$, $T_a=-20^{\circ}C\sim 85^{\circ}C$)

Parameter	Symbol	Limits			Unit	Conditions
		Min.	Typ.	Max.		
High Input voltage	V_{IH}	$V_{DD} \times 0.8$	-	V_{DD}	V	
Low Input voltage	V_{IL}	0.0	-	$V_{DD} \times 0.2$	V	
High Output voltage	V_{OH}	$V_{DD}-0.5$	-	V_{DD}	V	$I_{OH}=-4mA$ (data) $I_{OH}=-8mA$ (clock)
Low Output voltage	V_{OL}	0.0	-	0.4	V	$I_{OL}=4mA$ (data) $I_{OL}=8mA$ (clock)
Input current	I_{INC}	-	-	± 10	μA	$0V \leq V_{IN} \leq V_{DD}$

OLVDS Receiver DC character ($V_{DD}=2.3V\sim 3.6V$, $T_a=-20^{\circ}C\sim 85^{\circ}C$)

Parameter	Symbol	Limits			Unit	Conditions
		Min.	Typ.	Max.		
Differential input High threshold	V_{TH}	-	-	100	mV	$V_{OC}^{*1}=1.2V$
Differential input Low threshold	V_{TL}	-100	-	-	mV	$V_{OC}^{*1}=1.2V$
Input current	I_{INL}	-	-	± 25	μA	$V_{IN}=2.4V / 0V$ $V_{DD}=3.6V$

*1 Common Mode Voltage

■Supply Current

○Supply current

Parameter	Symbol	Limits		Unit	Conditions	
		Min.	Max.			
Receiver supply current (Gray Scale Pattern)	I_{RCCG}	52	-	mA	$f_{CLKOUT}=90MHz$	$C_L=8pF, V_{DD}=3.3V$
Receiver supply current (Worst Case Pattern)	I_{RCCW}	95	-	mA	$f_{CLKOUT}=90MHz$	$C_L=8pF, V_{DD}=3.3V$
Receiver power down supply current	I_{RCCS}	-	10	μA	PD=L, OE=L	

Gray Scale Pattern

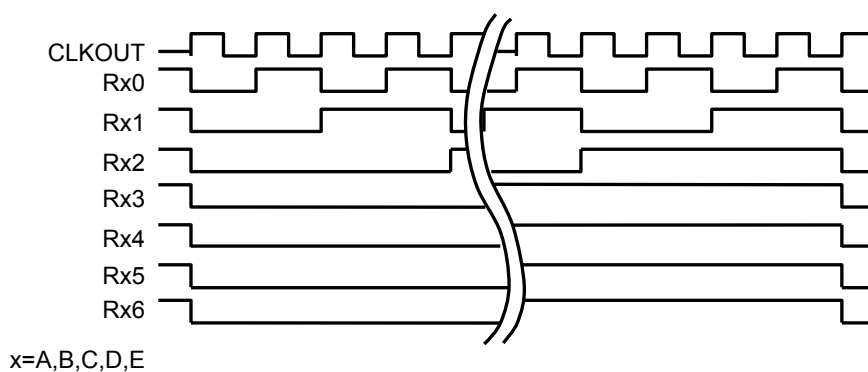

Fig.4 Gray Scale Pattern

Worst Case Pattern (Maximum power condition)

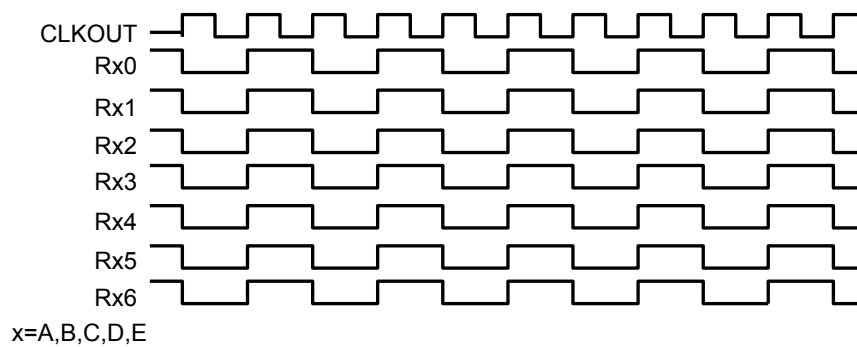

Fig.5 Worst Case Pattern

■ AC Characteristics

○ Switching characteristics

Parameter	Symbol	Limits			Unit
		Min.	Typ.	Max.	
CLKOUT period	t_{RCP}	8.93	-	125	ns
CLKOUT "H" time	t_{RCH}	-	$0.5t_{RCP}-1.0$	-	ns
CLKOUT "L" time	t_{RCL}	-	$0.5t_{RCP}-1.0$	-	ns
LVC MOS data setup to CLKOUT	t_{RS}	$0.5t_{RCP}-1.4$	-	-	ns
LVC MOS data hold from CLKOUT	t_{RH}	$0.23t_{RCP}-1.0$	-	-	ns
LVC MOS data rise time	t_{TLH}	-	1.0	2.0	ns
LVC MOS data fall time	t_{THL}	-	1.0	2.0	ns
Input data position 0	t_{RIP1}	-0.25	0.0	+0.25	ns
Input data position 1	t_{RIP0}	$\frac{t_{RCIP}}{7}-0.25$	$\frac{t_{RCIP}}{7}$	$\frac{t_{RCIP}}{7}+0.25$	ns
Input data position 2	t_{RIP6}	$2\frac{t_{RCIP}}{7}-0.25$	$2\frac{t_{RCIP}}{7}$	$2\frac{t_{RCIP}}{7}+0.25$	ns
Input data position 3	t_{RIP5}	$3\frac{t_{RCIP}}{7}-0.25$	$3\frac{t_{RCIP}}{7}$	$3\frac{t_{RCIP}}{7}+0.25$	ns
Input data position 4	t_{RIP4}	$4\frac{t_{RCIP}}{7}-0.25$	$4\frac{t_{RCIP}}{7}$	$4\frac{t_{RCIP}}{7}+0.25$	ns
Input data position 5	t_{RIP3}	$5\frac{t_{RCIP}}{7}-0.25$	$5\frac{t_{RCIP}}{7}$	$5\frac{t_{RCIP}}{7}+0.25$	ns
Input data position 6	t_{RIP2}	$6\frac{t_{RCIP}}{7}-0.25$	$6\frac{t_{RCIP}}{7}$	$6\frac{t_{RCIP}}{7}+0.25$	ns
Phase Locked Loop set time	t_{RPLL}	-	-	10.0	ms
Clock input period	t_{RCIP}	8.93	-	125	ns

●AC Timing Diagrams

■LVC MOS

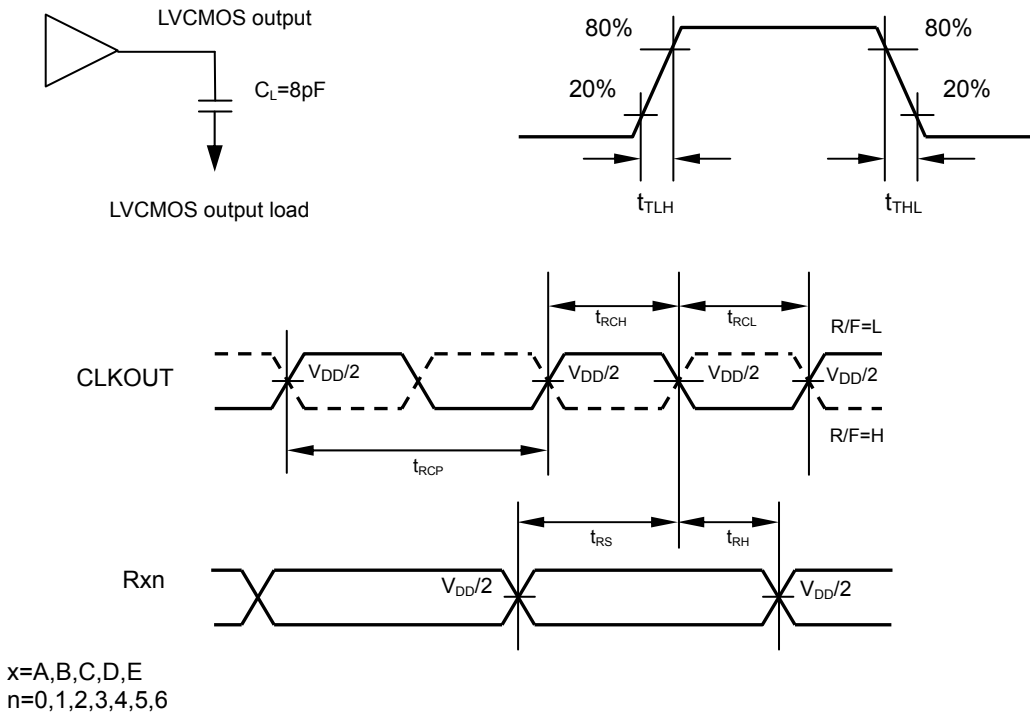

Fig.6 LVC MOS output timing

■Phase-Locked Loop set time

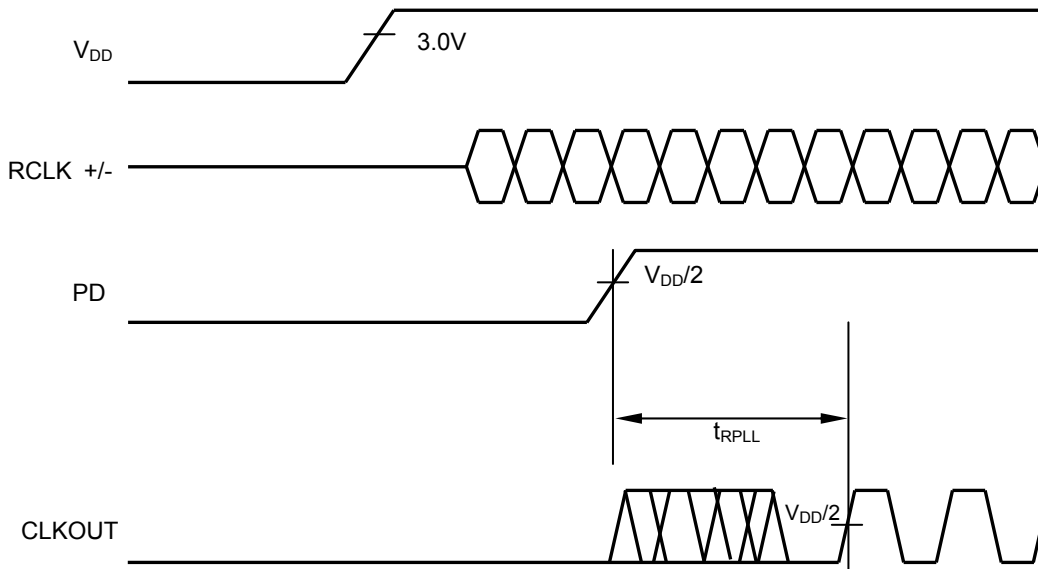

Fig.7 Phase-Locked Loop set time

●LVDS Data, Clock Input Timing

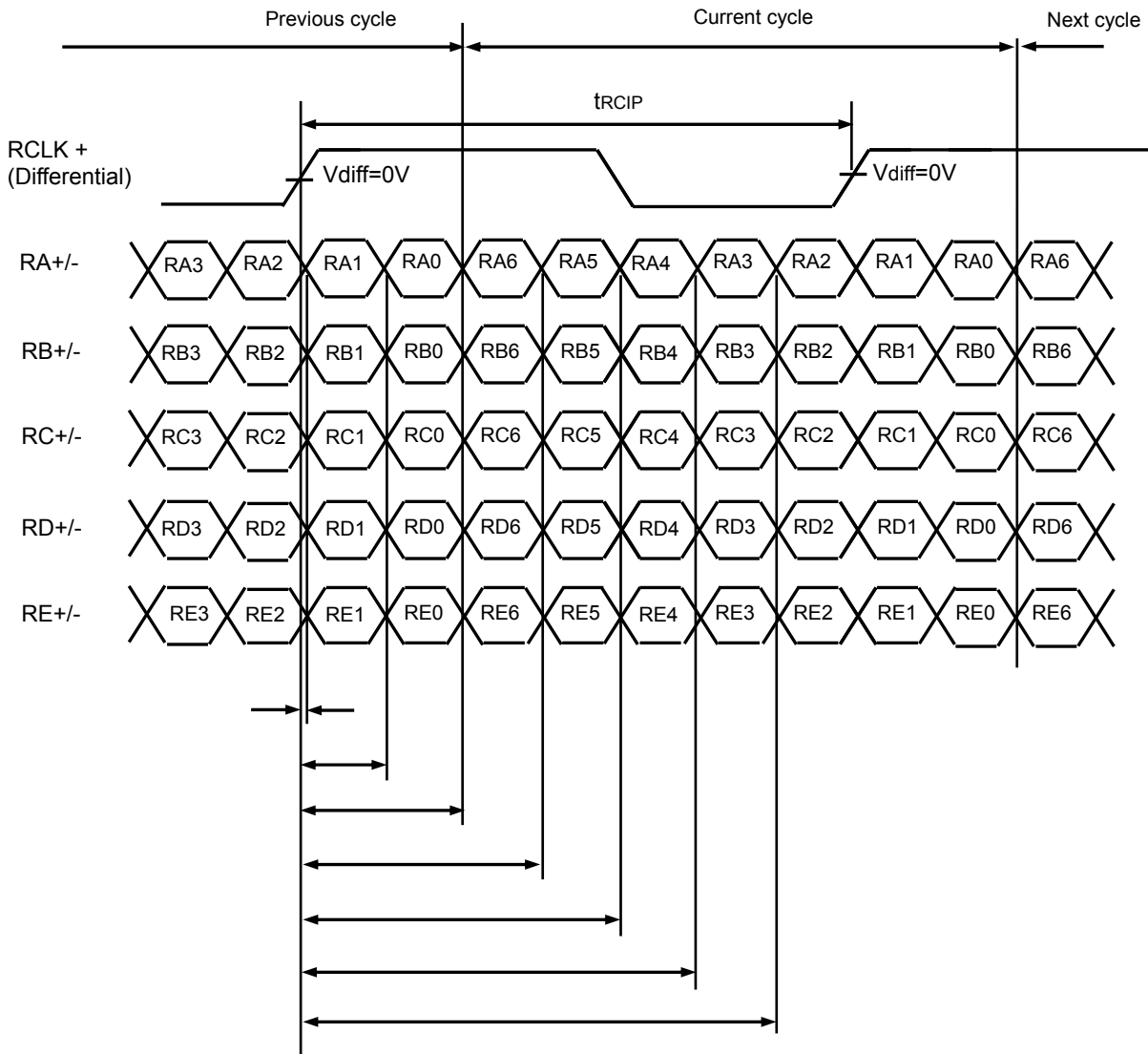

Fig.8 LVDS data and clock input timing

●LVDS Data, Clock Input and LVSMOS Output Timing

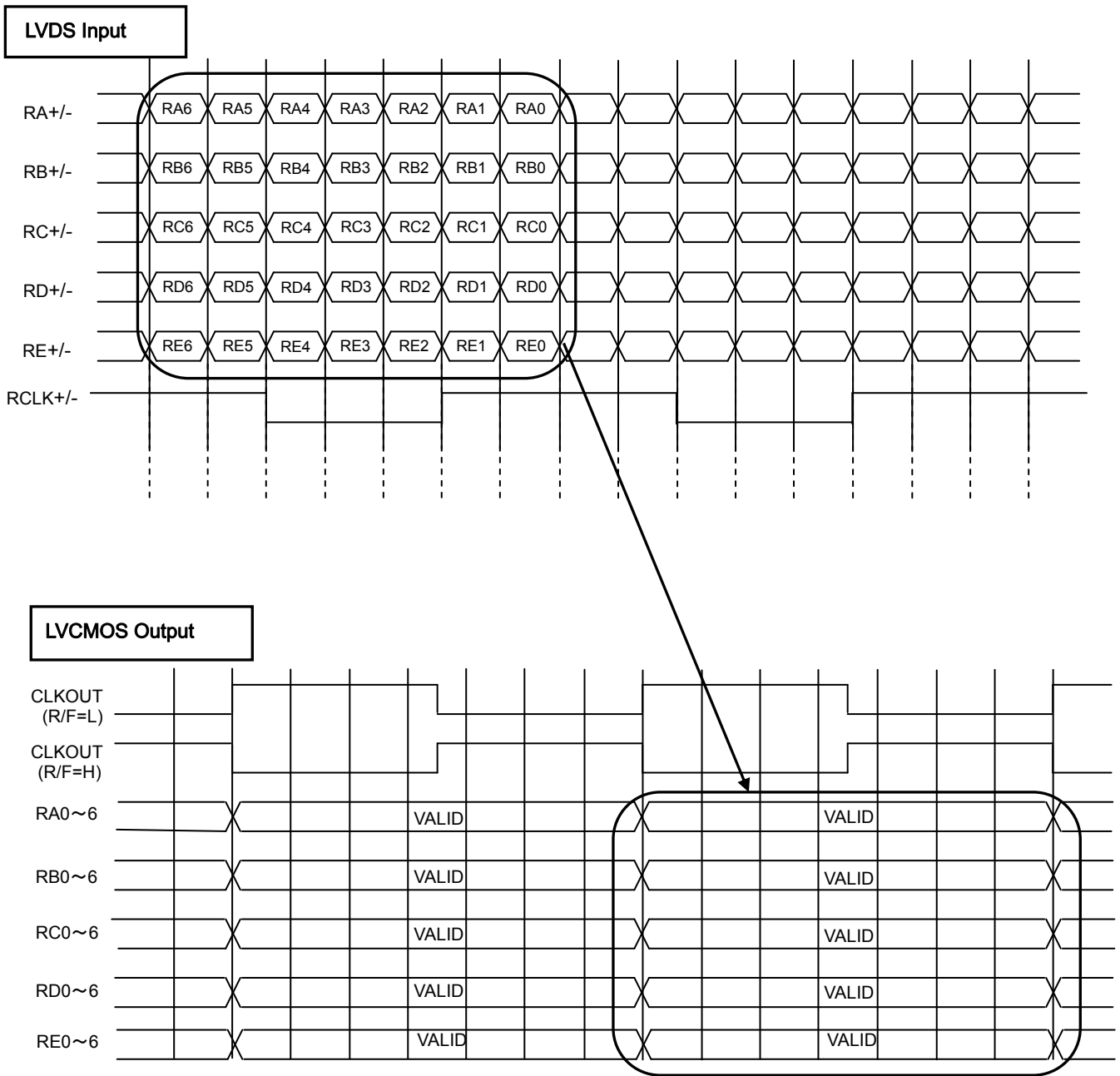

Fig.9 LVDS Data, Clock Input and LVC MOS Output Timing

●About the Power On Reset

Power on reset is not mandatory for this device.
 (The PD pin should be set to high level when power on reset procedure is not used.)

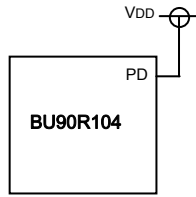
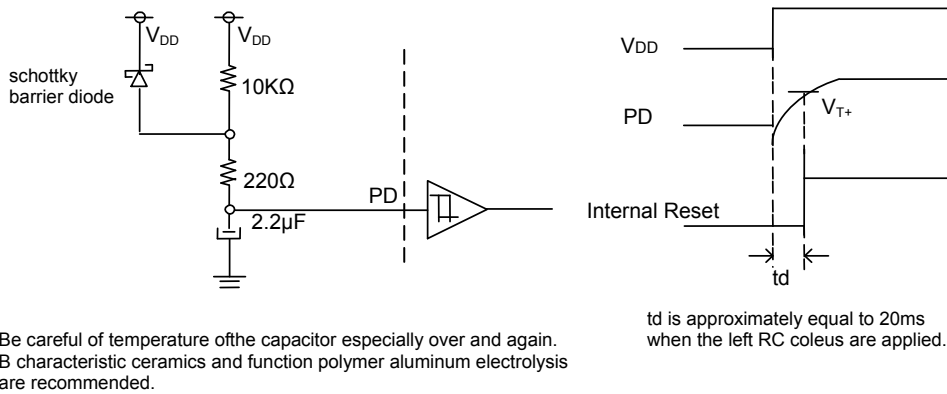

Fig.10 Terminal connection when power on reset is not used.

However, Power on reset procedure is strongly recommend for internal logic initialization by following two methods.

- ①The method of using CR circuit.
- ②The method of using external specific IC.

It is recommend to do enough examination for target application.



Be careful of temperature of the capacitor especially over and over again.
 B characteristic ceramics and function polymer aluminum electrolysis are recommended.

t_d is approximately equal to 20ms when the left RC coils are applied.

Fig.11 Power on reset by external a CR circuit

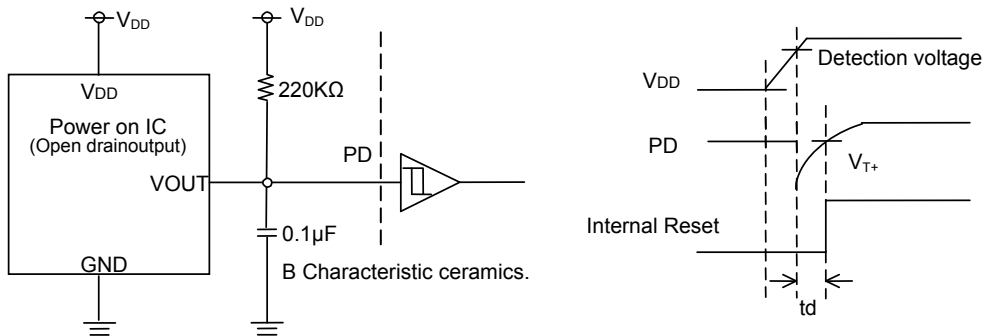
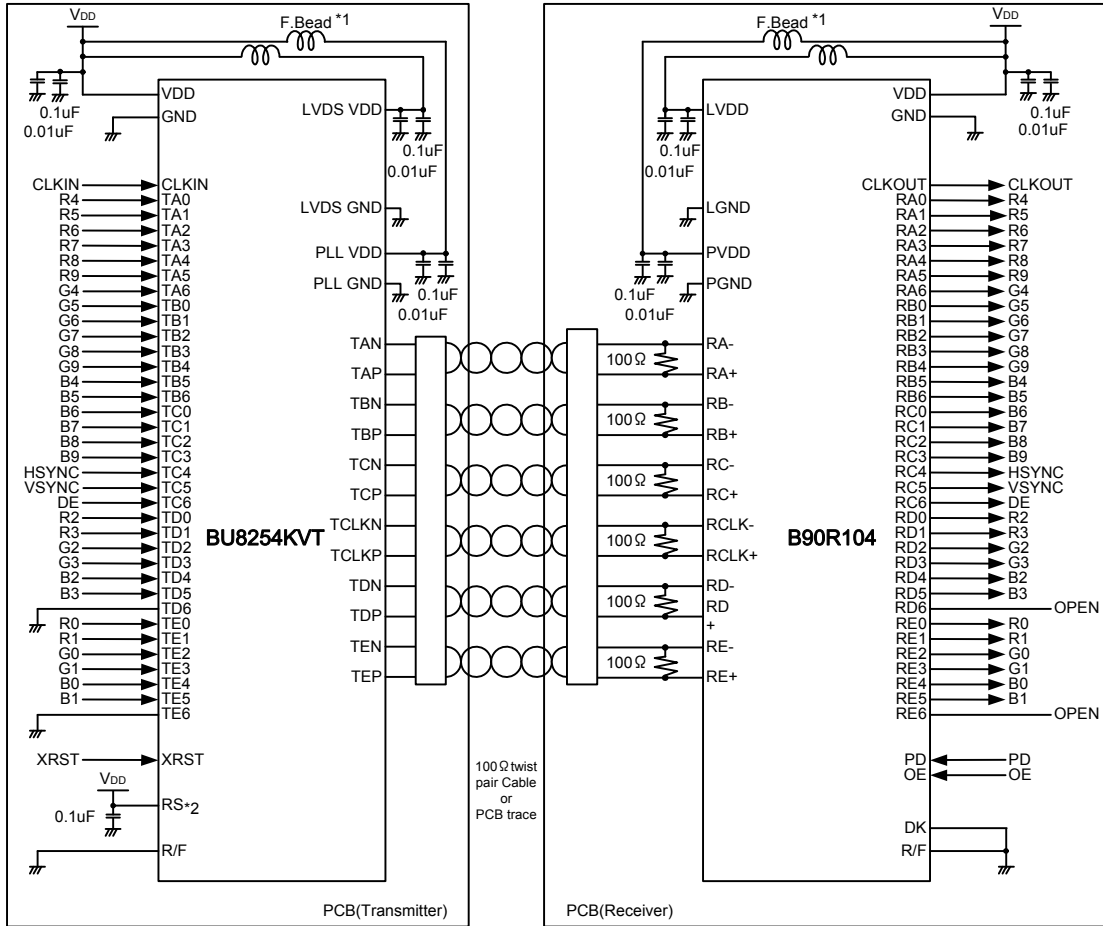

Fig.12 Power on reset by specific IC

●10 LVDS Level Input & Output

Example:

- BU8254KVT : LVCMOS level input/Falling edge/LVDS normal(350mV) swing output
- BU90R104 : LVCMOS level output/Falling edge



- *1: Recommended Parts:
F.Bead : BLM18A-Series (Murata Manufacturing Co.)
- *2 : If RS pin is tied to V_{DD}, LVDS swing is 350 mV.
If RS pin is tied to GND, LVDS swing is 200 mV.

Fig.13

●10bit Small Swing Input & LVCMOS Level Output

Example:

- BU8254KVT : LVCMOS level input/Falling edge/LVDS normal(350mV) swing output
- BU90R104 : LVCMOS level output/Falling edge

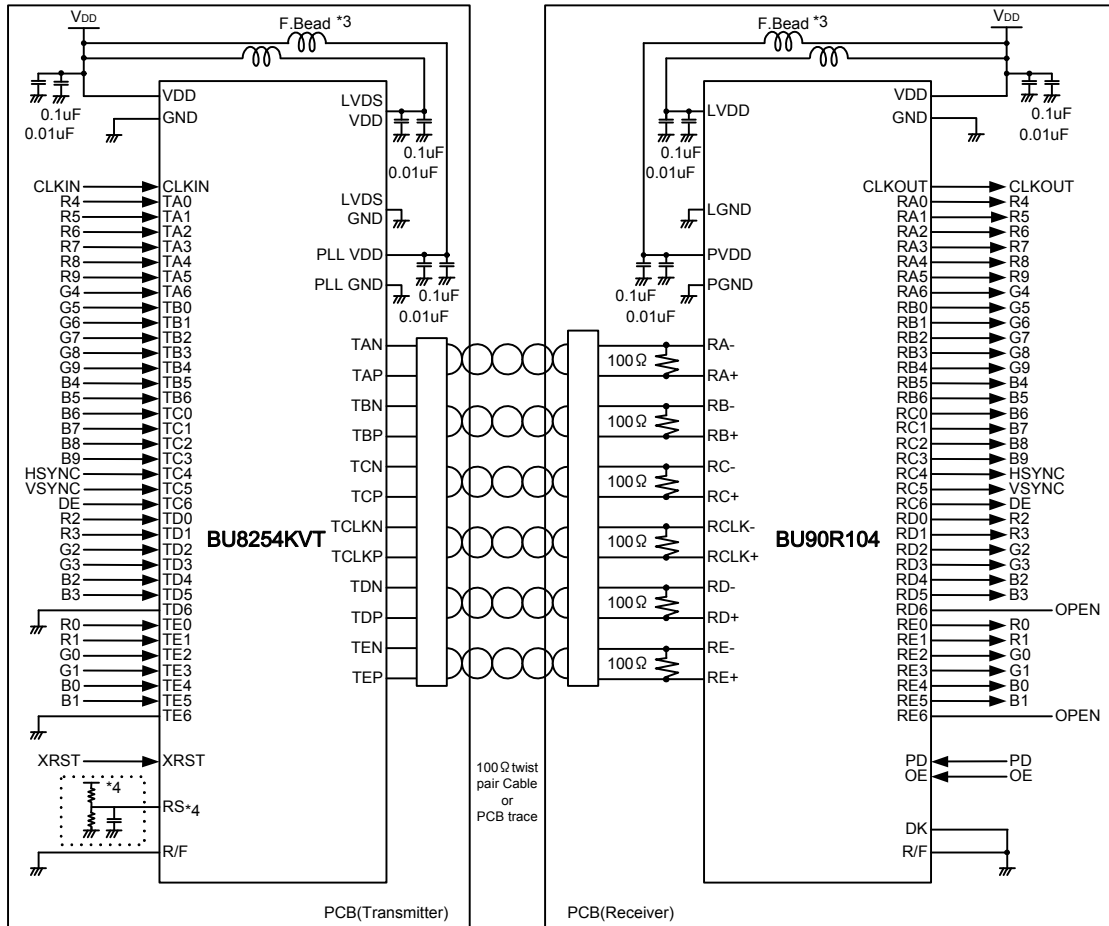

*3 Recommended Parts:

F.Bead : BLM18A-Series (Murata Manufacturing Co.)

*4 : RS pin acts as VREF input pin when input voltage is set to half of high level signal input. We recommend to locate by-pass condenser near the RS pin.

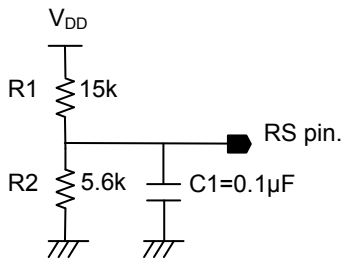

Example for LVTTTL(1.8V input):(R1,R2)=(15kΩ,5.6kΩ)

Fig.14

●Notes for use

- 1) This chip is not designed to protect from radioactivity.
- 2) The chip is made strictly for the specific application or equipment.
Then it is necessary that the unit is measured as need.
- 3) This document may be used as strategic technical data which subjects to COCOM regulations.

●Ordering part number

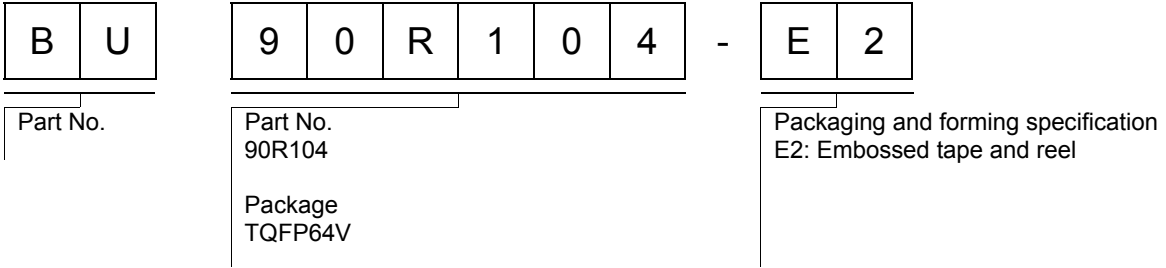

TQFP64V

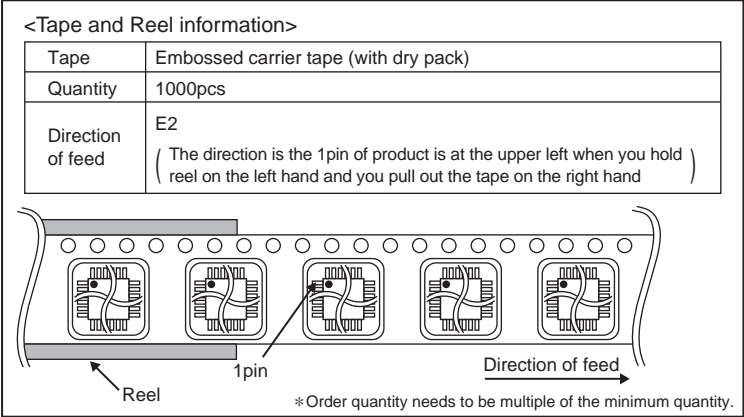
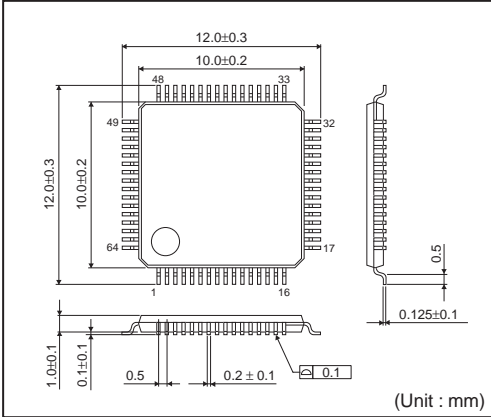

Notes

No copying or reproduction of this document, in part or in whole, is permitted without the consent of ROHM Co.,Ltd.

The content specified herein is subject to change for improvement without notice.

The content specified herein is for the purpose of introducing ROHM's products (hereinafter "Products"). If you wish to use any such Product, please be sure to refer to the specifications, which can be obtained from ROHM upon request.

Examples of application circuits, circuit constants and any other information contained herein illustrate the standard usage and operations of the Products. The peripheral conditions must be taken into account when designing circuits for mass production.

Great care was taken in ensuring the accuracy of the information specified in this document. However, should you incur any damage arising from any inaccuracy or misprint of such information, ROHM shall bear no responsibility for such damage.

The technical information specified herein is intended only to show the typical functions of and examples of application circuits for the Products. ROHM does not grant you, explicitly or implicitly, any license to use or exercise intellectual property or other rights held by ROHM and other parties. ROHM shall bear no responsibility whatsoever for any dispute arising from the use of such technical information.

The Products specified in this document are intended to be used with general-use electronic equipment or devices (such as audio visual equipment, office-automation equipment, communication devices, electronic appliances and amusement devices).

The Products specified in this document are not designed to be radiation tolerant.

While ROHM always makes efforts to enhance the quality and reliability of its Products, a Product may fail or malfunction for a variety of reasons.

Please be sure to implement in your equipment using the Products safety measures to guard against the possibility of physical injury, fire or any other damage caused in the event of the failure of any Product, such as derating, redundancy, fire control and fail-safe designs. ROHM shall bear no responsibility whatsoever for your use of any Product outside of the prescribed scope or not in accordance with the instruction manual.

The Products are not designed or manufactured to be used with any equipment, device or system which requires an extremely high level of reliability the failure or malfunction of which may result in a direct threat to human life or create a risk of human injury (such as a medical instrument, transportation equipment, aerospace machinery, nuclear-reactor controller, fuel-controller or other safety device). ROHM shall bear no responsibility in any way for use of any of the Products for the above special purposes. If a Product is intended to be used for any such special purpose, please contact a ROHM sales representative before purchasing.

If you intend to export or ship overseas any Product or technology specified herein that may be controlled under the Foreign Exchange and the Foreign Trade Law, you will be required to obtain a license or permit under the Law.



Thank you for your accessing to ROHM product informations.
More detail product informations and catalogs are available, please contact us.

ROHM Customer Support System

<http://www.rohm.com/contact/>