

Sound Processors for BOOM BOX / Mini-component Stereo



Sound Processors with Built-in 3-band Equalizers

BD3403FV, BD3861FS, BD3883FS

No.10086EAT01

●Description

The Sound Processor has a built-in 3 Band Equalizer and can be controlled with a 2-wire serial. It is suited for a sound quality design which incorporates various functions, ranging from source selectors, such as BOOM BOX, Mini-audio systems and Micro-audio systems to preamplifiers at the front stage of the power amp.

●Features

- 1) High S/N, achieved by implementing 2-stage configuration of Front Volume and Rear Volume.
- 2) Provides surround and rear volume with Soft-switch to reduce a shock sound during switching functions(BD3883FS).
- 3) Volume and tone implemented with the resistance ladder circuit (to achieve high performance with low noise and low distortion).
- 4) Uses the BiCMOS process that achieves low-consumption current, which contributes to an energy-saving design. Using the BiCMOS process, has the advantage in quality over the scaling down of the internal regulators and heat controls.
- 5) SSOP-A32 and SSOP-B40 are used for the packages. Input pins and output pins are organized and separately laid out so as to keep the signal flows in one direction which consequently, simplify pattern layout of the set board and decrease the board dimensions.

●Applications

BOOM BOX, mini-audio systems, and micro-audio systems.

●Product lineup

Parameter	BD3403FV	BD3861FS	BD3883FS
Operating Voltage Range	6.5 to 9.5V	6.5 to 9.5V	6.5 to 9.5V
Equalizer	3 band (BASS, MIDDLE, TREBLE)	3 band (BASS, MIDDLE, TREBLE)	3 band (BASS, MIDDLE, TREBLE)
Front Volume	0 to -30dB/2dB step	0 to -50dB/2dB step -50 to -70dB/4dB step, -∞dB	0 to -87dB/1dB step, -∞dB
Rear Volume	0 to -59dB/1dB step, -∞dB	0 to -59dB/1dB step, -∞dB	0, -10dB
Input Gain	0 to 26dB/2dB step	0 to 26dB/2dB step	0, 6, 12, 16, 20, 23, 26, 29dB
Microphone Input	○	○	-
Surround	○	-	○
Package	SSOP-B40	SSOP-A32	SSOP-A32

●Absolute maximum ratings (Ta=25°C)

Parameter	Symbol	Ratings		Unit
		BD3403FV	BD3861FS, BD3883FS	
Power Supply Voltage	Vcc	10	10	V
Power Dissipation	Pd	900 ^{*1}	950 ^{*2}	mW
Input Voltage Range	Vin	GND-0.3 to VCC+0.3	GND-0.3 to VCC+0.3	V
Operating Temperature Range	Topr	-25 to +75	-25 to +75	°C
Storage Temperature Range	Tstg	-55 to +125	-55 to +125	°C

^{*1} Reduced by 9.0 mW/°C over 25°C, when installed on the standard board (size: 70×70×1.6mm) for (BD3403FV).

^{*2} Reduced by 9.5 mW/°C over 25°C, when installed on the standard board (size:70×70×1.6mm) for (BD3861FS, BD3883FS).

●Operating voltage range

Parameter	Symbol	Ratings	Unit
BD3403FV	Vcc	6.5 to 9.5	V
BD3861FS			
BD3883FS			

●Electrical characteristics

◎BD3403FV

$V_{CC}=9V$, $f=1KHz$, $V_{IN}=1V_{rms}$, $R_g=600\Omega$, $R_L=10k\Omega$, $T_a=25^\circ C$, Input Gain=0dB, VOL=0dB,
Bass, Middle, Treble=0dB, Surround=OFF, unless otherwise noted.

	Parameter	Symbol	Limits			Unit	Condition
			Min.	Typ.	Max.		
TOTAL	Circuit Current	IQ	-	16.0	30.0	mA	At no signal
	Output Voltage Gain	GV	-1.5	0.0	1.5	dB	$GV=20\log(V_{OUT}/V_{IN})$
	Total Harmonic Distortion ratio	THD	-	0.02	0.08	%	400 to 30kHz BPF
	Maximum Output Voltage	VOM	2.0	2.5	-	Vrms	THD=1%
	Output Noise Voltage	VNO	-	1.8	6.0	μV_{rms}	$R_g=0k\Omega$, IHF-A
	Cross-talk between Channels	CT	-	3.0	9.0	μV_{rms}	$R_g=0k\Omega$, IHF-A
INPUT	6dBSW Gain	GV6	5	6	7	dB	$V_{IN}=200mV_{rms}$ $GV6=20\log(V_{OUT}/V_{IN})$
	Input Voltage Gain 1	Gvmax11	-1	*2	+1	dB	$V_{IN}=200mV_{rms}$, From 0 to 10dB $Gvmax11=20\log(V_{OUT}/V_{IN})$
	Input Voltage Gain 2	Gvmax12	-1.5	*2	+1.5	dB	$V_{IN}=200mV_{rms}$ From 12 to 26dB $Gvmax12=20\log(V_{OUT}/V_{IN})$
	Input Gain Switching Step	Gvmax1st	-	2	-	dB	From 0 to 26dB
	Input Total Harmonic Distortion ratio	THDI	-	0.02	0.08	%	400 to 30kHz BPF
	Input Maximum Output Voltage	VOMI	2.0	2.5	-	dB	THD=1%
	Cross-talk between Selectors	CS	-	-80.0	-70.0	dB	$R_g=0k\Omega$, IHF-A $CS=20\log(V_{OUT}/V_{IN})$
	Input Impedance	RI	35.0	50.0	65.0	k Ω	$RI=51k \times V_{OUT} / (V_{IN}-V_{OUT})$
	E Input SW Attenuation	GRE	-	-20.0	-15.0	dB	$GRE=20\log(V_{OUT}/V_{IN})$
INPUT VOLUME	Input Volume 1	GIV1	-2	*3	+2	dB	From 0 to -30dB $GIV1=20\log(V_{OUT}/V_{IN})$
	Volume Switching Step 1	GIVst1	-	2	-	dB	From 0 to -30dB
OUTPUT VOLUME	Output Volume	GOV	-1	*1	+1	dB	From 0 to -59dB $Gov=20\log(V_{OUT}/V_{IN})$
	Output Switching Step	GOVst	-	1	-	dB	From 0 to -59dB
	Maximum attenuation	GminO	-	-	-90.0	dB	IHF-A, $GminO=20\log(V_{OUT}/V_{IN})$
SURROUND	Surround Gain CH1→CH2	Gsur1	5	7	9	dB	$V_{IN}=200mV_{rms}$, $f=1kHz$
	Surround Gain CH2→CH1	Gsur2	5	7	9	dB	$V_{IN}=200V_{rms}$, $f=1kHz$
BASS	Bass Boost Gain	GBB	-2	*1	+2	dB	$V_{IN}=200mV_{rms}$, $f=90Hz$, From 0 to 14dB $GBB=20\log(V_{OUT}/V_{IN})$
	Bass Cut Gain	GBC	-2	*1	+2	dB	$V_{IN}=200mV_{rms}$, $f=90Hz$, From -14 to 0dB $GBC=20\log(V_{OUT}/V_{IN})$
	Bass Switching Step	GBST	-	2	-	dB	$V_{IN}=200mV_{rms}$, $f=90Hz$
MIDDLE	Middle Boost Gain	GMB	-2	*1	+2	dB	$V_{IN}=200mV_{rms}$, From 0 to 12dB $GMB=20\log(V_{OUT}/V_{IN})$
	Middle Cut Gain	GMC	-2	*1	+2	dB	$V_{IN}=200mV_{rms}$, From -12 to 0dB $GMC=20\log(V_{OUT}/V_{IN})$
	Middle Switching Step	GMST	-	2	-	dB	$V_{IN}=200mV_{rms}$
TREBLE	Treble Boost Gain	GTB	-2	*1	+2	dB	$V_{IN}=200mV_{rms}$, $f=10kHz$ From 0 to 12dB $GTB=20\log(V_{OUT}/V_{IN})$
	Treble Cut Gain	GTC	-2	*1	+2	dB	$V_{IN}=200mV_{rms}$, $f=10kHz$ From -12 to 0dB $GTC=20\log(V_{OUT}/V_{IN})$
	Treble Switching Step	GTST	-	2	-	dB	$V_{IN}=200mV_{rms}$, $f=10kHz$
MIC	Microphone Voltage Gain	GMIC	4.5	6.0	7.5	dB	$V_{IN}=200mV_{rms}$ $GMIC=20\log(V_{OUT}/V_{IN})$

*1 *2 Typ. is set to the value described in condition.
Min. and Max. mean the error.

ⓄBD3861FS

VCC=9V, f=1KHz, VIN=1Vrms, Rg=600Ω, RL=10kΩ, Ta=25°C, Input Gain=0dB, VOL=0dB,
Bass, Middle, Treble=0dB, unless otherwise noted.

	Parameter	Symbol	Limits			Unit	Condition
			Min.	Typ.	Max.		
TOTAL	Circuit Current	IQ	-	13.0	26.0	mA	At no signal
	Output Voltage Gain	GV	-1.5	0.0	1.5	dB	GV=20log(VOUT/VIN)
	Total Harmonic Distortion	THD	-	0.02	0.08	%	400 to 30kHz BPF
	Maximum Output Voltage	VOM	2.0	2.5	-	Vrms	THD=1%
	Output Noise Voltage	VNO	-	8.0	15.0	μVrms	Rg=0kΩ, IHF-A
	Cross-talk between Channels	CT	-	-80	-70	dB	Rg=0kΩ, IHF-A
INPUT	6dB SW Gain	GV6	5	6	7	dB	VIN=200mVrms GV6=20log(VOUT/VIN)
	Input Voltage Gain 1	Gvmax11	-1	*1	+1	dB	VIN=200mVrms From 0 to 10dB Gvmax11=20log(VOUT/VIN)
	Input Voltage Gain 2	Gvmax12	-1.5	*1	+1.5	dB	VIN=200mVrms, From 12 to 26dB Gvmax12=20log(VOUT/VIN)
	Input Gain Switching Step	Gvmax1st	-	2	-	dB	From 0 to 26dB
	Input Total Harmonic Distortion	THDI	-	0.02	0.08	%	400 to 30kHz BPF
	Input Maximum Output Voltage	VOMI	2.0	2.5	-	dB	THD=1%
	Cross-talk between Selectors	CS	-	-80.0	-70.0	dB	Rg=0kΩ, IHF-A CS=20log(VOUT/VIN)
	Input Impedance	RI	35.0	50.0	65.0	kΩ	RI=51k×VOUT/(VIN-VOUT)
INPUT VOLUME	E Input SW Attenuation	GRE	-	-20.0	-15.0	dB	GRE=20log(VOUT/VIN)
	Input Volume 1	GIV1	-2	*1	+2	dB	From 0 to -50dB GIV1=20log(VOUT/VIN)
	Input Volume 2	GIV2	-3	*1	+3	dB	From -54 to -70dB GIV2=20log(VOUT/VIN)
	Volume Switching Step 1	GIVst1	-	2	-	dB	From 0 to -50dB
	Volume Switching Step 2	GIVst2	-	4	-	dB	From -54 to -70dB
OUTPUT VOLUME	Maximum attenuation	GminI	-	-	-90.0	dB	IHF-A, GminI=20log(VOUT/VIN)
	Output Volume	GOV	-1	*1	+1	dB	From 0 to -59dB Gov=20log(VOUT/VIN)
	Output Switching Step	GOVst	-	1	-	dB	From 0 to -59dB
BASS	Maximum attenuation	GminO	-	-	-90.0	dB	IHF-A GminO=20log(VOUT/VIN)
	Bass Boost Gain	GBB	-2	*1	+2	dB	VIN=200mVrms, f=90Hz, From 0 to 14dB GBB=20log(VOUT/VIN)
	Bass Cut Gain	GBC	-2	*1	+2	dB	VIN=200mVrms, f=90Hz, From -14 to 0dB GBC=20log(VOUT/VIN)
MIDDLE	Bass Switching Step	GBST	-	2	-	dB	VIN=200mVrms, f=90Hz
	Middle Boost Gain	GMB	-2	*1	+2	dB	VIN=200mVrms, From 0 to 12dB GMB=20log(VOUT/VIN)
	Middle Cut Gain	GMC	-2	*1	+2	dB	VIN=200mVrms, From -12 to 0dB GMC=20log(VOUT/VIN)
TREBLE	Middle Switching Step	GMST	-	2	-	dB	VIN=200mVrms
	Treble Boost Gain	GTB	-2	*1	+2	dB	VIN=200mVrms, f=10kHz From 0 to 12dB GTB=20log(VOUT/VIN)
	Treble Cut Gain	GTC	-2	*1	+2	dB	VIN=200mVrms, f=10kHz From -12 to 0dB GTC=20log(VOUT/VIN)
MIC	Treble Switching Step	GTST	-	2	-	dB	VIN=200mVrms, f=10kHz
	Microphone Voltage Gain	GMIC	4.5	6.0	7.5	dB	VIN=200mVrms GMIC=20log(VOUT/VIN)

*1 Typ. is set to the value described in condition.
Min. and Max. mean the error.

ⓄBD3883FS

Ta=25°C, VCC=8V, f=1kHz, Vi=200mVrms, RL=10kΩ, Rg=600Ω,

Input Selector=Ach, Input Gain=0dB, Volume=0dB, Bass=0dB, Middle=0dB, Treble=0dB,

Surround=OFF, RECOUT=OFF, unless otherwise noted.

	Parameter	Symbol	Limits			Unit	Condition
			Min.	Typ.	Max.		
TOTAL	Circuit Current	IQ	-	8	21	mA	At no signal
	Total Output Voltage Gain	Gv	-2	0	2	dB	
	Total Harmonic Distortion	THDO	-	0.01	0.1	%	BW=400 to 30kHz
	Maximum Output Voltage	Vomaxo	1.6	2.1	-	Vrms	THD=1% BW=400 to 30kHz
	Total Residual Noise Voltage	Vno	-	2	10	μVrms	Rg=0Ω, Vol=-∞dB BW=IHF-A, REAR ATT=-10dB
	Total Output Noise Voltage	Vmno	-	4	15	μVrms	Rg=0Ω, Vol=0dB BW=IHF-A
	Cross-talk between Channels	CTC12	-	-80	-70	dB	Rg=0Ω, BW=IHF-A VOUT=1Vrms
	Input Impedance	Rin	70	100	130	kΩ	
	Output Impedance	Rout	-	-	50	Ω	
INPUT	Cross-talk between Selectors	CTS1	-	-80	-70	dB	VOUT=1Vrms Rg=0Ω, BW=IHF-A
VOLUME	Volume Control Range	VRI	-90	-87	-84	dB	BW=IHF-A, Vout=1Vrms
	Volume Setting Error 1	VEI1	-2	0	2	dB	0 to -53dB, BW=IHF-A VOUT=1Vrms
	Volume Setting Error 2	VEI2	-3	0	3	dB	-54 to -87dB, BW=IHF-A VOUT=1Vrms
	Maximum Attenuation	Vmin	-	-	-90	dB	BW=IHF-A VOUT=1Vrms
	Volume Input Impedance	Rvin	39	56	73	kΩ	
BASS	Bass Gain	Gb	-17.5 to +17.5			dB	
	Bass Gain Setting Error	BE	-2.5	0	-2.5	dB	
MIDDLE	Middle Gain	Gm	-14 to +14			dB	
	Middle Gain Setting Error	ME	-2	0	-2	dB	
TREBLE	Treble Gain	Gt	-14 to +14			dB	
	Treble Gain Setting Error	TE	-2	0	2	dB	
SURROUND	Surround In-phase Gain	Vsur1	-2	0	2	dB	
	Surround Single-phase Gain	Vsur2	4.3	6.3	8.3	dB	AC-grounding
	Opposite-phase Gain	Vsur3	8	10	12	dB	

• This IC is not designed to be radiation-resistant.

●Control signal specifications

1. Signal Timing Conditions

- Data is read on the rising edge of the clock.
- Latch is read on the falling edge of the clock.
- Latch signal must terminate with the LOW state.
- To avoid malfunctions, clock and data signals must terminate with the LOW state.

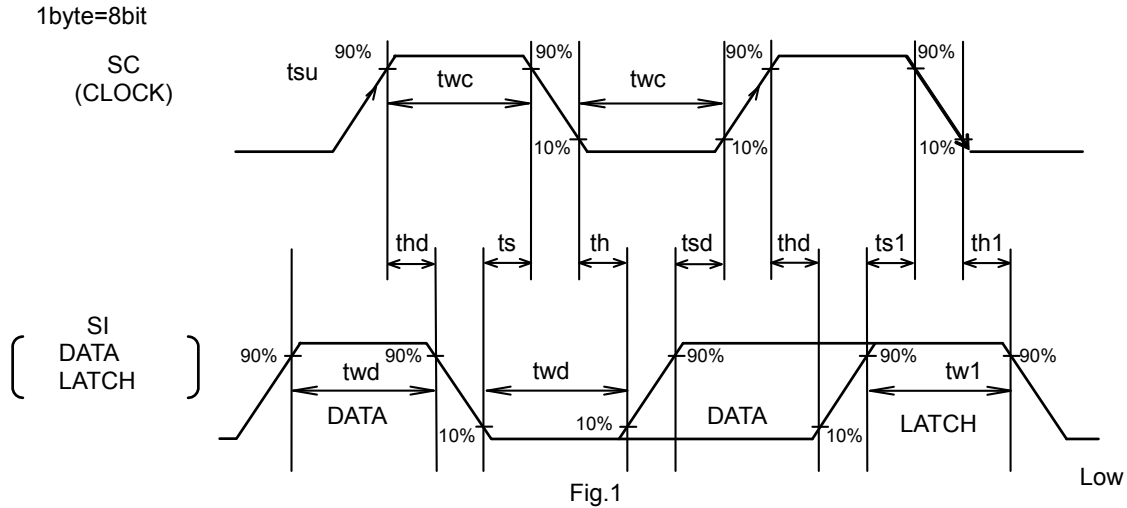

Parameter	Symbol	Limits			Unit
		Min.	Typ.	Max.	
Minimum Clock Width	twc	2.0	-	-	μs
Minimum Data Width	twd	2.0	-	-	μs
Minimum Latch Width	tw1	2.0	-	-	μs
Data Set-up Time (DATA→CLK)	Tsd	1.0	-	-	μs
Data Hold Time (CLK→DATA)	Thd	1.0	-	-	μs
Latch Set-up Time (CLK→LATCH)	ts1	1.0	-	-	μs
Latch Hold Time (DATA→LATCH)	th1	1.0	-	-	μs
Latch Low Set-up Time	ts	1.0	-	-	μs
Latch Low Hold Time	th	1.0	-	-	μs

2. Voltage Conditions for Control Signals (BD3403FV, BD3861FS)

Parameter	Condition	Limits			Unit
		Min.	Typ.	Max.	
“H” Input Voltage	Vcc=6.5 to 9.5V	2.6	-	5.5	V
“L” Input Voltage	Vcc=6.5 to 9.5V	0	-	1.1	V

3. Voltage Conditions for Control Signals (BD3883FS)

Parameter	Condition	Limits			Unit
		Min.	Typ.	Max.	
“H” Input Voltage	Vcc=6.5 to 9.5V	2.2	-	5.5	V
“L” Input Voltage	Vcc=6.5 to 9.5V	0	-	1.0	V

●Control data format list

(BD3403FV)

Address 1

D10	D11	D12	D13	D14	D15	D16	D17
OUTPUT Volume 1		OUTPUT Volume 2				Function Select 0 0	

Address 2

D20	D21	D22	D23	D24	D25	D26	D27
INPUT Volume				Surround 0:OFF 1:ON	Function Select 0 1 0		

Address 3

D30	D31	D32	D33	D34	D35	D36	D37
Input Selector			6dB SW 0: 0dB 1:+6dB	IN E MUTE 0:OFF 1:ON	Function Select 0 0 1		

Address 4

D40	D41	D42	D43	D44	D45	D46	D47
Input Gain/Bass				0: Input Gain 1: Bass	Function Select 1 0 1		

Address 5

D50	D51	D52	D53	D54	D55	D56	D57
Middle/Treble				0: Middle 1: Treble	Function Select 0 1 1		

(BD3861FS)

Address 1

D10	D11	D12	D13	D14	D15	D16	D17
OUTPUT Volume		OUTPUT Volume 2				Function Select 0 0	

Address 2

D20	D21	D22	D23	D24	D25	D26	D27
INPUT Volume					Function Select 0 1 0		

Address 3

D30	D31	D32	D33	D34	D35	D36	D37
Input Selector			6dBSW 0: 0dB 1:+6dB	IN E MUTE 0:OFF 1:ON	Function Select 0 0 1		

Address 4

D40	D41	D42	D43	D44	D45	D46	D47
Input Gain/Bass				0: Input Gain 1: Bass	Function Select 1 0 1		

Address 5

D50	D51	D52	D53	D54	D55	D56	D57
Middle/Treble				0: Middle 1: Treble	Function Select 0 1 1		

(BD3883FS)

- Basic Configuration of Control Data Format

← Data input direction

	MSB									LSB
	D9	D8	D7	D6	D5	D4	D3	D2	D1	D0
Data	Data								Select Address	

- Control Data Formats

← Data input direction

									Select Address	
	D9	D8	D7	D6	D5	D4	D3	D2	D1	D0
Data(1)	Input Gain			Input Selector			Treble fc		0	0
Data(2)	Front Volume A					Front Volume B		*	0	1
Data(3)	Bass Gain				Treble Gain				1	0
Data(4)	Middle Gain				Time Constant Select	REC OUT	Surround	Rear Volume	1	1

O* indicates 0 or 1.

- By changing the setting of Select Address, four different control formats are selectable. (BD3883FS)
- At power-on sequence, initialize all data.

Example:

← Data input direction

MSB	LSB	MSB	LSB	MSB	LSB	MSB	LSB
Data(1)	L	Data(2)	L	Data(3)	L	Data(4)	L

"L" means a "latch."

- After power-on, for the second and subsequent times, only the necessary data can be selected for setting.

Example: When changing the volume:

← Data input direction

MSB	LSB
Data(2)	L

"L" means a "latch."

- RECOUT, Surround and Rear Volume in Data(4) are Soft-switched using time constants. (BD3883FS)

●Block diagram, application circuit, pin assignment

(BD3403FV)

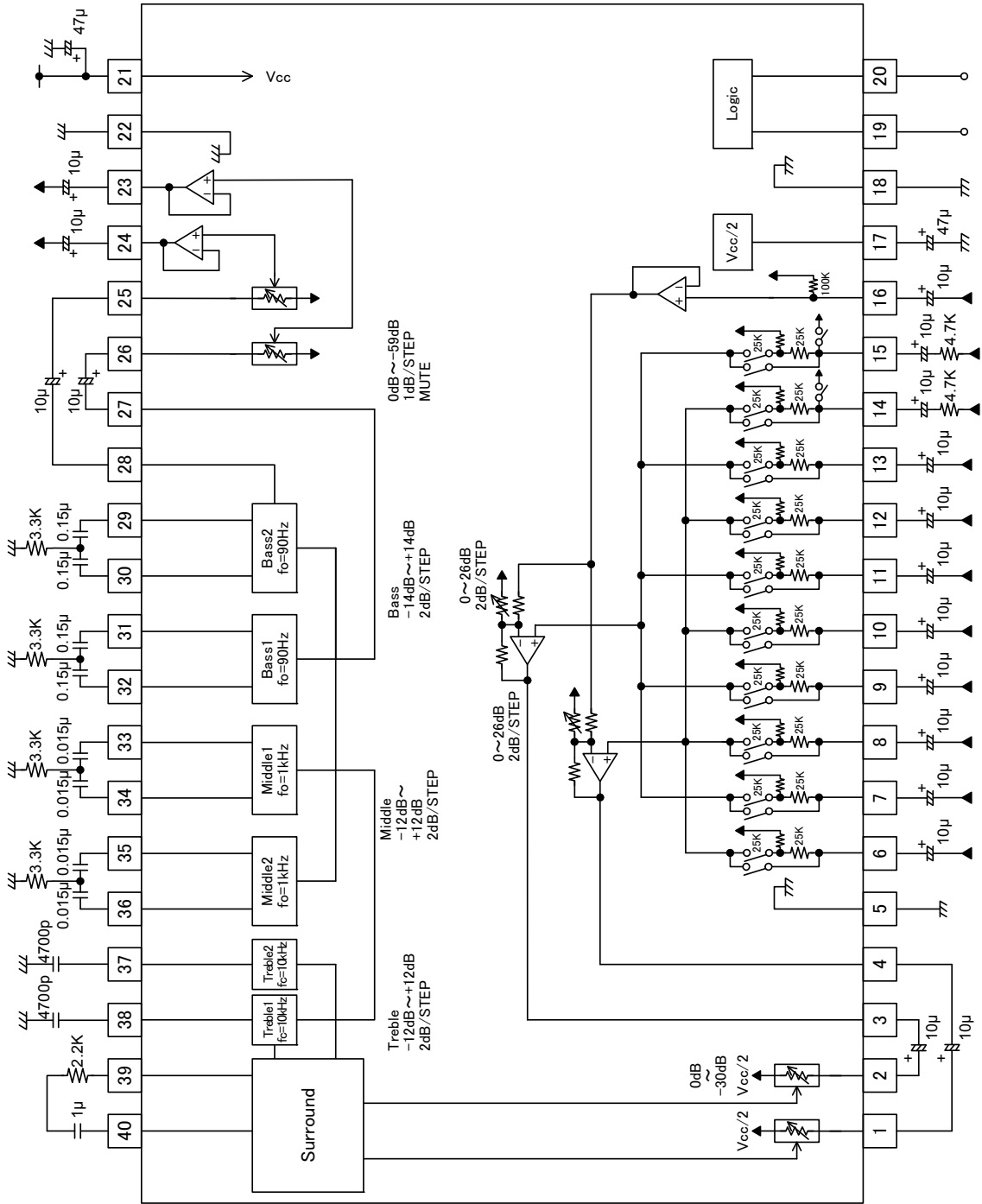

UNIT RESISTANCE : Ω
CAPACITANCE : F

Fig.2

(BD3861FS)

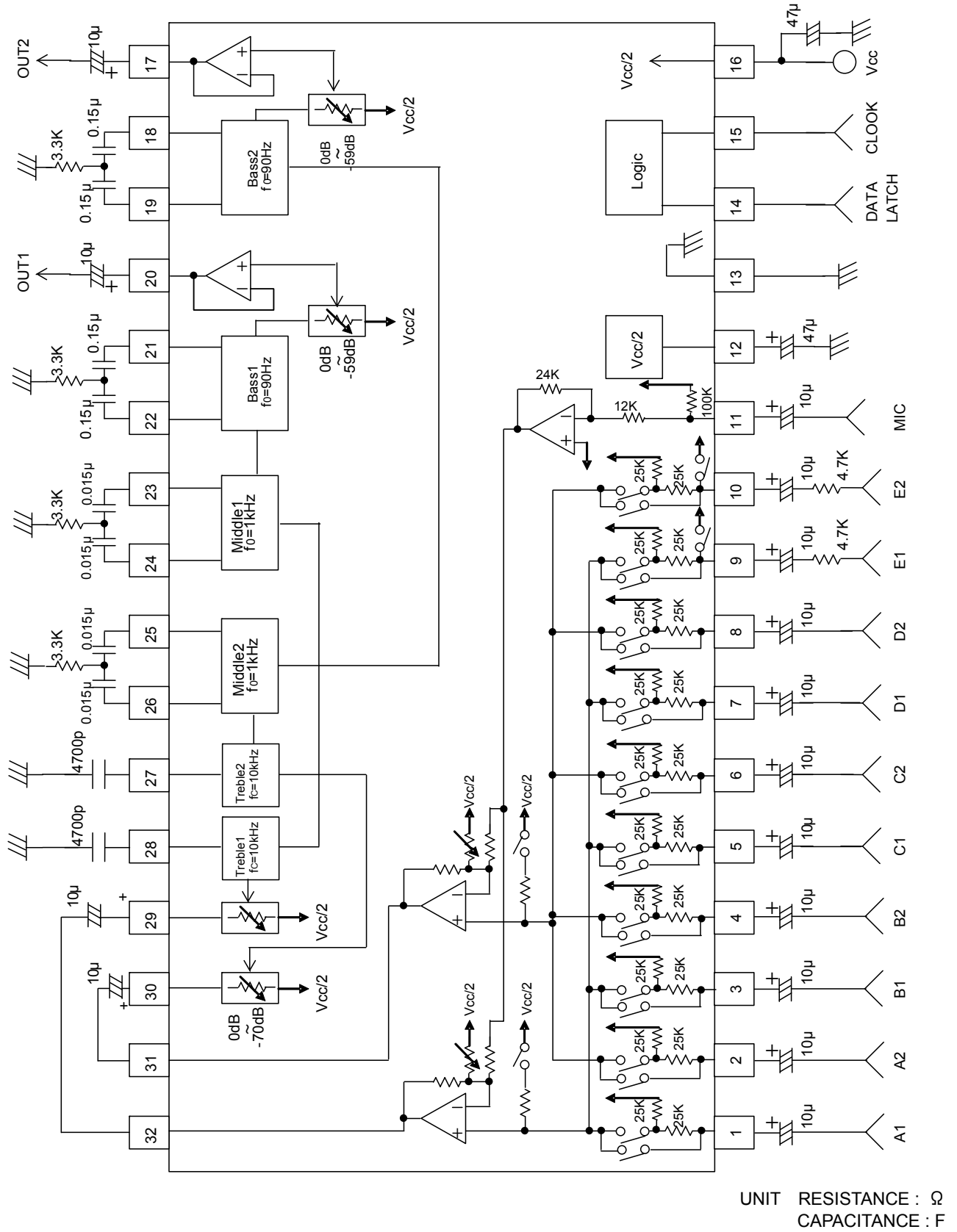

Fig.3

UNIT RESISTANCE : Ω
CAPACITANCE : F

(BD3883FS)
When using RECOUT:

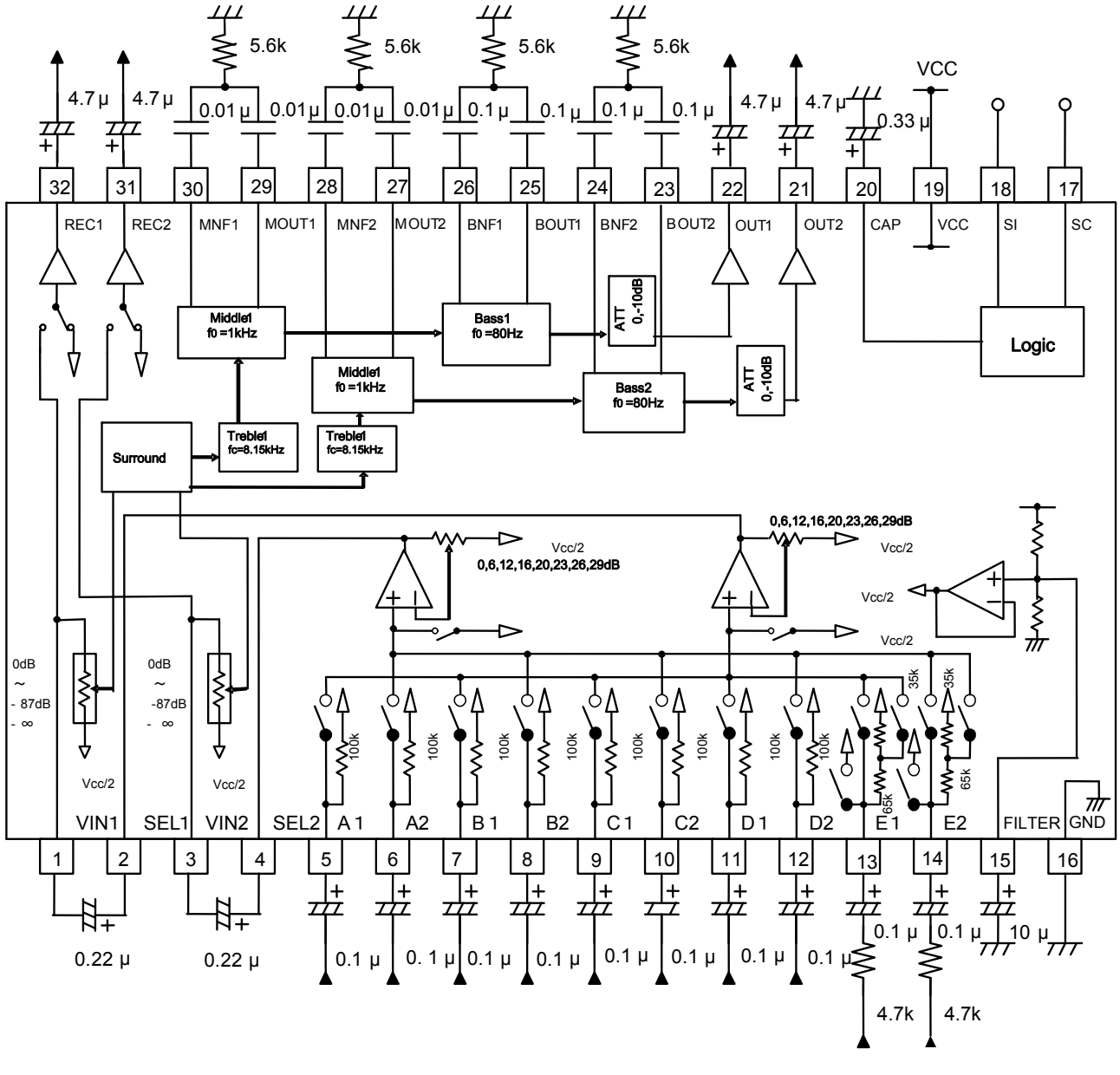

Fig.4

UNIT
RESISTANCE: Ω
CAPACITOR: F

●Reference data

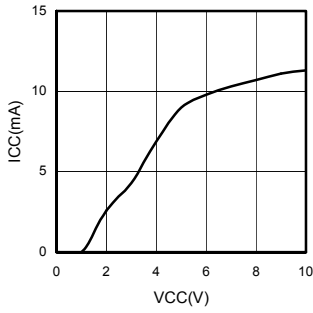

Fig.6 Circuit Current – Supply Voltage (BD3403FV)

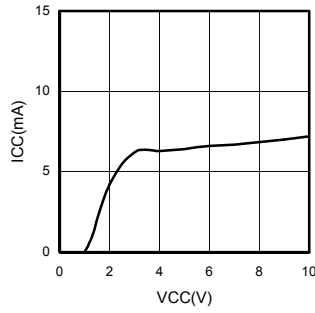

Fig.7 Circuit Current – Supply Voltage (BD3883FS)

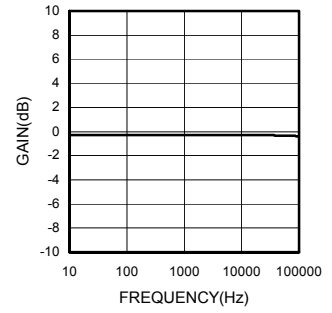

Fig.8 Voltage Gain - Frequency

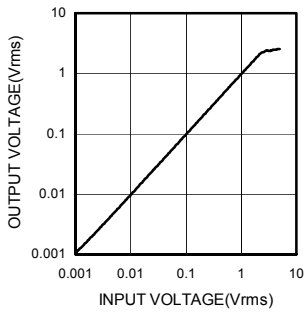

Fig.9 Output Voltage - Input Voltage

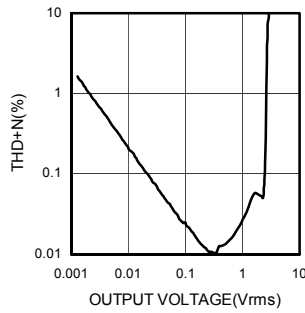

Fig.10 Total Harmonic Distortion ratio - Output Voltage (BD3403FV, BD3861FS)

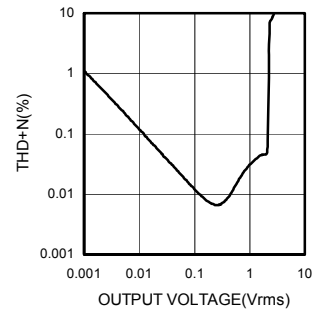

Fig.11 Total Harmonic Distortion ratio - Output Voltage (BD3883FS)

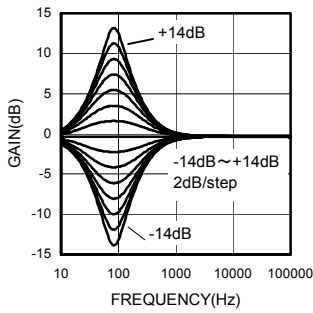

Fig.12 Bass Gain - Frequency (BD3403FV, BD3861FS)

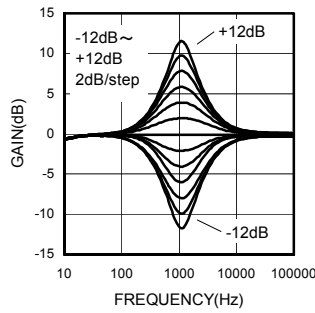

Fig.13 Middle Gain - Frequency (BD3403FV, BD3861FS)

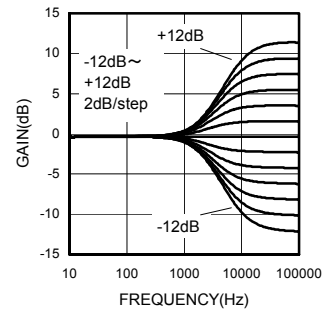

Fig.14 Treble Gain - Frequency (BD3403FV, BD3861FS)

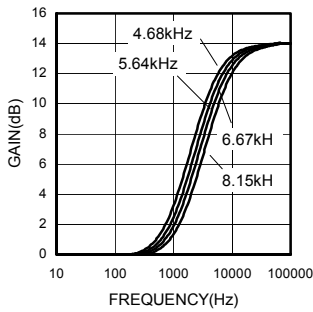

Fig.15 Variable Treble Cut-off Frequency (BD3883FS)

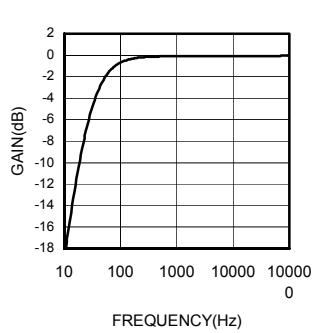

Fig.16 2ndHPF - Frequency (BD3883FS)

●Notes for use

- 1) Numbers and data in entries are representative design values and are not guaranteed values of the items.
- 2) Although ROHM is confident that the example application circuit reflects the best possible recommendations, be sure to verify circuit characteristics for your particular application. Modification of constants for other externally connected circuits may cause variations in both static and transient characteristics for external components as well as this Rohm IC. Allow for sufficient margins when determining circuit constants.
- 3) Absolute maximum ratings
Use of the IC in excess of absolute maximum ratings, such as the applied voltage or operating temperature range (Topr), may result in IC damage. Assumptions should not be made regarding the state of the IC (short mode or open mode) when such damage is suffered. A physical safety measure, such as a fuse, should be implemented when using the IC at times where the absolute maximum ratings may be exceeded.
- 4) GND potential
Ensure a minimum GND pin potential in all operating conditions. Make sure that no pins are at a voltage below the GND at any time, regardless of whether it is a transient signal or not.
- 5) Thermal design
Perform thermal design, in which there are adequate margins, by taking into account the permissible dissipation (Pd) in actual states of use.
- 6) Short circuit between terminals and erroneous mounting
Pay attention to the assembly direction of the ICs. Wrong mounting direction or shorts between terminals, GND, or other components on the circuits, can damage the IC.
- 7) Operation in strong electromagnetic field
Using the ICs in a strong electromagnetic field can cause operation malfunction.
- 8) 2-wire serial control
Because SC and SI terminals are designed for inputting high-frequency digital signals, wiring and layout patterns should be routed as not to cause interference with the analog-signal-related lines.
- 9) E Input external resistance (BD3883FS)
To avoid a sudden noise into E Input, external resistance (4.7kΩ) should be connected as close as possible to the IC terminal.
- 10) Function switching
Action to absorb shock sounds is taken when switching between the Volume, Treble, Middle and Bass functions.
- 11) Power-ON Reset (BD3883FS)
A built-in circuit for performing initialization inside the IC at Power-ON is provided. Specifically, the initial states are set as described in the table below. In the case of the setting design, however, to be on the safe side, it is recommended that data shall be sent to all the addresses as initial data at power-ON and, until this sending operation is completed, MUTE shall be applied. To avoid malfunctions, serial data signals must be set to the Low state at power-ON/OFF.

Function	Initial State
Input Selector	MUTE
Input Gain	0 dB
RECOU	OFF
Volume	-∞dB
Surround	OFF
Treble	0 dB
Middle	0 dB
Bass	0 dB
Rear Volume	0dB

- 12) Step switching noise (BD3883FS)
For Surround and Rear Volume, an external capacitor C is attached to the CAP pin to control the switching step noise. In the application circuit, a constant value, as an example, is shown by the CAP pin.
The time constant for charge/discharge of the capacitor C (varying between VBE to 5VBE (2.65V)) controls the slow switching operation.
The switching time constant T is calculated as the follows:

$$T=2.55 \times 10^5 \times C$$
VBE has temperature characteristics and may affect the value of the time constant T.

13) Input Selector and Input Gain

When changing Input Selector or Input Gain, the Soft-switching is not applied. Therefore, it is recommended to implement the MUTE function.

⊙MUTE setting example

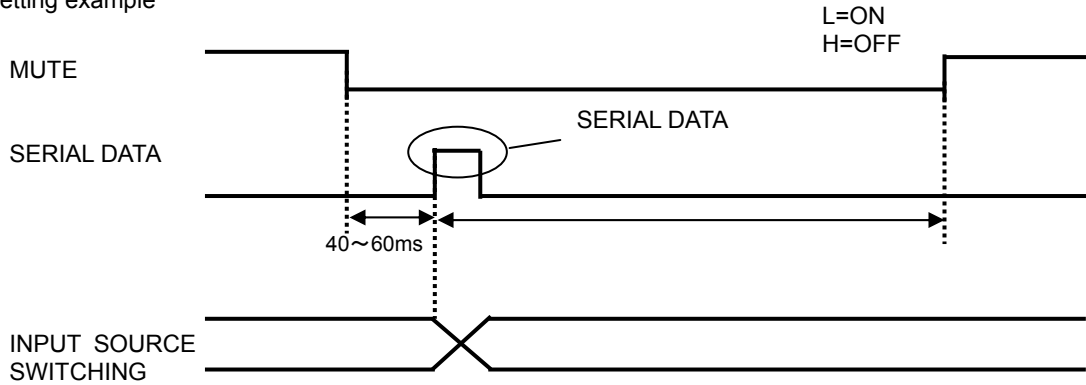

Fig.17

14) Constraints of serial control (BD3883FS)

On Soft-switching of the RECOUT, Surround, and Rear Volume functions, data must not be sent serially to the functions before the switching operation is completed.

If the function for Soft-switch should serially send the data (Data(4)) on the same Select Address, the time interval between the send operations must be set to 500 -600msec.

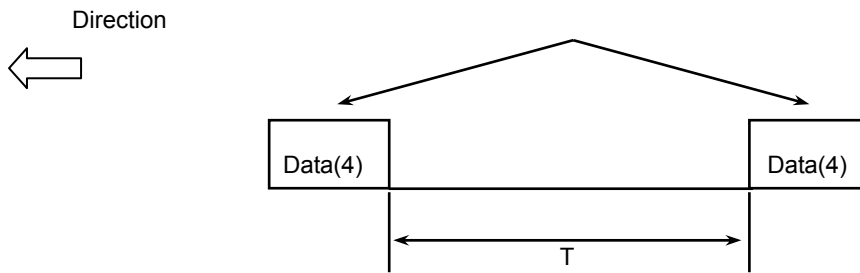

Fig.18

15) Function setting while muting Volume (BD3883FS)

While muting Volume, to avoid increasing residual noise, set Bass, Middle and Treble to 0dB, Surround to OFF, and Rear Volume to -10dB.

● Ordering part number

B	D
---	---

Part No.

3	4	0	3
---	---	---	---

Part No.
3403
3861, 3883

F	V
---	---

Package
FV: SSOP-B40
FS: SSOP-A32

E	2
---	---

Packaging and forming specification
E2: Embossed tape and reel

SSOP-B40

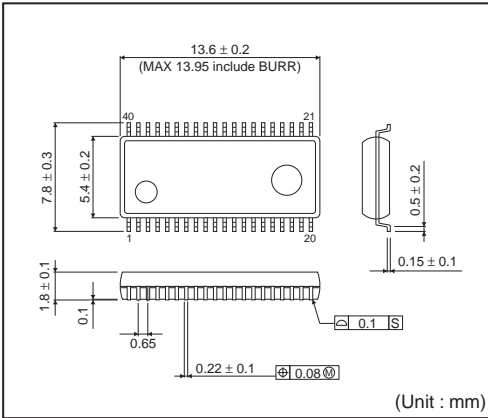

<Tape and Reel information>

Tape	Embossed carrier tape
Quantity	2000pcs
Direction of feed	E2 (The direction is the 1pin of product is at the upper left when you hold reel on the left hand and you pull out the tape on the right hand)

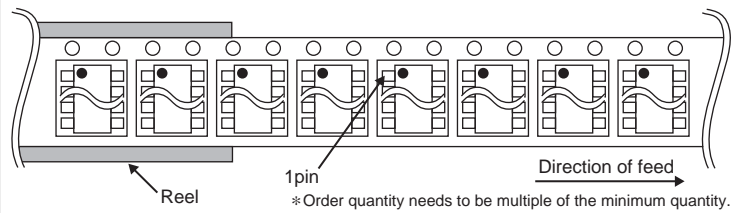

SSOP-A32

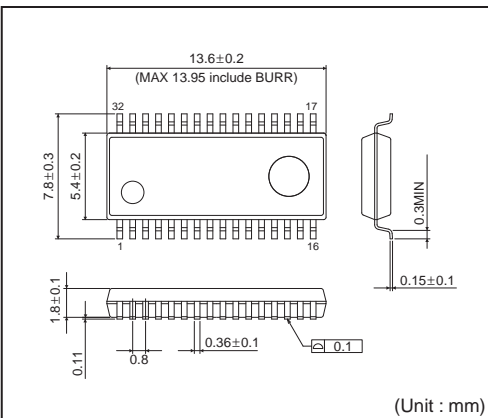

<Tape and Reel information>

Tape	Embossed carrier tape
Quantity	2000pcs
Direction of feed	E2 (The direction is the 1pin of product is at the upper left when you hold reel on the left hand and you pull out the tape on the right hand)

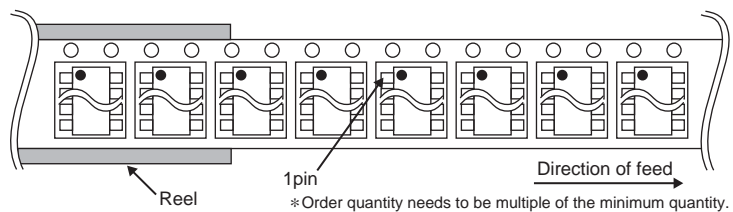

Notes

No copying or reproduction of this document, in part or in whole, is permitted without the consent of ROHM Co.,Ltd.

The content specified herein is subject to change for improvement without notice.

The content specified herein is for the purpose of introducing ROHM's products (hereinafter "Products"). If you wish to use any such Product, please be sure to refer to the specifications, which can be obtained from ROHM upon request.

Examples of application circuits, circuit constants and any other information contained herein illustrate the standard usage and operations of the Products. The peripheral conditions must be taken into account when designing circuits for mass production.

Great care was taken in ensuring the accuracy of the information specified in this document. However, should you incur any damage arising from any inaccuracy or misprint of such information, ROHM shall bear no responsibility for such damage.

The technical information specified herein is intended only to show the typical functions of and examples of application circuits for the Products. ROHM does not grant you, explicitly or implicitly, any license to use or exercise intellectual property or other rights held by ROHM and other parties. ROHM shall bear no responsibility whatsoever for any dispute arising from the use of such technical information.

The Products specified in this document are intended to be used with general-use electronic equipment or devices (such as audio visual equipment, office-automation equipment, communication devices, electronic appliances and amusement devices).

The Products specified in this document are not designed to be radiation tolerant.

While ROHM always makes efforts to enhance the quality and reliability of its Products, a Product may fail or malfunction for a variety of reasons.

Please be sure to implement in your equipment using the Products safety measures to guard against the possibility of physical injury, fire or any other damage caused in the event of the failure of any Product, such as derating, redundancy, fire control and fail-safe designs. ROHM shall bear no responsibility whatsoever for your use of any Product outside of the prescribed scope or not in accordance with the instruction manual.

The Products are not designed or manufactured to be used with any equipment, device or system which requires an extremely high level of reliability the failure or malfunction of which may result in a direct threat to human life or create a risk of human injury (such as a medical instrument, transportation equipment, aerospace machinery, nuclear-reactor controller, fuel-controller or other safety device). ROHM shall bear no responsibility in any way for use of any of the Products for the above special purposes. If a Product is intended to be used for any such special purpose, please contact a ROHM sales representative before purchasing.

If you intend to export or ship overseas any Product or technology specified herein that may be controlled under the Foreign Exchange and the Foreign Trade Law, you will be required to obtain a license or permit under the Law.



Thank you for your accessing to ROHM product informations.
More detail product informations and catalogs are available, please contact us.

ROHM Customer Support System

<http://www.rohm.com/contact/>