

GPIO ICs Series

GPIO Expander IC



BU8272GUW

No.09098EAT01

●Description

GPIO expander is useful especially for the application that is in short of IO ports.

It can

1. Control GPIO output states by I²C write protocol.
2. Know GPIO input states by I²C read protocol.

Furthermore, it has the interrupt function that can release CPU from polling the registers in the GPIO expander. GPIO expander are also equipped with Built-in power on reset, 3V tolerant input, and NMOS open-drain output.

●Features

- 1) 400Kbps, 2-Wire serial interface
- 2) Interrupt output
- 3) 20-bit General purpose input/output interface
8-bit and 12-bit IO groups are designed for different power supply voltages from the device core voltage supply

● Absolute Maximum Ratings

(Ta=25°C)

Item	Symbol	Value	Unit	comment
Supply Voltage	VDD	-0.3 ~ +2.5	V	-
	VDDI2C	-0.3 ~ +3.5	V	-
	VDDIO	-0.3 ~ +3.5	V	-
Input voltage	VI	-0.3 ~ VDD +0.5 ^{*1}	V	CMOS Core
		-0.3 ~ VDDI2C +0.5 ^{*1}	V	CMOS I/O for 2-Wire
		-0.3 ~ VDDIO +0.5 ^{*1}	V	CMOS I/O
Storage temperature range	Tstg	-55 ~ +125	°C	-
Package power	PD	310 ^{*2}	mW	-

^{*1} The input voltage range doesn't exceed absolute maximum ratings even including +0.5 V.

^{*2} Package dissipation will be reduced each 3.1mW/°C when the ambient temperature increases beyond 25 °C.

This IC is not designed to be X-ray proof.

● Recommended Operating Conditions

(Ta=-25°C ~+85°C)

Item	Symbol	Limit			Unit	Condition
		Min	Typ	Max		
Supply voltage (VDD)	V _{VDD}	1.65	1.80	1.95	V	Core
Supply voltage (VDDI2C)	V _{VDDI2C}	1.65	-	3.45	V	2-Wire,INT,ADR, XRST
Supply voltage (VDDIO1)	V _{VDDIO1}	1.65	-	3.45	V	GPIO[7:0]
Supply voltage (VDDIO2)	V _{VDDIO2}	1.65	-	3.45	V	GPIO[19:8]
2-Wire operating Frequency	F _{I2C}	-	-	400	KHz	Slave

● Package Specification (VBGA035W040)

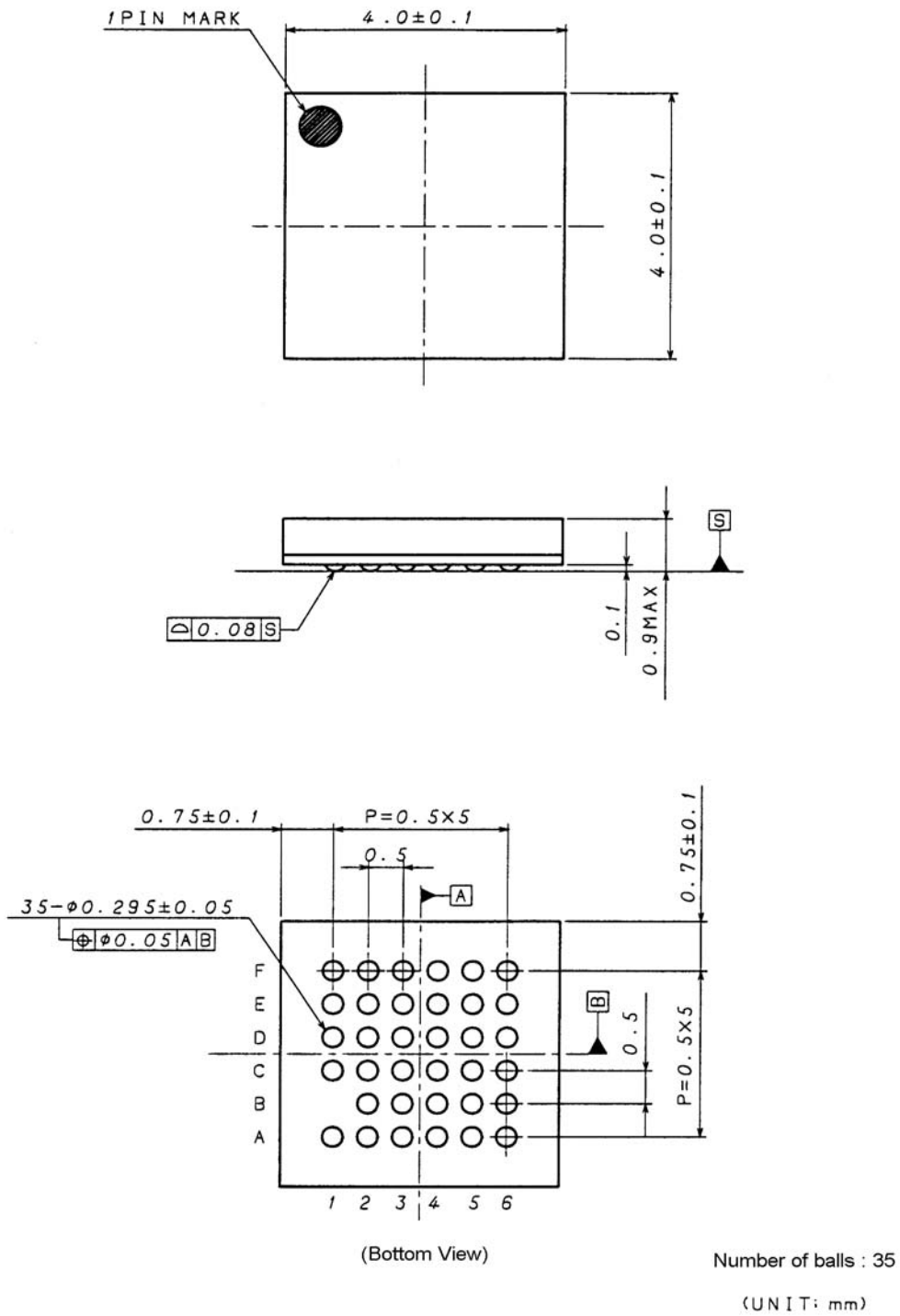

Fig.1 Package Specification

● Pin Diagram

F	VDD	GPIO0	GPIO1	GPIO3	GPIO5	VDDIO1
E	INT	GND	GPIO2	GPIO4	GPIO6	GPIO7
D	SCL	XRST	GND	GND	GPIO9	GPIO8
C	ADR	SDA	GND	GND	GPIO11	GPIO10
B		GPIO19	GPIO17	GPIO15	VDD	GPIO12
A	VDDI2C	GPIO18	GPIO16	GPIO14	GPIO13	VDDIO2
	1	2	3	4	5	6

Fig.2 Pin Diagram (Bottom View)

● Block Diagram

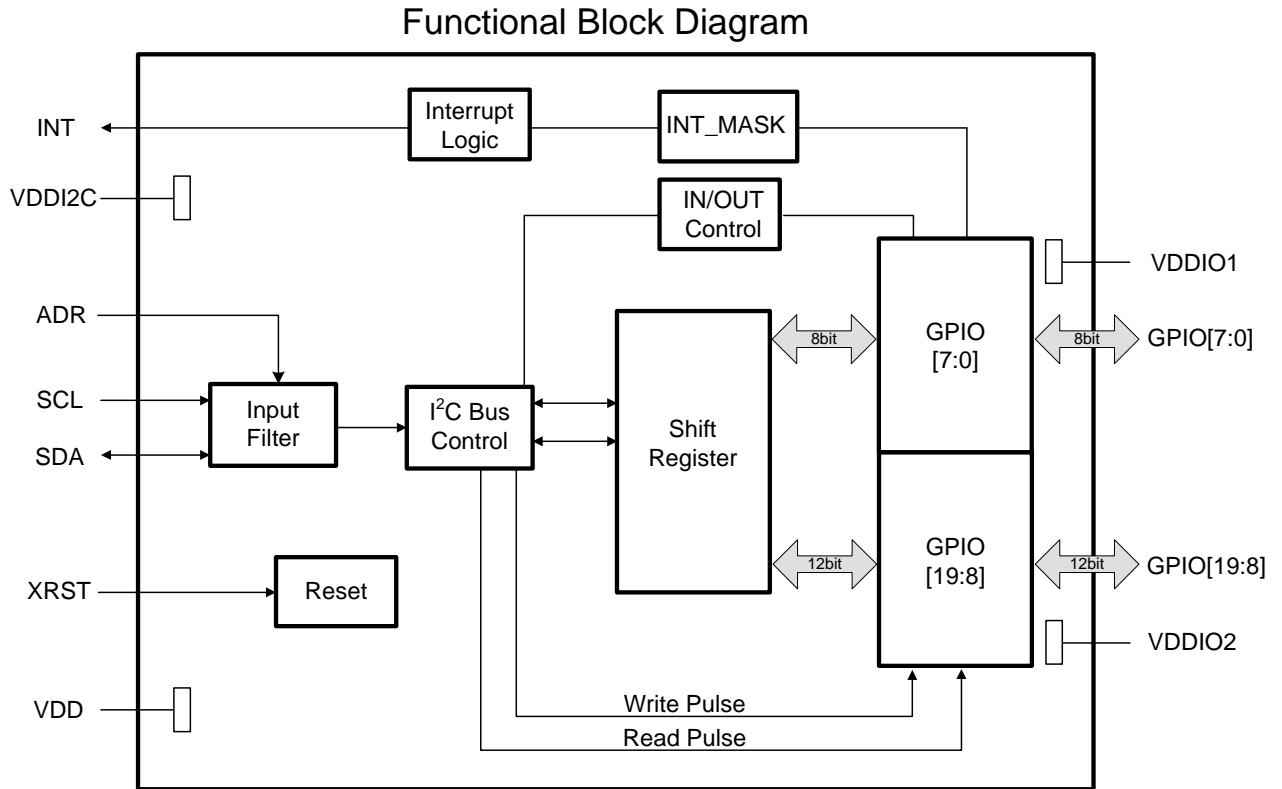

Fig.3 Functional Block Diagram

● Electrical Specification

VDD=1.8V, VDDIO=3.0V, VDDI2C=3.0V, Ta=25 °C, without output load conditions

Item	Symbol	Limit			Unit	comment
		Min.	Typ.	Max.		
Input H Voltage	V _{IH}	0.75xVDDIO	-	-	V	-
Input L Voltage	V _{IL}	-	-	0.25xVDDIO	V	-
Input H Current	I _{IH}	0	-	3	μA	-
Input L Current	I _{IL}	-3	-	0	μA	-
Output H Voltage	V _{OH}	VDDIO-0.2	-	-	V	I _{OH} =-1.0mA
Output L Voltage	V _{OL}	-	-	0.2	V	I _{OL} =1.0mA
SCL clk frequency	fSCL	-	-	400	KHz	
Bus free time	t _{BUF}	1.3	-	-	μs	
(repeat) Start condition Setup Time	t _{SU:STA}	0.6	-	-	μs	
(repeat) Start condition Hold Time	t _{HD:STA}	0.6	-	-	μs	
SCL Low Time	t _{LOW}	1.3	-	-	μs	
SCL High Time	t _{HIGH}	0.6	-	-	μs	
Data Setup Time	t _{SU:DAT}	100	-	-	ns	
Data Hold Time	t _{HD:DAT}	0	-	-	ns	
Stop condition Setup Time	t _{SU:STO}	0.6	-	-	μs	
Interrupt Valid	t _{IV}	-	-	0.1	μs	
Interrupt Reset	t _{IR}	-	-	1.0	μs	
Output Data Valid	t _{DV}	-	-	0.8	μs	
Input Data Setup Time	t _{DS}	100	-	-	ns	
Input Data Hold Time	t _{DH}	0	-	-	μs	
Standby Current	I _{STBY}	-	-	3.0	μA	

● Pin-out Functional Descriptions

1. Pin table

PIN No.	Land number	PIN name	I/O	Power source system	Function	Cell Type	XRST
1	A1	VDDI2C	-	-			
2	(NC)	-	-	-			
3	C3	GND	-	-			
4	C1	ADR	IN	VDDI2C		B	-
5	C2	SDA	INOUT	VDDI2C	Serial data inout for 2-Wire	A	Hi-z
6	D1	SCL	IN	VDDI2C	Clock for 2-Wire	B	-
7	D2	XRST	IN	VDDI2C	Reset (Low Active)	B	L
8	E1	INT	OUT	VDDI2C	Interrupt signal ^{*1}	C	- ^{*3}
9	E2	GND	-	-			
10	F1	VDD	-	-			
11	F2	GPIO0	INOUT	VDDIO1	General purpose inout. Pull-up to VDD ^{*2}	A	Hi-z
12	D3	GND	-	-			
13	F3	GPIO1	INOUT	VDDIO1	General purpose inout. Pull-up to VDD ^{*2}	A	Hi-z
14	E3	GPIO2	INOUT	VDDIO1	General purpose inout. Pull-up to VDD ^{*2}	A	Hi-z
15	F4	GPIO3	INOUT	VDDIO1	General purpose inout. Pull-up to VDD ^{*2}	A	Hi-z
16	E4	GPIO4	INOUT	VDDIO1	General purpose inout. Pull-up to VDD ^{*2}	A	Hi-z
17	F5	GPIO5	INOUT	VDDIO1	General purpose inout. Pull-up to VDD ^{*2}	A	Hi-z
18	E5	GPIO6	INOUT	VDDIO1	General purpose inout. Pull-up to VDD ^{*2}	A	Hi-z
19	F6	VDDIO1	-	-			
20	E6	GPIO7	INOUT	VDDIO1	General purpose inout. Pull-up to VDD ^{*2}	A	Hi-z
21	D4	GND	-	-			
22	D6	GPIO8	INOUT	VDDIO2	General purpose inout. Pull-up to VDD ^{*2}	A	Hi-z
23	D5	GPIO9	INOUT	VDDIO2	General purpose inout. Pull-up to VDD ^{*2}	A	Hi-z
24	C6	GPIO10	INOUT	VDDIO2	General purpose inout. Pull-up to VDD ^{*2}	A	Hi-z
25	C5	GPIO11	INOUT	VDDIO2	General purpose inout. Pull-up to VDD ^{*2}	A	Hi-z
26	B6	GPIO12	INOUT	VDDIO2	General purpose inout. Pull-up to VDD ^{*2}	A	Hi-z
27	B5	VDD	-	-			
28	A6	VDDIO2	-	-			
29	A5	GPIO13	INOUT	VDDIO2	General purpose inout. Pull-up to VDD ^{*2}	A	Hi-z
30	C4	GND	-	-			
31	A4	GPIO14	INOUT	VDDIO2	General purpose inout. Pull-up to VDD ^{*2}	A	Hi-z
32	B4	GPIO15	INOUT	VDDIO2	General purpose inout. Pull-up to VDD ^{*2}	A	Hi-z
33	A3	GPIO16	INOUT	VDDIO2	General purpose inout. Pull-up to VDD ^{*2}	A	Hi-z
34	B3	GPIO17	INOUT	VDDIO2	General purpose inout. Pull-up to VDD ^{*2}	A	Hi-z
35	A2	GPIO18	INOUT	VDDIO2	General purpose inout. Pull-up to VDD ^{*2}	A	Hi-z
36	B2	GPIO19	INOUT	VDDIO2	General purpose inout. Pull-up to VDD ^{*2}	A	Hi-z

^{*1} The Low Active or High Active of interrupt output level and specific bit mask control are decided by internal register value.

^{*2} When IOSEL register is set to "1", please pull-up IO output to the same value as VDDIO1 or VDDIO2 voltages respectively.

2. Equivalent IO circuit diagram

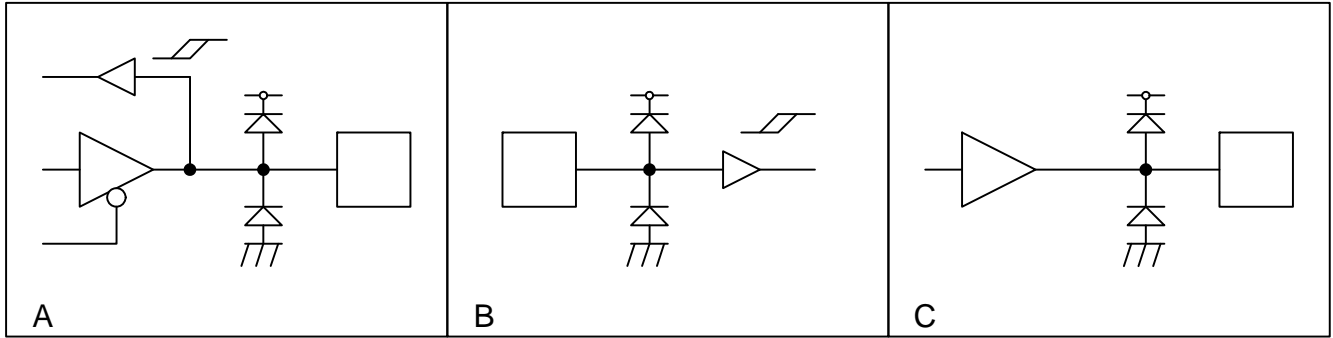

Fig.4 Equivalent IO circuit diagram

● Functional Description

1 2-Wire Bus Interface

1.1 Slave address

Please pull-up SDA and SCL to the same potential of voltage as DVDDI2C.

BU8272GUW is controlled by using an on-chip 2-Wire slave interface. Two kinds of the device address, "0001111" at ADR="1" or "0001000" at ADR="0" can be used. The transfer bit rate supports Fast-mode up to max 400Kbps.

	A7	A6	A5	A4	A3	A2	A1	W/R
ADR=0	0	0	0	1	0	0	0	0/1
ADR=1	0	0	0	1	1	1	1	

2-Wire Slave address

Fig. 5 Slave address

1.2 Data transfer

One bit of data is transferred during SCL = "1". During the bit transfer SCL = "1" cycle, the signal SDA should keep the value. If SDA changes during SCL = "1", a START condition or STOP condition occur and it is interpreted as a control signal.

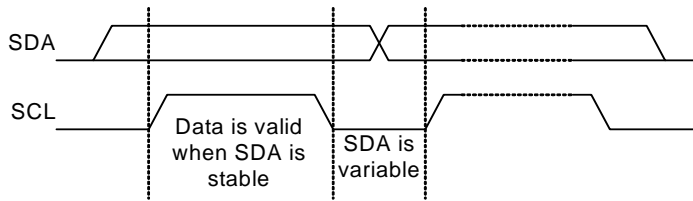

Fig. 6 Data transfer

1.3 START-STOP conditions

When SDA and SCL are "1", the data isn't transferred on the 2-wire bus. If SCL remains "1" and SDA transfers from "1" to "0", it means a "Start condition" is occurred and access is started.

If SCL remains "1" and SDA transfers from "0" to "1", it means a "Stop condition" is occurred and access is stopped.

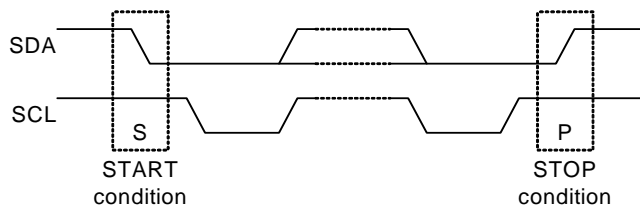

Fig. 7 START-STOP conditions

1.4 Acknowledge

After start condition is occurred, 8 bits data will be transferred. Then the "Master" opens SDA and "Slave" de-asserts SDA to "0" as an "Acknowledge" returned.

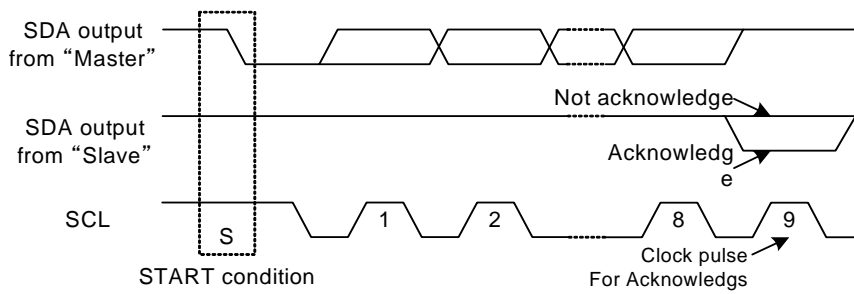

Fig. 8 Acknowledge

1.5 Writing protocol

A writing protocol is shown in Fig.8-5 below. GPIO register address in BU8272GUW is transferred after one byte of slave address with a write command. The 3rd byte data is written to internal register which defined by the 2nd byte. After the each byte transfer, the register address will be automatically increased. However, when the register address increased to the final address (09h), it will be reset to (00h) after the byte transfer. GPIO register address (00h) is assigned to GPIO register[7:0], the register address (01h) is assigned to GPIO register[15:8], and the register address (02h) is assigned to GPIO register[19:16]. Only the 4 bits LSB data are valid in the register with GPIO register address (02h).

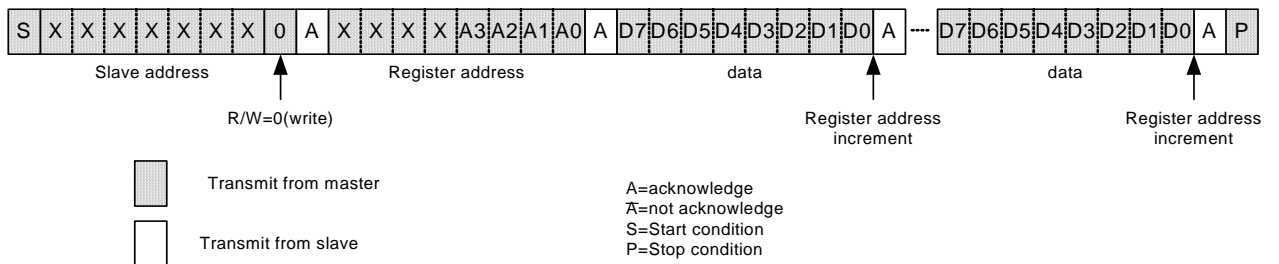

Fig. 9 Writing protocol

1.6 Reading protocol

After Writing the slave address and Read/Write command bits, the next byte is read. The reading register address is next of previous accessed address. Therefore, the data is read with address increment. When the address is increased to the last, the following read address will be reset to (00h). When the GPIO port [19:16] is read, 4 bits of "0" will be added from MSB, and the value of 4 bits from GPIO port [19:16] is read from 2-wire interface.

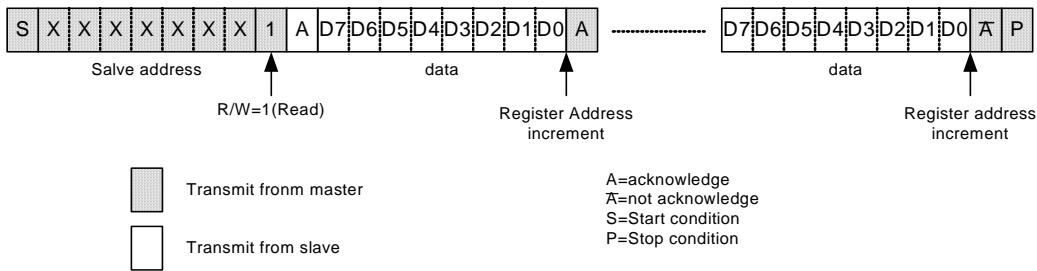

Fig. 10 Readout protocol

1.7 Complex reading protocol

After the specifying the internal register address, a resending start condition occurs and the direction of data transfer is changed then reading access is done. Therefore, the data is read followed by address increment. If the address is increased to the last, it will be reset to (00h).

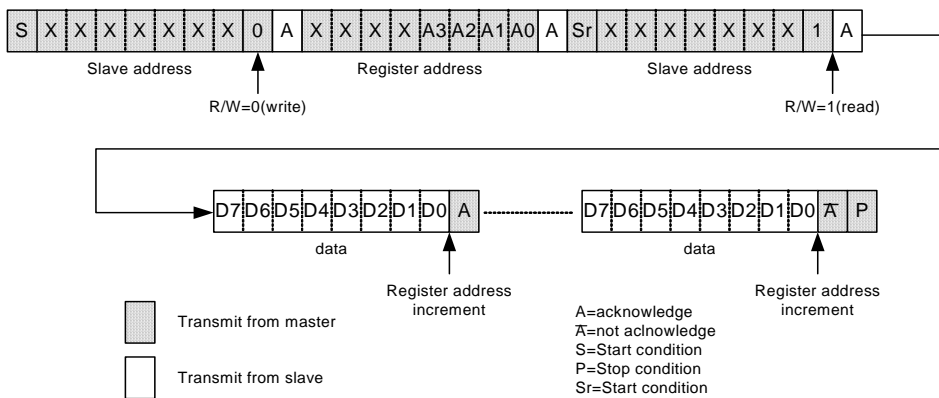

Fig. 11 Complex reading protocol

1.8 Timing Diagram

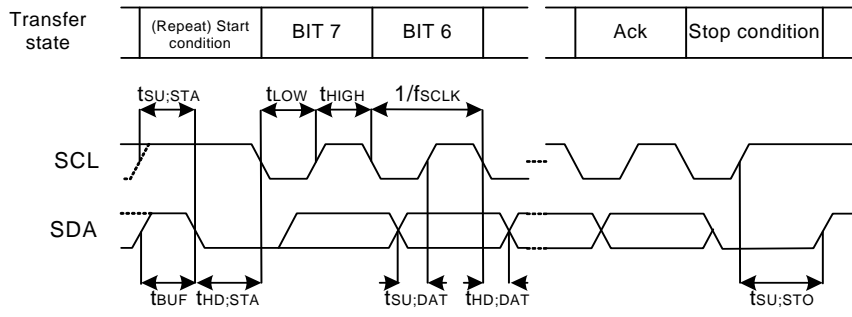

Fig. 12 Timing Diagram

2. GPIO·INT Interface

The default mode of all GPIO [19:0] ports are input mode upon the power-on. By setting the specific bit of Interrupt Mask Sel register to "1", the corresponding bit of Interrupt will be masked. There are two kinds of ways to control input / output operations. The first way is to change read / write register value in each corresponding bit. Second way is to write each GPIO register a "0" value for 'Output operation' and a "1" value for 'input operation'. It is necessary to pull up the output to the same voltage value as the corresponding I/O power supply in the second way.

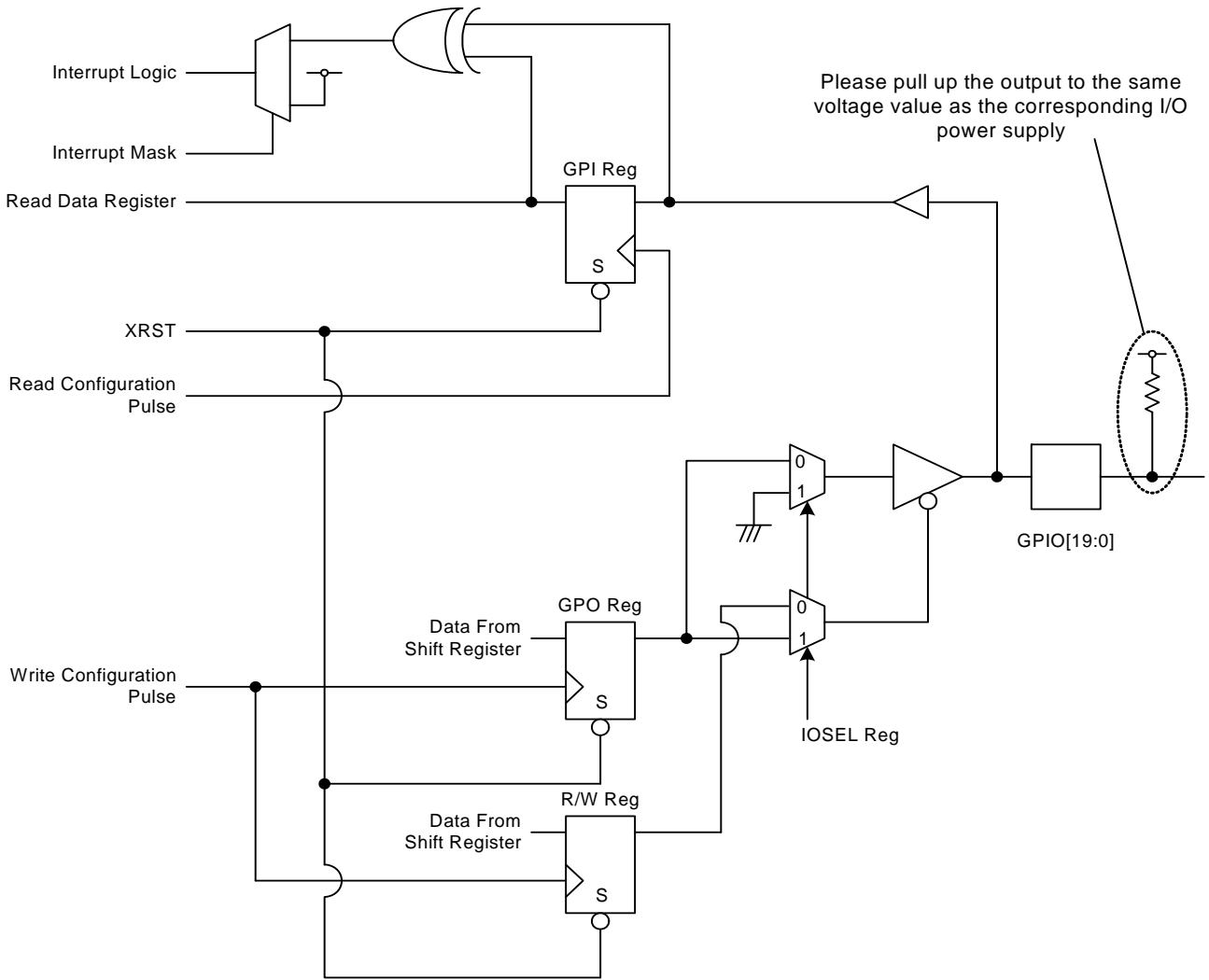

Fig. 13 GPIO · INT system

2.1 Write to GPIO Port

After setting the internal register address, the data from master is written from MSB. After Acknowledge is returned, the value of each GPIO port will be changed.

• IOSEL=1

In the condition that IOSEL register is "1", after sending Acknowledge, a value "0" is output from the GPIO port which the corresponding bit is transferred as '0', and a input-mode(Hi-Z) is output from GPIO port which the corresponding bit is transferred as '1'.

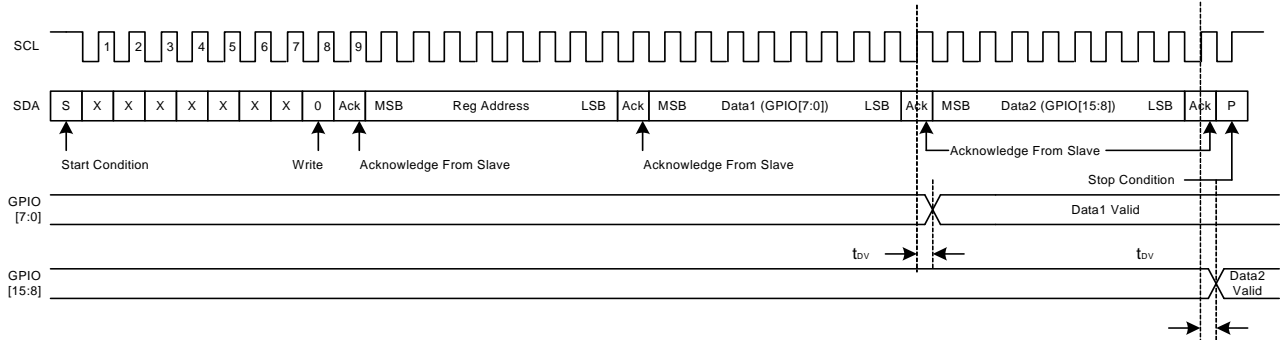

Fig. 14 Write to GPIO port (Pull-up-mode)

• IOSEL=0

In the condition that IOSEL register is "0", data input or output is defined by the value of RWSEL register. Therefore, after "0" is written to each bit of RWSEL register, the data is output from GPIO port. If "0" is written to RWSEL register at first, the data will be output immediately from the GPIO port after the acknowledge signaling.

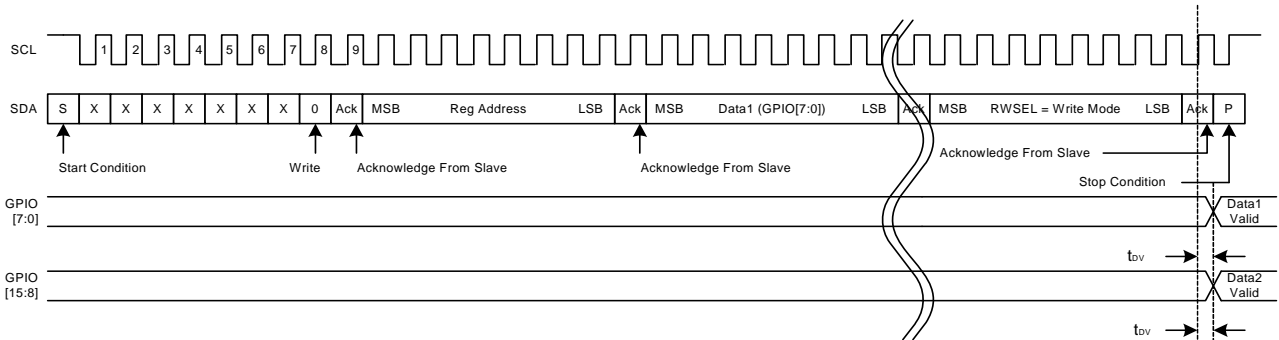

Fig. 15 Write to GPIO port (RWSEL-mode)

2.2 Read From GPIO Port

After slave address and R/W bit is written, the GPIO ports value will be read into the GPIO registers. (refer to section 8.1.6 for 2-wire reading protocol.) The data fixed between tow consecutive acknowledges will be transferred to the Master.

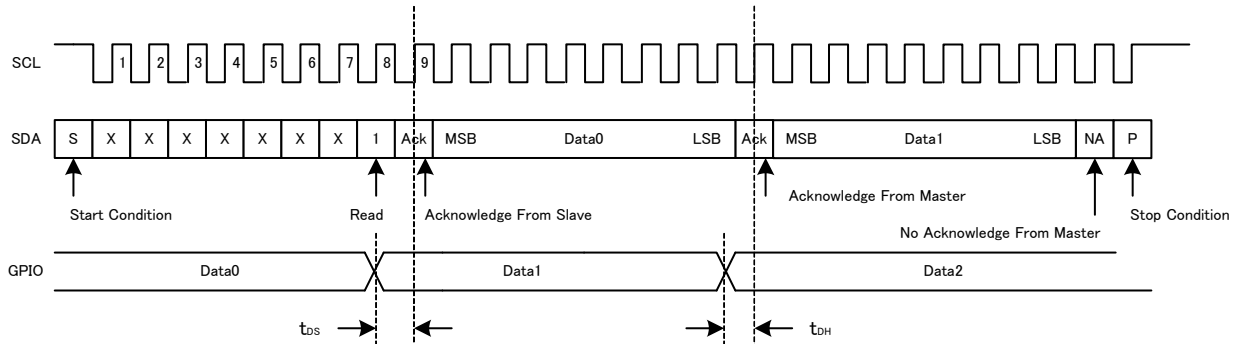

Fig. 16 Read from GPIO port

2.3 Interrupt Valid/Reset

The transition of each GPIO port de-asserts the interrupt signal (INT), generates the interrupt signal by asserting the INT after each acknowledge signaling.

Either a "High-Active" or a "Low-Active" interrupt signaling can be defined by changing the INTSEL register value beforehand.

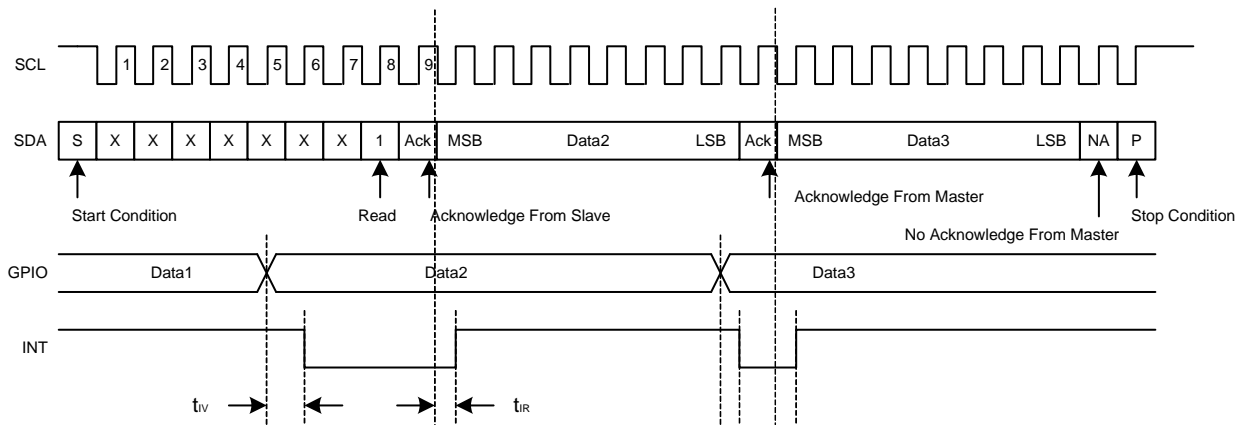

Fig. 17 Interrupt Valid/Reset

● The Setting Registers

When setting address is written beyond 00h~09h, the register address will be forced to value 00h.

When the final address is set to 09h, then the next address 00h will be written.

By making XRST "Low", the setting register value will be initialed shown in following register map.

1. Register map

Addr	Init	Type	D7	D6	D5	D4	D3	D2	D1	D0
00h	ffh	R/W	GPIO7	GPIO6	GPIO5	GPIO4	GPIO3	GPIO2	GPIO1	GPIO0
01h	ffh	R/W	GPIO15	GPIO14	GPIO13	GPIO12	GPIO11	GPIO10	GPIO9	GPIO8
02h	0fh	R/W	-	-	-	-	GPIO19	GPIO18	GPIO17	GPIO16
03h	00h	R/W	MASK7	MASK6	MASK5	MASK4	MASK3	MASK2	MASK1	MASK0
04h	00h	R/W	MASK15	MASK14	MASK13	MASK12	MASK11	MASK10	MASK9	MASK8
05h	00h	R/W	-	-	-	-	MASK19	MASK18	MASK17	MASK16
06h	ffh	R/W	RWSEL7	RWSEL6	RWSEL5	RWSEL4	RWSEL3	RWSEL2	RWSEL1	RWSEL0
07h	ffh	R/W	RWSEL1 5	RWSEL1 4	RWSEL1 3	RWSEL1 2	RWSEL1 1	RWSEL1 0	RWSEL9	RWSEL8
08h	0fh	R/W	-	-	-	-	RWSEL1 9	RWSEL1 8	RWSEL1 7	RWSEL1 6
09h	03h	R/W	-	-	-	-	-	INTSEL	IOSEL2	IOSEL1

2. Register functional explanations

Symbol	Addr	Init	Description
GPIO7 ~ GPIO0	00h	ffh	Read or write data of GPIO bit 0 to 7.
GPIO15 ~ GPIO8	01h	ffh	Read or write data of GPIO bit 8 to 15.
GPIO19 ~ GPIO16	02h	0fh	Read or write data of GPIO bit 16 to bit 19. In writing mode, 4 bits of MSB is ignored and in reading mode, 4 bits of "0" is filled up from MSB.
MASK7 ~ MASK0	03h	00h	0: Interrupt is not masked when "0" is written to GPIO bit 0 to 7 1: Interrupt is masked when "0" is written to GPIO bit 0 to 7
MASK15 ~ MASK8	04h	00h	0: Interrupt is not masked When "0" is written to GPIO bit 8 to 15 1: Interrupt is masked When "0" is written to GPIO bit 8 to 15
MASK19 ~ MASK16	05h	00h	0: Interrupt is not masked when "0" is written to GPIO bit 16 to 19 1: Interrupt is masked when "0" is written to GPIO bit 16 to 19 In writing mode, 4 bit of MSB is ignored and in reading mode, 4 bits of "0" is filled up from MSB.
RWSEL7 ~ RWSEL0	06h	ffh	0: GPIO bit 0 through 7 becomes output mode. 1: GPIO bit 0 through 7 becomes input mode.
RWSEL15 ~ RWSEL8	07h	Ffh	0: GPIO bit 8 through 15 becomes output mode. 1: GPIO bit 8 through 15 becomes input mode.
RWSEL19 ~ RWSEL16	08h	0fh	0: GPIO bit 16 through 19 becomes output mode. 1: GPIO bit 16 through 19 becomes input mode.
IOSEL1	09h	1h	0: RWSEL bit 0 through 7 becomes available. 1: Change to pull-up mode.
IOSEL2		1h	0: RWSEL bit 8 through 19 becomes available. 1: Change to pull-up mode.
INTSEL		0h	0: Make Interrupt "Low active". 1: Make Interrupt "High active".

● Appendix

1. About difference between I2C and 2-Wire

2-wire interface logic uses a normal IN/OUT cell (Hi-Z or only "0" output) instead of an Open-Drain cell in normal I2C interface. For this reason, the VDDI2C voltage level must be same as the connected other normal I2C masters'. Therefore, any other I2C slave with same bus level can be connected to the bus.

2 .In case of illegal access ^{*1} during 2-Wire data transference

The current data will be canceled and next access is necessary.

^{*1}In case of a consecutive Start-condition and Stop-condition occurred.

In case of Resend-condition or Stop-condition occurred during a slave address or R/W bit witting cycles.

In case of Resend-condition or Stop-condition occurred during data witting cycles.

3. About the handling of the no using GPIO port

Any no using GPIO port must be pulled-up or connected to GND. In order to prevent from any unexpected interrupt happening when a no using GPIO is connected to GND, the corresponding bit of GPIO Mask register must be disabled by Mask register access, or simply read the GPIO value into corresponding internal GPIO port register. The no using GPIO port power supply (VDDIO1 or VDDIO2) must be connected to the voltage value defined in this specification, never left it open.

4. Caution of power on sequence

The BU8272GUW can not works correctly even one of the power supply among the core power supply (VDD) and the I/O power supply (VDDI2C, VDDIO1, VDDIO2) is not connected to specified conditions described in this specification.

The power on sequence must be designed to give core power supply first then I/O power. Inversely, the I/O power supply must be switched off before the core power down in the device power down sequence.

5. Reset release timing

Core power supply (VDD) and I/O power supply (VDDI2C, VDDIO1, VDDIO2) first. Afterwards, release XRST.

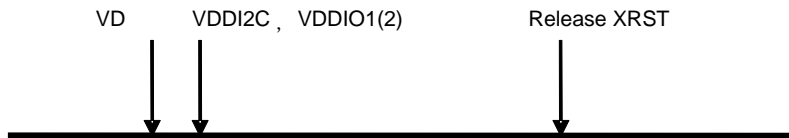

●Ordering part number

B	U
---	---

Part No.

8	2	7	2
---	---	---	---

Part No.

G	U	W
---	---	---

Package
GUW:
VBGA035W040

E	2
---	---

Packaging and forming specification
E2: Embossed tape and reel

VBGA035W040

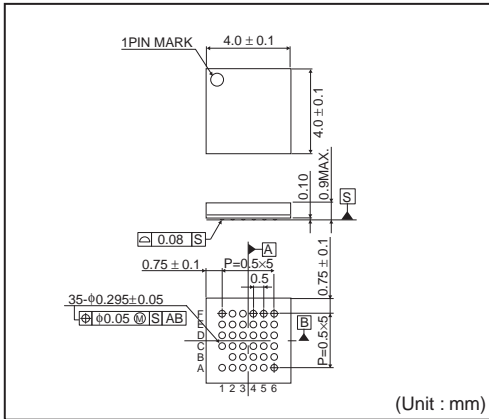

<Tape and Reel information>

Tape	Embossed carrier tape (with dry pack)
Quantity	2500pcs
Direction of feed	E2 (The direction is the 1pin of product is at the upper left when you hold reel on the left hand and you pull out the tape on the right hand)

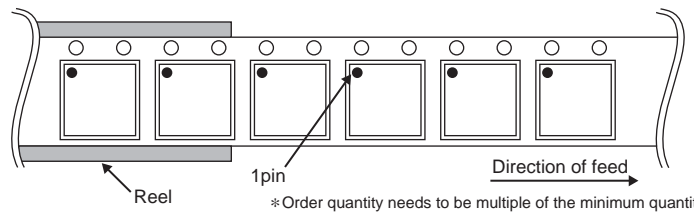

Notes

No copying or reproduction of this document, in part or in whole, is permitted without the consent of ROHM Co.,Ltd.

The content specified herein is subject to change for improvement without notice.

The content specified herein is for the purpose of introducing ROHM's products (hereinafter "Products"). If you wish to use any such Product, please be sure to refer to the specifications, which can be obtained from ROHM upon request.

Examples of application circuits, circuit constants and any other information contained herein illustrate the standard usage and operations of the Products. The peripheral conditions must be taken into account when designing circuits for mass production.

Great care was taken in ensuring the accuracy of the information specified in this document. However, should you incur any damage arising from any inaccuracy or misprint of such information, ROHM shall bear no responsibility for such damage.

The technical information specified herein is intended only to show the typical functions of and examples of application circuits for the Products. ROHM does not grant you, explicitly or implicitly, any license to use or exercise intellectual property or other rights held by ROHM and other parties. ROHM shall bear no responsibility whatsoever for any dispute arising from the use of such technical information.

The Products specified in this document are intended to be used with general-use electronic equipment or devices (such as audio visual equipment, office-automation equipment, communication devices, electronic appliances and amusement devices).

The Products specified in this document are not designed to be radiation tolerant.

While ROHM always makes efforts to enhance the quality and reliability of its Products, a Product may fail or malfunction for a variety of reasons.

Please be sure to implement in your equipment using the Products safety measures to guard against the possibility of physical injury, fire or any other damage caused in the event of the failure of any Product, such as derating, redundancy, fire control and fail-safe designs. ROHM shall bear no responsibility whatsoever for your use of any Product outside of the prescribed scope or not in accordance with the instruction manual.

The Products are not designed or manufactured to be used with any equipment, device or system which requires an extremely high level of reliability the failure or malfunction of which may result in a direct threat to human life or create a risk of human injury (such as a medical instrument, transportation equipment, aerospace machinery, nuclear-reactor controller, fuel-controller or other safety device). ROHM shall bear no responsibility in any way for use of any of the Products for the above special purposes. If a Product is intended to be used for any such special purpose, please contact a ROHM sales representative before purchasing.

If you intend to export or ship overseas any Product or technology specified herein that may be controlled under the Foreign Exchange and the Foreign Trade Law, you will be required to obtain a license or permit under the Law.



Thank you for your accessing to ROHM product informations.
More detail product informations and catalogs are available, please contact us.

ROHM Customer Support System

<http://www.rohm.com/contact/>