

USB Switch ICs

DPDT Type

(Double Pole Double Throw)



BD11600NUX

No.11103EAT03

●Description

BD11600NUX is DPDT analog switches handling with USB2.0 high-speed that have both a low resistance and a low capacitance. Moreover, this is widely guaranteed from 2.5V to 5.5V as for the range of the power-supply voltage. This has a low consumption mode by making OE "H" and the multi-selector by making the combination of OE "L" and S. The electrostatic discharge protection circuit is built-in in all terminals.

●Features

- 1) VCC Operation from 2.5V to 5.5V.
- 2) $3\ \Omega$ switches between the input to the output.
- 3) Low Capacity 2ch Analog SW.
- 4) 10-Pin SON Package. (3.0mm x 2.0mm, Height=0.6mm, 0.5mm pitch)

●Applications

Digital Still Cameras, Digital Video Camcorders, Portable Navigation Devices, TV, Portable DVD Players, Portable Game Systems, Personal computers, PDA, Mobile phones

●Line up matrix

Parameter	BD11600NUX	BD11601NUX
Supply Quiescent Current	18 μ A	
Input voltage range	2.5~5.5 V	
Switch ON Resistance (VIN=0 V)	3 Ω	2.5 Ω
Switch ON Capacitance	6 pF	
Configuration	DPDT	DPST
Package	VSON010X3020	VSON008X2020

●Absolute maximum ratings (Ta=25°C)

Parameter	Symbol	Ratings	Unit	Conditions
Input supply voltage	Vmax	-0.5~7.0	V	D+,D-,1D+,1D-,2D+,2D- Pins
Input supply voltage	Vmax	-0.3~7.0	V	Other Pins
Power dissipation	Pd	1.925	W	*1
Operating temperature range	Topr	-40~+85	°C	
Storage temperature range	Tstr	-55~+150	°C	

*1 When using more than at Ta=25°C, it is reduced 15.4 mW per 1°C. ROHM specification board 70mm x 70mm mounting.

●Operating conditions (Ta=-40~+85°C)

Parameter	Symbol	Ratings	Unit	Conditions
Input voltage range (VCC)	VCC	2.5~5.5	V	

* This product does not especially designed to be protected from radioactivity.

●Electrical characteristics (Unless otherwise noted, Ta = 25°C, VCC=5.0V)

Parameter	Symbol	Limits			Unit	Conditions
		Min.	Typ.	Max.		
Supply Quiescent Current 1	ICC1	-	1	3	μA	SW1, 2=OFF
Supply Quiescent Current 2	ICC2	-	18	40	μA	SW1=ON
Supply Quiescent Current 3	ICC3	-	19	40	μA	SW2=ON
Switch ON Resistance 1 (SW1, 2)	Ron1	-	3	6	Ω	VIN=0V
Switch ON Resistance 2 (SW1, 2)	Ron2	-	3.5	6	Ω	VIN=2.4V
Off-Leakage Current	Ioff	-2	0	2	μA	SW1, 2=OFF
On-Leakage Current	Ion	-2	0	2	μA	VCC>VIN, SW1, 2=ON
Switch Input Range	VIN	-0.5	-	5.5	V	SW1, 2=ON
Switch OFF Capacitance (SW1, 2)	Coff	-	4	-	pF	
Switch ON Capacitance (SW1, 2)	Con	-	6	-	pF	
Input "L" level (S, \overline{OE})	VIL	-	-	0.5	V	
Input "H" level (S, \overline{OE})	VIH	1.1	-	-	V	

●Electrical characteristic curves (Reference data)

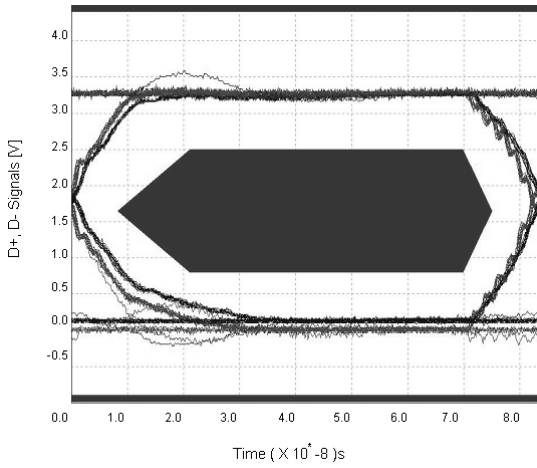

Fig.1
Eye Pattern Full Speed

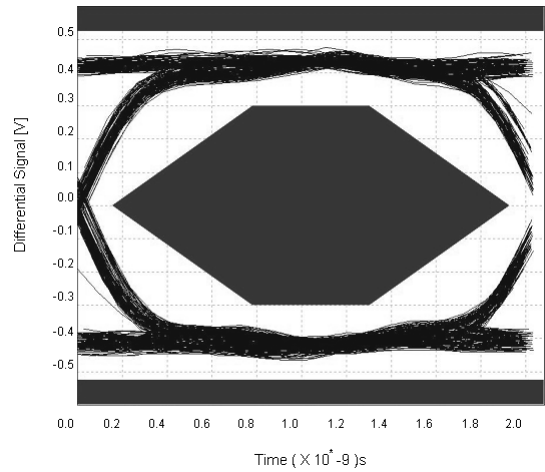

Fig.2
Eye Pattern High Speed

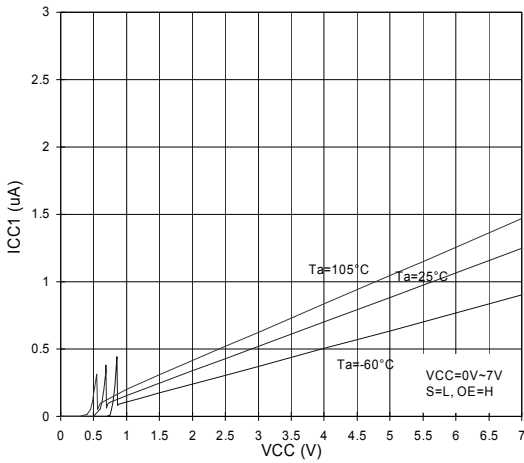

Fig.3
ICC vs Input Voltage (SW OFF)

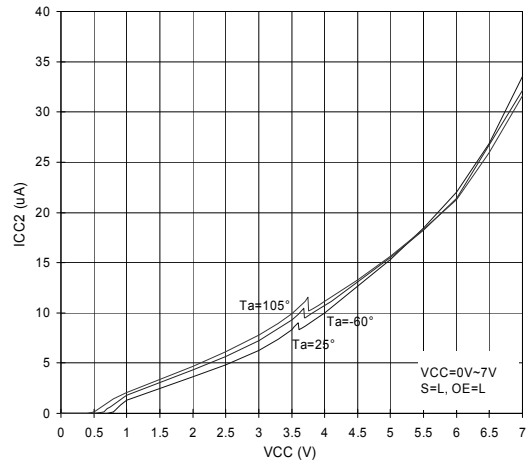

Fig.4
ICC vs Input Voltage (SW ON)

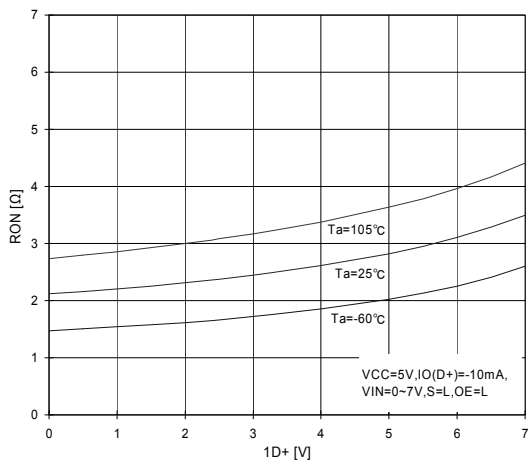

Fig.5
Ron vs Input Voltage

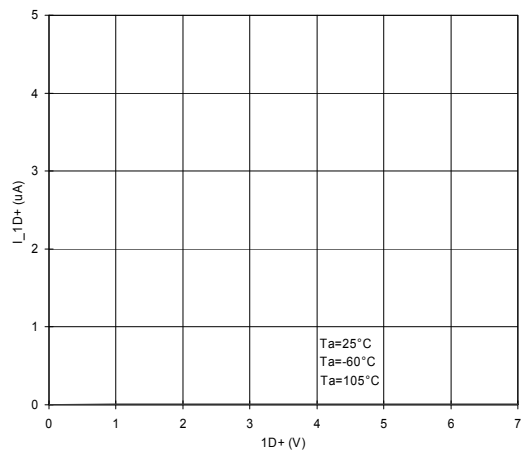

Fig.6
Leak current vs Input Voltage(SW OFF)

●Block diagram and pin configuration

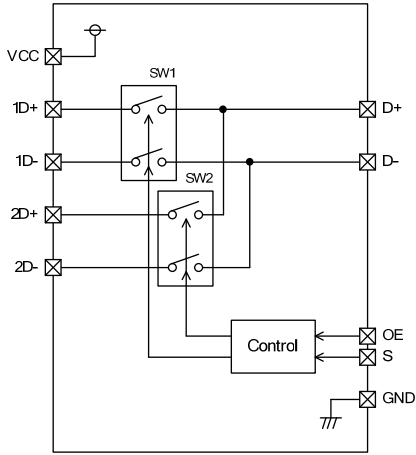

Fig.7
Block diagram

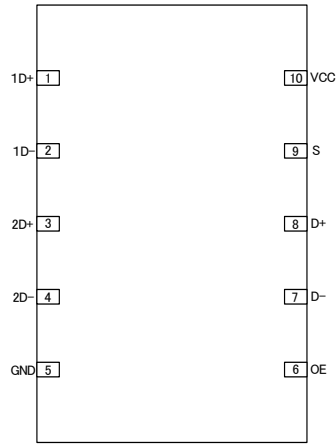
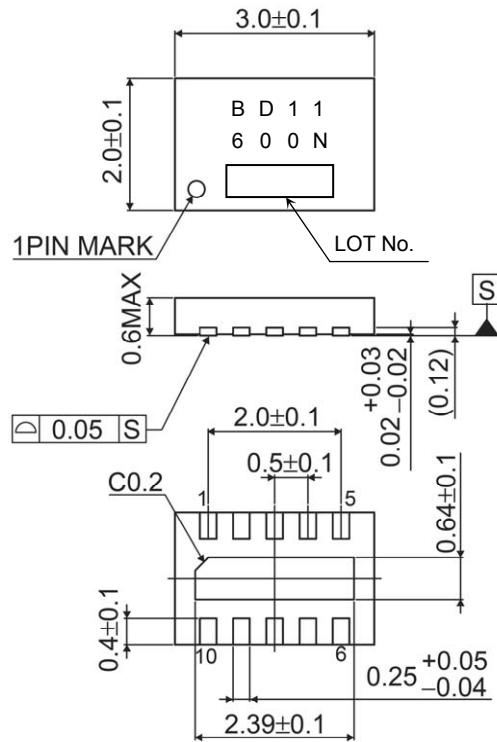

Fig.8
Pin configuration

●Package Dimensions



(Unit : mm)

Fig.9
Package Dimensions

●Pin Description

Pin NO.	Terminal circuit	Pin Name	I/O	Function
1	A	1D+	O	Analog SW terminal.
2	B	1D-	O	
3	C	2D+	O	
4	D	2D-	O	
5	-	GND	-	Ground Pin.
6	E	OE	I	Bus-Switch Analog Pin.
7	F	D-	I	Analog SW terminal.
8	G	D+	I	
9	H	S	I	Select Input Pin.
10	-	VCC	-	Power Supply.

●Truth Table

\overline{OE}	S	SW1	SW2	Signal Pass
H	L	OFF	OFF	ALL OFF
H	H	OFF	OFF	ALL OFF
L	L	ON	OFF	1D+↔D+, 1D-↔D-
L	H	OFF	ON	2D+↔D+, 2D-↔D-

●Equivalent Circuit

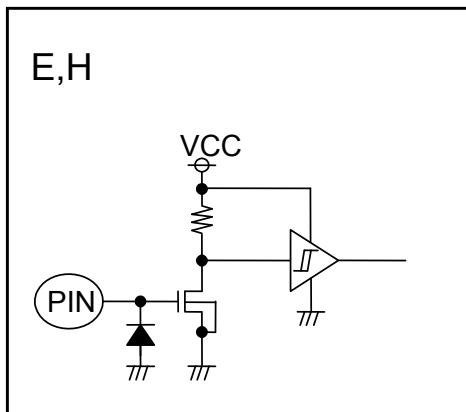
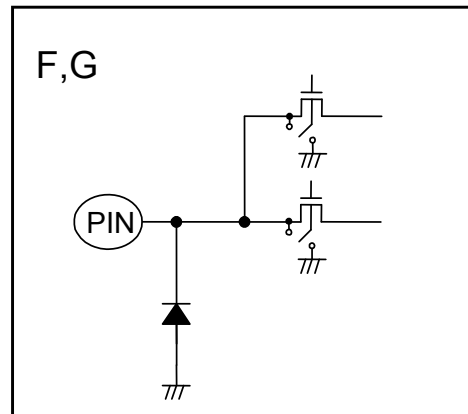
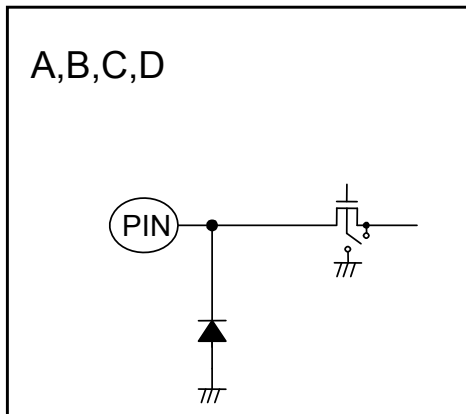

●How to select parts of application

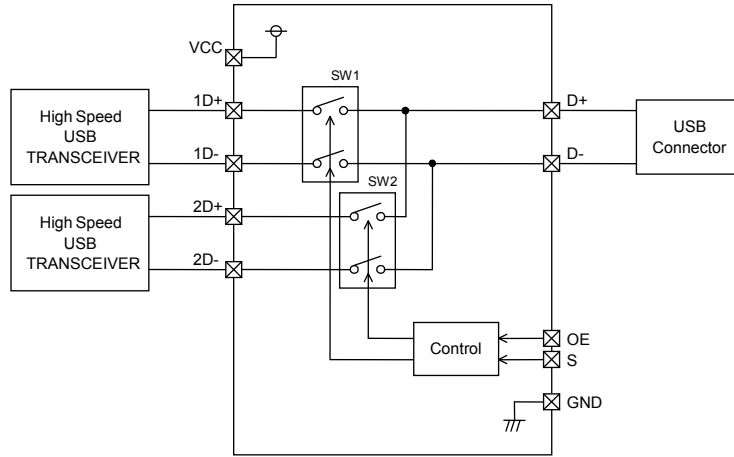

Fig.10
Application circuit of multi-USB TRANSCEIVER

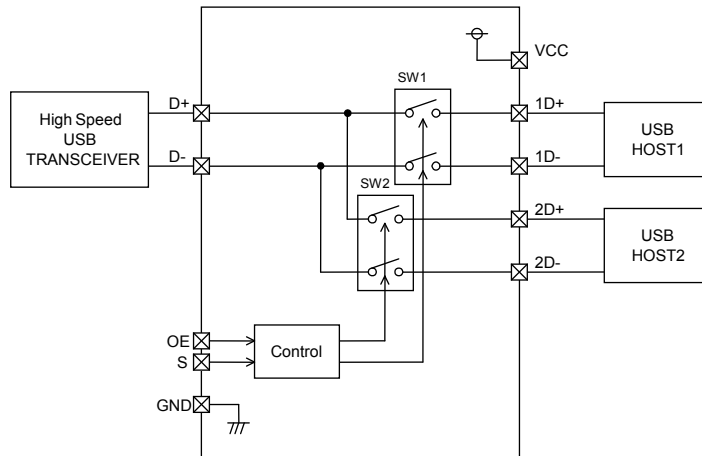

Fig.11
Application circuit of two communicating with two USB HOST

●Parameter Measurement Information

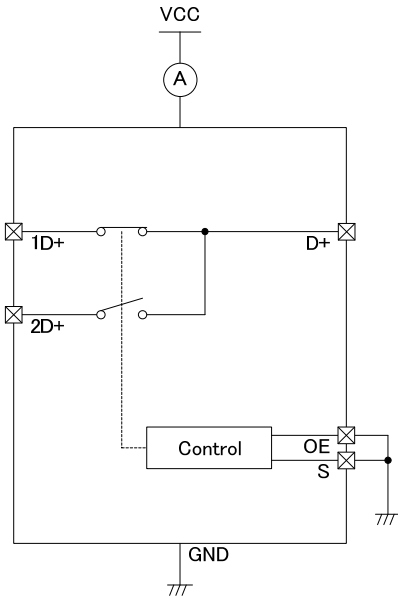

Fig.12
SW1 ON-State ICC

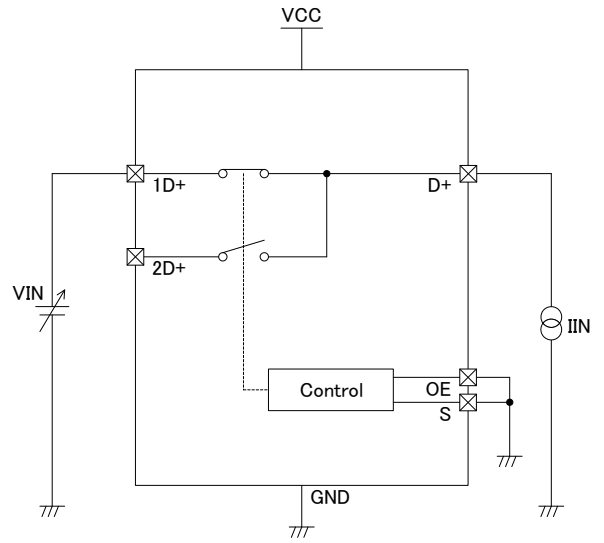

Fig.13
ON-State Resistance (Ron)

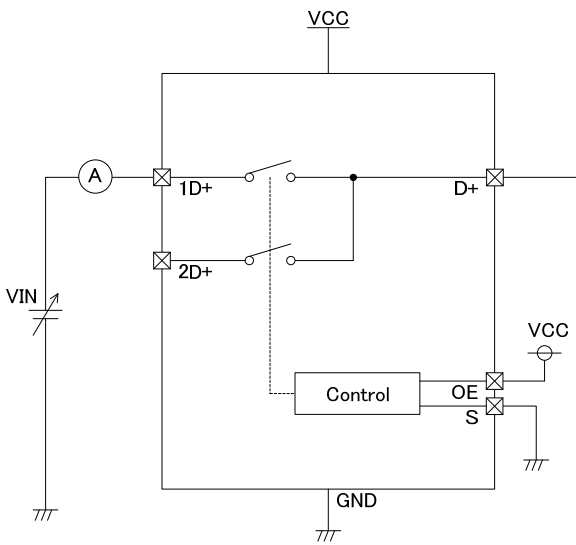

Fig.14
OFF-State Leakage current

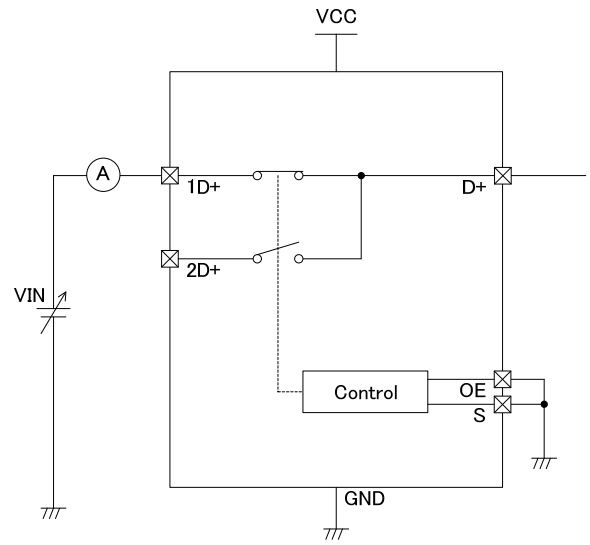

Fig.15
ON-State Leakage current

●Notes for use

- (1) Absolute maximum ratings
If applied voltage (VCC), operating temperature range (Topr), or other absolute maximum ratings are exceeded, there is a risk of damage. Since it is not possible to identify short, open, or other damage modes, if special modes in which absolute maximum ratings are exceeded are assumed, consider applying fuses or other physical safety measures.
- (2) Recommended operating range
This is the range within which it is possible to obtain roughly the expected characteristics. For electrical characteristics, it is those that are guaranteed under the conditions for each parameter. Even when these are within the recommended operating range, voltage and temperature characteristics are indicated.
- (3) Reverse connection of power supply connector
There is a risk of damaging the LSI by reverse connection of the power supply connector. For protection from reverse connection, take measures such as externally placing a diode between the power supply and the power supply pin of the LSI.
- (4) Power supply lines
In the design of the board pattern, make power supply and GND line wiring low impedance. When doing so, although the digital power supply and analog power supply are the same potential, separate the digital power supply pattern and analog power supply pattern to deter digital noise from entering the analog power supply due to the common impedance of the wiring patterns. Similarly take pattern design into account for GND lines as well. Furthermore, for all power supply pins of the LSI, in conjunction with inserting capacitors between power supply and GND pins, when using electrolytic capacitors, determine constants upon adequately confirming that capacitance loss occurring at low temperatures is not a problem for various characteristics of the capacitors used.
- (5) GND voltage
Make the potential of a GND pin such that it will be the lowest potential even if operating below that. In addition, confirm that there are no pins for which the potential becomes less than a GND by actually including transition phenomena.
- (6) Shorts between pins and misinstallation
When installing in the set board, pay adequate attention to orientation and placement discrepancies of the LSI. If it is installed erroneously, there is a risk of LSI damage. There also is a risk of damage if it is shorted by a foreign substance getting between pins or between a pin and a power supply or GND.
- (7) Operation in strong magnetic fields
Be careful when using the LSI in a strong magnetic field, since it may malfunction.
- (8) Inspection in set board
When inspecting the LSI in the set board, since there is a risk of stress to the LSI when capacitors are connected to low impedance LSI pins, be sure to discharge for each process. Moreover, when getting it on and off of a jig in the inspection process, always connect it after turning off the power supply, perform the inspection, and remove it after turning off the power supply. Furthermore, as countermeasures against static electricity, use grounding in the assembly process and take appropriate care in transport and storage.
- (9) Input pins
Parasitic elements inevitably are formed on an LSI structure due to potential relationships. Because parasitic elements operate, they give rise to interference with circuit operation and may be the cause of malfunctions as well as damage. Accordingly, take care not to apply a lower voltage than GND to an input pin or use the LSI in other ways such that parasitic elements operate. Moreover, do not apply a voltage to an input pin when the power supply voltage is not being applied to the LSI. Furthermore, when the power supply voltage is being applied, make each input pin a voltage less than the power supply voltage as well as within the guaranteed values of electrical characteristics.
- (10) Ground wiring pattern
When there is a small signal GND and a large current GND, it is recommended that you separate the large current GND pattern and small signal GND pattern and provide single point grounding at the reference point of the set so that voltage variation due to resistance components of the pattern wiring and large currents do not cause the small signal GND voltage to change. Take care that the GND wiring pattern of externally attached components also does not change.
- (11) Externally attached capacitors
When using ceramic capacitors for externally attached capacitors, determine constants upon taking into account a lowering of the rated capacitance due to DC bias and capacitance change due to factors such as temperature.
- (12) Thermal design
Perform thermal design in which there are adequate margins by taking into account the permissible dissipation (Pd) in actual states of use.

●Power Dissipation

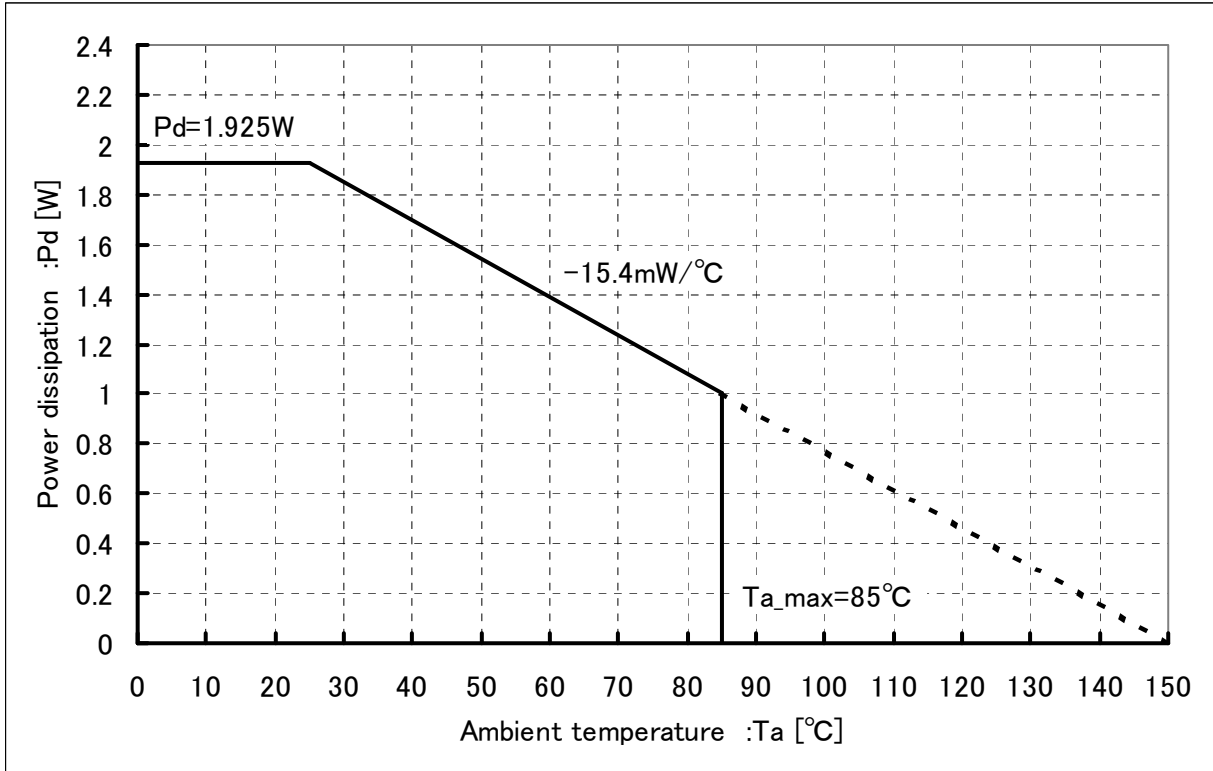

Fig.16
Power dissipation

Notes

No copying or reproduction of this document, in part or in whole, is permitted without the consent of ROHM Co.,Ltd.

The content specified herein is subject to change for improvement without notice.

The content specified herein is for the purpose of introducing ROHM's products (hereinafter "Products"). If you wish to use any such Product, please be sure to refer to the specifications, which can be obtained from ROHM upon request.

Examples of application circuits, circuit constants and any other information contained herein illustrate the standard usage and operations of the Products. The peripheral conditions must be taken into account when designing circuits for mass production.

Great care was taken in ensuring the accuracy of the information specified in this document. However, should you incur any damage arising from any inaccuracy or misprint of such information, ROHM shall bear no responsibility for such damage.

The technical information specified herein is intended only to show the typical functions of and examples of application circuits for the Products. ROHM does not grant you, explicitly or implicitly, any license to use or exercise intellectual property or other rights held by ROHM and other parties. ROHM shall bear no responsibility whatsoever for any dispute arising from the use of such technical information.

The Products specified in this document are intended to be used with general-use electronic equipment or devices (such as audio visual equipment, office-automation equipment, communication devices, electronic appliances and amusement devices).

The Products specified in this document are not designed to be radiation tolerant.

While ROHM always makes efforts to enhance the quality and reliability of its Products, a Product may fail or malfunction for a variety of reasons.

Please be sure to implement in your equipment using the Products safety measures to guard against the possibility of physical injury, fire or any other damage caused in the event of the failure of any Product, such as derating, redundancy, fire control and fail-safe designs. ROHM shall bear no responsibility whatsoever for your use of any Product outside of the prescribed scope or not in accordance with the instruction manual.

The Products are not designed or manufactured to be used with any equipment, device or system which requires an extremely high level of reliability the failure or malfunction of which may result in a direct threat to human life or create a risk of human injury (such as a medical instrument, transportation equipment, aerospace machinery, nuclear-reactor controller, fuel-controller or other safety device). ROHM shall bear no responsibility in any way for use of any of the Products for the above special purposes. If a Product is intended to be used for any such special purpose, please contact a ROHM sales representative before purchasing.

If you intend to export or ship overseas any Product or technology specified herein that may be controlled under the Foreign Exchange and the Foreign Trade Law, you will be required to obtain a license or permit under the Law.



Thank you for your accessing to ROHM product informations.
More detail product informations and catalogs are available, please contact us.

ROHM Customer Support System

<http://www.rohm.com/contact/>