

Dedicated automotive-grade processes utilized for ultra-high reliability



General Automotive

High Reliability Type



HVAC



Cluster/AC panel



Rain sensor



Mirror ECU



Body control



TPMS

IC Low offset and high voltage with low quiescent current

Voltage Tracker ICs

BD3925FP-C (TO252-5 package)
BD3925HFP-C (HRP5 package)

ROHM BD3925FP-C/HFP-C voltage tracker ICs feature a voltage resistance of 50V and an output current of 500mA. Circuit current is limited to 45μA, optimized to minimize current consumption of battery driver automotive systems, high precision is ensured due to an output offset voltage of ±15mV.



Di Ultra Low leakage current schottky barrier diodes

Ultra Low IR type

RB□□8 series

Integrated ultra low IR metal which prevent thermal runaway even under high temperature condition.

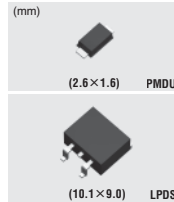

PM High reliability modules utilizing in-house components

Custom Power Modules

Power modules can be customized for any application.



IC Zero defect serial EEPROMs

High Reliability Serial EEPROMs

<H series for 125°C>

BR25H□□0 series (SPI BUS compatible, 6kV ESD resistance)
BR93H□□ series (Microwire BUS compatible, 8kV ESD resistance)
BR35H□□□ series (SPI BUS compatible, 6kV ESD resistance)

<A series for 105°C>

BR93A□□ series (Microwire BUS compatible)
BR24A□□ series (I²C BUS compatible)

A double-cell structure and double reset functionality, high ESD resistance, provide unprecedented reliability.



IC Operational amplifiers / comparators selectable according to applications and environment

Automotive Grade Operational Amplifiers/Comparators

<Ground sense op-amps>

BA2904Y series (with two circuits)
BA2902Y series (with four circuits)

<High-speed op-amps>

New BA3472Y series (with two circuits)
New BA3474Y series (with four circuits)

<Ground sense comparators>

BA2903Y series (with two circuits)
BA2901Y series (with four circuits)

ROHM's automotive-grade op-amps and comparators provide a maximum operating temperature of -40°C to +125°C and electrostatic breakdown voltage of 5kV. In addition, automotive-specific processes are utilized, ensuring stable operation – even under severe conditions.

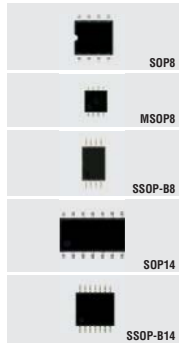

Standard Type



HVAC



Cluster/AC panel



Rain sensor



Mirror ECU



Body control



TPMS

IC High performance high reliability regulators

High Voltage LDO Regulators

BD357□FP (50V voltage resistance, I_o=500mA, TO252 package)
BD357□HFP (50V voltage resistance, I_o=500mA, HRP5 package)
BD3650FP-M (36V voltage resistance, I_o=300mA, TO252-3 package)

Low current consumption prolongs battery life

The BD357□FP and BD357□HFP series regulators provide a high voltage of 50V and 500mA output with quiescent circuit current of only 30μA. Optimized for battery driven applications.

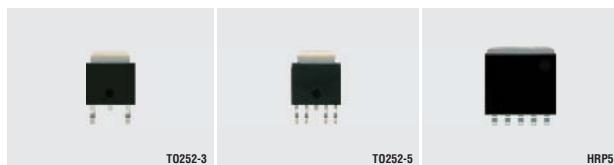
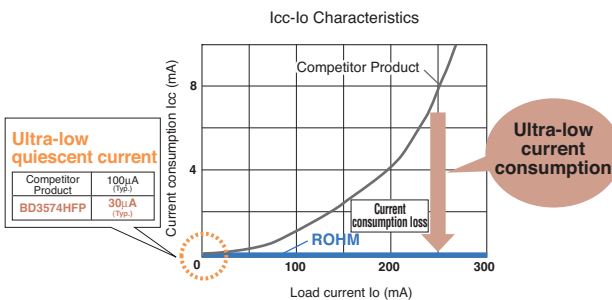

IC Provide high efficiency power from battery voltage

Flexible Step-down Switching Regulators with Built-in Power MOSFET

BD9001F (48V/2A type, SOP8 package)
BD9778F (35V/2A type, SOP8 package)
BD9778HFP (35V/2A type, HRP7 package)
BD9781HFP (35V/4A type, HRP7 package)

A high efficiency power MOSFET is built in, facilitating design while contributing to reduced system power consumption.



IC Ideal for greater system miniaturization and energy savings

Voltage Detector ICs with Watchdog Timer

BD37A□□FVM series (INH logic : H active)
BD87A□□FVM series (INH logic : L active)
BD99A41F (INH logic : H active)

Voltage detector ICs with watchdog timer are available in a number of configurations, including models with ON/OFF logic and different detection voltages.

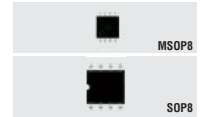

IC Watchdog timer and reset circuits built in for improved system reliability

Regulators with Voltage Detector and Watchdog Timer

☆ **BD3020HFP-M (Variable reset detection voltage + WDT ON/OFF function type, HRP7 package)**
BD3021HFP-M (WDT ON/OFF function type, HRP7 package)
BD3010AFV-M (Variable reset detection voltage + WDT ON/OFF function type, SSOP-B20 package)

These regulators with voltage detector and watchdog timer integrate a 5V regulator with watchdog timer reset functionality. High voltage of 50V is provided, improving system reliability.





Cluster/AC Panel

IC Direct Battery Drive

TFT Panel LED Backlight Drivers

- BD8112EFV-M (2ch, HTSSOP-B24 package)
- BD8119FM-M (4ch, HSOP-M28 package)
- ☆ BD81A04EFV-M (4ch, 2.2MHz Operation, HTSSOP-B28 package)
- ☆ BD81A04MUV-M (4ch, 2.2MHz Operation, VQFN028V5050 package)
- ☆ BD81A11EFV-M (1ch, 2.2MHz Operation, HTSSOP-B24 package)
- ☆ BD81A11MUV-M (1ch, 2.2MHz Operation, VQFN028V5050 package)

These high voltage LED drivers, making direct battery drive possible. In addition, an integrated boost/buck DC/DC converter ensures safe, stable operation – even during battery jitter/vibration. Multiple protection circuits, including LED open/short detection, are also built in, providing greater system reliability.

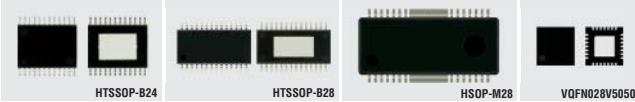

IC Ideal for Car Infotainment Panels

Graphics Display Controller for Instrument Panels

New ML511003 (QFP128 package)

This graphics display controller with integrated video functionality, is capable of synthesizing complicated graphics and video image, enables to display video from the rear-view camera simultaneously with informational graphics such as drive position and turn signals.

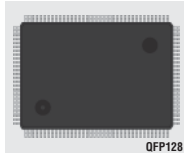

IC VFD/OLED Drivers Optimized for Multi-Colored Instrument and Accessory Displays

Instrument Panel/Display Drivers

- ML92□□[VFD] (QFP/SSOP package)
- ML93□□[OLED] (TCP/COG package)

These driver ICs for VFD and OLED displays in automotive systems are compatible with a variety of display formats (i.e. character type, dot matrix) and well as driver methods, including anode/cathode drive chipsets and one-chip display types.

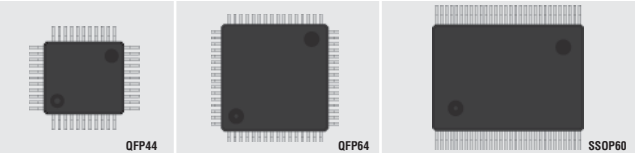

IC High quality imaging via video adjustment function

Display Controllers for Small to Medium-Sized TFT LCDs

- ML86V8202TB (TQFP100 package)
- ML86V8401TB (TQFP100 package)

Input analog video signal and digital video signal, scaling to display sizes and image adjustment make possible to display high quality images. Also, enable direct connection to various type of LCD panel with timing controller. On-screen display function, built-in MCU and etc. are also offered.

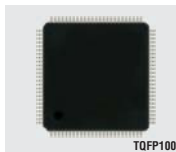

☆ : under development

IC High Performance Voice Synthesis IC for High Fidelity Automotive Interior Sound Generation

Voice ICs for Warning/Alarms

- ML22Q573 (Flash Type, SSOP30 package)
- ML22573 (Mask Type, SSOP30 package)

The ML22Q573 is a 4ch voice synthesis IC featuring a high-fidelity playback engine and speaker amp output. Operation is guaranteed up to +105°C, making it suitable for high temperature environments such as automotive instrument panels. Unlike competitor models that integrate speaker amps not even rated at +85°C, internal 1W speaker amp guarantees clear playback even under severe conditions. In addition, the 4ch mixing function makes it possible to enable alarm/warning sound generation (i.e. blinkers) - that previously were configured separately - into a single chip, eventually reduces system costs.

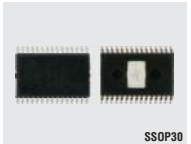

IC Market-approved Automotive-Grade 64Mbit SDRAM DRAM

MD56V62160E-10TAZP3 (TSOP(II)54 package)

The MD56V62160E-10TAZP3 high reliability SDRAM integrates 4x1Mx16bit memory banks. Stable operation is ensured throughout a wide temperature range. A quarter of a century of DRAM development and manufacturing provides the level of quality, traceability, and support required by automotive systems.



LED Colorful Instrumentation

Chip LEDs

<Ultra-Bright Chip LEDs>

SML-Z series (3.5x2.8mm, t=1.9mm)

High heat-resistant resin enables 50mA operation at +85°C.

Wide operating temperature range: -40°C to +110°C

<High-Bright Chip LEDs>

SML-512(A) series (1.6x0.8mm, t=0.55mm)

SML-212(A) series (2.0x1.25mm, t=0.8mm)

Designed for automotive applications.

<Reflector Chip LEDs>

SML-012(A) series (3.0x2.0mm, t=1.3mm)

Customizable colors.

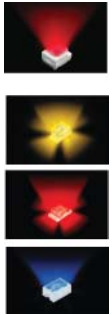

S Controller Rotation Detection

Compact Surface Mount Photointerrupters

RPI-0226V

A unique (bottom-protruding) structure is utilized for better mounting accuracy.



Rear Lamp/Stop Lamp

IC Low/High Current Switching

Rear-Lamp LED Source Driver ICs

New BD8372HFP-M (HRP7 package)

New BD8372EFJ-M (HTSOP-J8 package)

☆ BD8374HFP-M (Built-in PWM Dimming Functions, HRP7 package)

These high voltage (50V), high current (200mA), high accuracy (±3%) LED source drivers feature H/L constant current switching capability optimized for rear-lamp LED driver.

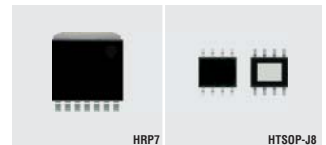

LED Automotive-Grade Reliability

Chip LEDs

☆ PLCC4 package

ROHM high reliability LEDs are ideal for stop and side lamps.



☆ : under development



Headlight/DRL

IC 1ch Boost/Buck LED Driver

LED Driver for Automotive Lamps

New BD8381EFV-M (Low Side Current Detection, Built-in PWM Control, HTSSOP-B28 package)

- ☆ BD8382EFV-M (Low Side Current Detection, HTSSOP-B24 package)
- ☆ BD8392EFV-M (High Side Current Detection, HTSSOP-B24 package)

High voltage (50V) LED driver integrates a step-up/down DC/DC driver for compatibility with a number of LED configurations. In addition, an internal PWM dimming circuit enables control without a microcontroller.

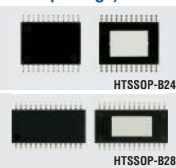

R High Power Chip Resistors<Wide Terminal Type>

Low Resistance series

LTR10 (0.5W)

☆ LTR18 (1W)

Enable replacement to one smaller size.



☆ : under development

Car electronics continues to evolve, providing greater safety and functionality. This entails increasingly sophisticated circuits. ROHM offer a broad lineup of products specifically developed for a number of automotive applications, including body, interface, security, AV, and sensor systems.



Body Control

Tf Industry-leading transistors

Solenoid Motor Drive Transistors

- DTDG14GP** ($V_{CC}=60\pm 10V$, $I_o=1A$, $R_1=None/R_2=10k\Omega$, MPT3 package)
- DTDG23YP** ($V_{CC}=60\pm 10V$, $I_o=1A$, $R_1=2.2k\Omega/R_2=10k\Omega$, MPT3 package)
- 2SD2143** ($V_{CE0}=60\pm 10V$, $I_c=2A$, $R_1=3.5k\Omega/R_2=0.3k\Omega$, Darlingtion, CPT3 package)
- QSH29** ($V_{CC}=60\pm 10V$, $I_o=0.5A$, $R_1=None/R_2=10k\Omega$, TSMT6 package : Dual)

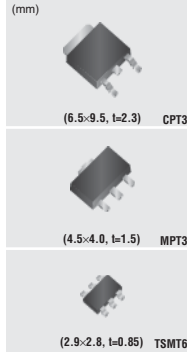
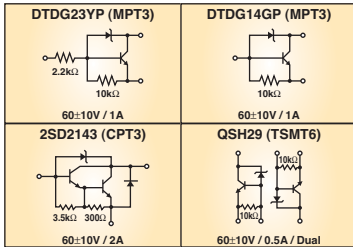

- Built-in protection clamp diode
- Space saving
- Less component counts

Di Market-approved reliability

Rectifier Diodes

- RRE02VS4S** ($V_{RM}=400V$, $I_o=0.2A$, TUMD2S package)
- RR264M-400** ($V_{RM}=400V$, $I_o=0.7A$, PMDU package)
- RR274EA-400** ($V_{RM}=400V$, $I_o=0.5A$, TSMD5 package)

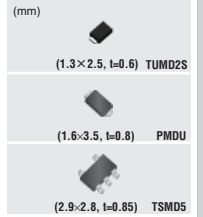

- 25% greater ESD resistance
- Resistant to both current and static voltage surges

R Automotive-grade reliability

Chip Resistors

<Anti-Surge>

- ESR series(1005 to 3225size)**
- Twice the rated power of conventional products
- Enables smaller resistors to be used

<Anti-Sulfuration>

- TRR series (1005 to 3216size)**
- Unique sulfuration-resistant layer utilized for superior anti-sulfuration characteristics

<High Power>

- LTR series(2012 to 5025size)**
- Wide terminal type

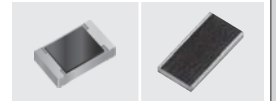

Camera Module / Network

IC Compact design compatible with the 3 major video formats

(NTSC, PAL, SECAM)

Video Decoder for Car Equipments

☆ **ML86V76654TB** (TQFP48 package)

This video decoder IC converts analog video signals to standard ITU-R BT.656. The 2D adaptive Y/C method cleanly separates the brightness and color signals in both the horizontal and vertical directions. A video decoder is required for processing analog signals, making it compatible with a wide variety of applications, from consumer electronics such as DVD recorders to rear-view monitors in vehicle systems.



Di Mounting area reduced by half*

Bi-directional Zener Diodes

*Compared to conventional diodes

- RSB16V** ($V_z=14.4$ to $17.6V$, UMD2 package)
- RSB18V** ($V_z=16.2$ to $19.8V$, UMD2 package)
- RSB27V** ($V_z=26.2$ to $32.0V$, UMD2 package)

Positive/negative surge protection on a single chip.
Optimized for CAN/LIN bus lines.



Tc Optimized for noise removal in supply lines

Tantalum Capacitors

Conductive Polymer Type : TCTO series

- M case (1608 size)** 22 μ F Max.
- P case (2012 size)** 68 μ F Max.
- A case (3216 size)** 220 μ F Max.

- Lower ESR by using conductive polymeric material
- Cutting down risks of emitting smoke and ignition
- Line-up from ESR35m Ω with small A case

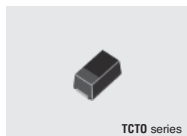

☆ : under development



Rain Sensor

Di Guaranteed surge protection in a compact form factor

Zener Diodes

KDZ series (PMDU package)

1W rated power in a compact size (2616).



ETC

IC RF and MODEM integrated into a single chip using CMOS technology

RFIC for ETCs/DSRCs

ML9636GDZB5A (WQFN48 package)

The ML9636GDZB5A is compatible with ARIB STD-T75 v1.4 for communication between vehicles (narrow-band communication standard). The combination RF/MODEM, developed using CMOS technology, facilitates connection with baseband ICs. The MODEM is compliant with ASK/QPSK. Supports backing, drivethrough, and DSRC-compatible ETC systems.



WQFN48





Mirror ECU

IC H-bridge 60V motor driver

2ch · 1ch 1A Output H-bridge Motor Driver

- New BD16925EFV-M (HTSSOP-B24 package)
- New BD16910EFV-M (HTSSOP-B20 package)

Conventional H-bridge circuits utilize a Darlington configuration comprised of bipolar transistors. In contrast, ROHM utilizes DMOSFETs with low ON-resistance for better efficiency and high voltage with less power loss and easy heat design.

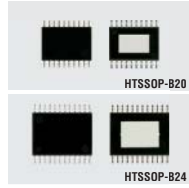

IC Ideal for automotive body and motor drive

Automotive Microcontrollers

- ☆ ML615Q297 (Flash : 64Kbyte, RAM : 4Kbyte, TQFP48 package)

Automotive-grade 8bit microcontrollers integrate Flash memory. Pipeline processing utilizing an original RISC CPU, along with hardware-based multiplication/division calculation, realizes high-speed processing equivalent to 16bit systems. Combine with ROHM's motor drivers to easily configure motor control circuits.



☆ : under development

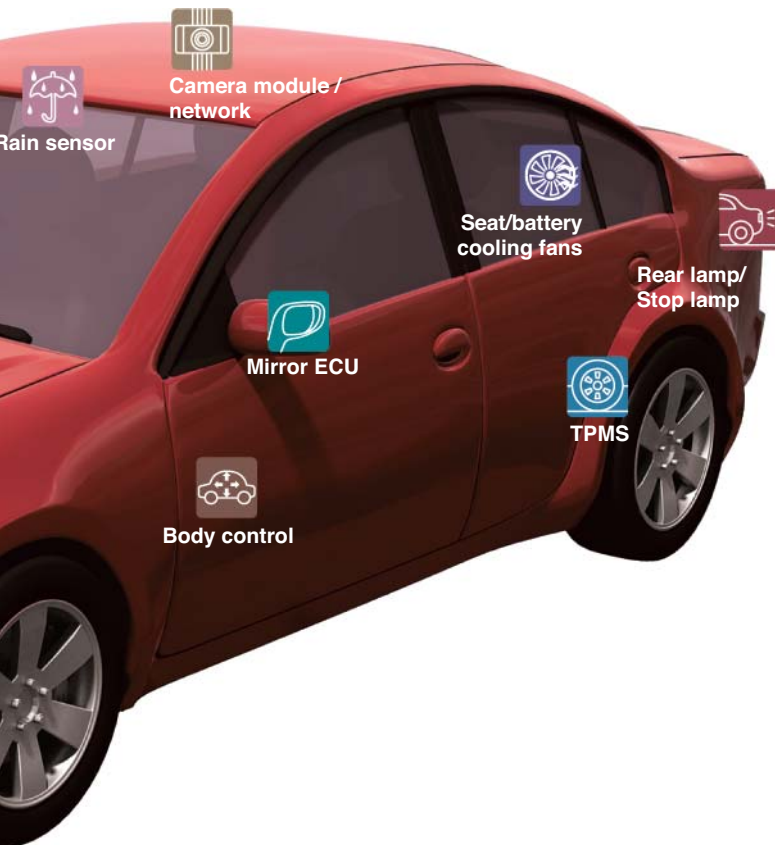

HVAC

IC H-bridge 60V motor driver

2ch · 1ch 1A Output H-bridge Motor Driver

- New BD16925EFV-M (HTSSOP-B24 package)
- New BD16910EFV-M (HTSSOP-B20 package)

Low ON-resistance DMOSFET built in for low current consumption and less power loss

Conventional H-bridge circuits utilize a Darlington configuration comprised of bipolar transistors. In contrast, ROHM utilizes DMOSFETs with low ON-resistance for better efficiency and high voltage with less power loss and easy heat design.

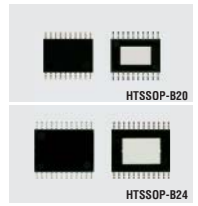
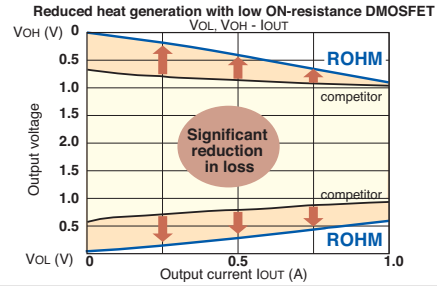

IC Ideal for automotive body and motor drive

Automotive Microcontrollers

- ☆ ML615Q297 (Flash : 64Kbyte, RAM : 4Kbyte, TQFP48 package)

Automotive-grade 8bit microcontrollers integrate Flash memory. Pipeline processing utilizing an original RISC CPU, along with hardware-based multiplication/division calculation, realizes high-speed processing equivalent to 16bit systems. Combine with ROHM's motor drivers to easily configure motor control circuits.



R Automotive-grade reliability

Chip Resistors

<Anti-Surge>

ESR series (1005 to 3225size)

- Twice the rated current of conventional products
- Enables smaller resistors to be used

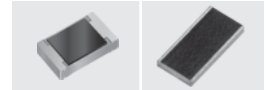

<High Power>

LTR series (2012 to 5025size)

- Wide terminal type

<Sulfuration-Resistant>

TRR series (1005 to 3216size)

- Original construction utilizing a sulfuration-resistant membrane results in superior anti-sulfuration characteristics

R Ideal for current detection

Low Ohmic Chip Resistors

PMR series (1608 to 6432size)

Line-up from 1mΩ.



PML series (2012 to 6432size)

High power due to wide terminal type.



UCR series (1005 to 3216size)

Available in a wide range of resistances (11mΩ to 910mΩ).

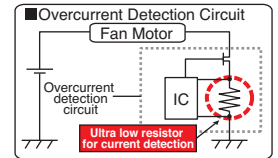

☆ : under development



Seat/Battery Cooling Fan Block

IC 60V 3-Phase Motor Driver

180° Energizing Pre-driver

- ☆ BD16805FV-M (SSOP-B40 package)

Unlike conventional 120° energizing, ROHM's 180° configuration ensures less noise for optimum motor drive operation. phase adjustment control technology contribute to higher efficiency and lower power consumption.

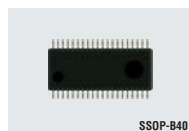

☆ : under development



HVAC/Blower Motor Block

IC 60V 3-Phase Motor Driver

180° Energizing Pre-driver

- ☆ BD16805FV-M (SSOP-B40 package)

Unlike conventional 120° energizing, ROHM's 180° configuration ensures less noise for optimum motor drive operation. phase adjustment control technology contribute to higher efficiency and lower power consumption.

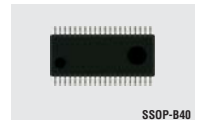

R Ultra low resistance for current detection

Low Ohmic Chip Resistors

PMR series (1608 to 6432size)

Avoiding thermal integration with trimming-less (function), reducing surface temperature increase.



☆ : under development

Contributing to more efficient driving

IC Product Specifications

General Automotive

Voltage Tracker ICs

Part No.	Offset Voltage (mV)	Output Current (A)	Maximum Voltage (V)	Circuit Current (μA)	Operating Temperature (°C)	Package
BD3925FP-C	±15 (Ta=-40 to +125°C, Vcc=6 to 36V, I _o =5 to 200mA)	0.5	50	45	-40 to +125	TO252-5
BD3925HFP-C	±15 (Ta=-40 to +125°C, Vcc=6 to 36V, I _o =5 to 200mA)	0.5	50	45	-40 to +125	HRP5

High Reliability Serial EEPROMs

Part No.	Density (bit)	Operating Voltage Range (V)	Operating Temperature (°C)	Lifetime (times)	Data Retention (yrs)	Package
BR25H□□0	1K to 32K	2.5 to 5.5	-40 to +125	10 ⁶	40	SOP8/SOP-J8/ TSSOP-B8
BR93H□□	2K to 16K	2.7 to 5.5	-40 to +125	10 ⁶	40	SOP8/SOP-J8/ TSSOP-B8/MSOP8
BR35H□□□	16K to 128K	2.5 to 5.5	-40 to +125	10 ⁶	40	SOP8/SOP-J8/ TSSOP-B8/MSOP8

Part No.	Density (bit)	Operating Voltage Range (V)	Operating Temperature (°C)	Lifetime (times)	Data Retention (yrs)	Package
BR93A□□	1K to 16K	2.5 to 5.5	-40 to +105	10 ⁶	40	SOP8/SOP-J8/ TSSOP-B8/MSOP8
BR24A□□	1K to 64K	2.5 to 5.5	-40 to +105	10 ⁶	40	SOP8/SOP-J8

High Voltage LDO Regulators

Part No.	Output Voltage (V)	Output Voltage Precision (%)	Output Current (A)	Maximum Voltage (V)	Circuit Current (μA)	No ON/OFF Function	Operating Temperature (°C)	Package
BD3570FP	3.3	±2 (Ta=-40 to +125°C)	0.5	50	30	No	-40 to +125	TO252-3
BD3570HFP	3.3	±2 (Ta=-40 to +125°C)	0.5	50	30	No	-40 to +125	HRP5
BD3571FP	5.0	±2 (Ta=-40 to +125°C)	0.5	50	30	No	-40 to +125	TO252-3
BD3571HFP	5.0	±2 (Ta=-40 to +125°C)	0.5	50	30	No	-40 to +125	HRP5
BD3572FP	Variable	±2 (Ta=-40 to +125°C)	0.5	50	30	No	-40 to +125	TO252-5
BD3572HFP	Variable	±2 (Ta=-40 to +125°C)	0.5	50	30	No	-40 to +125	HRP5
BD3573FP	3.3	±2 (Ta=-40 to +125°C)	0.5	50	30	Yes	-40 to +125	TO252-5
BD3573HFP	3.3	±2 (Ta=-40 to +125°C)	0.5	50	30	Yes	-40 to +125	HRP5
BD3574FP	5.0	±2 (Ta=-40 to +125°C)	0.5	50	30	Yes	-40 to +125	TO252-5
BD3574HFP	5.0	±2 (Ta=-40 to +125°C)	0.5	50	30	Yes	-40 to +125	HRP5
BD3575FP	Variable	±2 (Ta=-40 to +125°C)	0.5	50	30	Yes	-40 to +125	TO252-5
BD3575HFP	Variable	±2 (Ta=-40 to +125°C)	0.5	50	30	Yes	-40 to +125	HRP5
BD3650FP-M	5.0	±2 (Ta=-40 to +125°C)	0.3	36	500	No	-40 to +125	TO252-3

Flexible Step-Down Switching Regulators with Built-in Power MOSFET

Part No.	Supply Voltage (V)	Output Current (A)	Output Voltage (V)	Reference Voltage Accuracy (%)	Operating Temperature (°C)	Oscillation Circuit	Package
BD9001F	7 to 48	2.0	1 to VIN	±2	-40 to +95	Self-oscillation	SOP8
BD9778F	7 to 35	2.0	1 to VIN	±2	-40 to +125	Self-oscillation	SOP8
BD9778HFP	7 to 35	2.0	1 to VIN	±2	-40 to +125	Self-oscillation	HRP7
BD9781HFP	7 to 35	4.0	1 to VIN	±2	-40 to +125	Self-oscillation/ External synchronization	HRP7

Automotive Grade Operational Amplifiers/Comparators

Part No.	Number of Circuits	Supply Voltage (V)	Circuit Current (mA)	Input Offset Max. Voltage (mV)	Slew Rate (V/μs)	Gain Bandwidth (MHz)	Package
BA2904YF-C	2	3 to 32	0.7	±7	0.2	0.5	SOP8
BA2904YFV-C	2	3 to 32	0.7	±7	0.2	0.5	SSOP-B8
BA2904YFVM-C	2	3 to 32	0.7	±7	0.2	0.5	MSOP8
BA2902YF-C	4	3 to 32	0.7	±7	0.2	0.5	SOP14
BA2902YFV-C	4	3 to 32	0.7	±7	0.2	0.5	SSOP-B14

Part No.	Number of Circuits	Supply Voltage (V)	Circuit Current (mA)	Input Offset Max. Voltage (mV)	Slew Rate (V/μs)	Gain Bandwidth (MHz)	Package
BA3472YFV-C	2	3 to 36	4.0	±10	10	4	SSOP-B8
BA3472YFVM-C	2	3 to 36	4.0	±10	10	4	MSOP8
BA3474YFV-C	4	3 to 36	8.0	±10	10	4	SSOP-B14

Part No.	Number of Circuits	Supply Voltage (V)	Circuit Current (mA)	Input Offset Max. Voltage (mV)	Input Bias Current (nA)	Output Current (mA)	Input Voltage Range (V)	Package
BA2903YF-C	2	2 to 36	0.6	±5	50	16	V _{EE} to V _{CC} -1.5	SOP8
BA2903YFV-C	2	2 to 36	0.6	±5	50	16	V _{EE} to V _{CC} -1.5	SSOP-B8
BA2903YFVM-C	2	2 to 36	0.6	±5	50	16	V _{EE} to V _{CC} -1.5	MSOP8
BA2901YF-C	4	2 to 36	0.8	±5	50	16	V _{EE} to V _{CC} -1.5	SOP14
BA2901YFV-C	4	2 to 36	0.8	±5	50	16	V _{EE} to V _{CC} -1.5	SSOP-B14

Voltage Detector ICs with Watchdog Timer

Part No.	Output Voltage (V)	Output Voltage Precision (%)	Output Current (mA)	Reset Active Voltage Range (V)	WDT Active Voltage Range (V)	Circuit Current (μA)	Operating Temperature (°C)	Package
BD37A19FVM	1.9	±1.5 (Ta=25°C)	0.7	1.0 to 10	2.5 to 10	5	-40 to +105	MSOP8
BD37A41FVM	4.1	±1.5 (Ta=25°C)	0.7	1.0 to 10	2.5 to 10	5	-40 to +105	MSOP8
BD87A28FVM	2.8	±1.5 (Ta=25°C)	0.7	1.0 to 10	2.5 to 10	5	-40 to +105	MSOP8
BD87A29FVM	2.9	±1.5 (Ta=25°C)	0.7	1.0 to 10	2.5 to 10	5	-40 to +105	MSOP8
BD87A34FVM	3.4	±1.5 (Ta=25°C)	0.7	1.0 to 10	2.5 to 10	5	-40 to +105	MSOP8
BD87A41FVM	4.1	±1.5 (Ta=25°C)	0.7	1.0 to 10	2.5 to 10	5	-40 to +105	MSOP8
BD99A41F	4.1	±1.5 (Ta=25°C)	0.7	1.0 to 10	2.5 to 10	5	-40 to +105	SOP8

Regulators with Voltage Detector and Watchdog Timer

Part No.	Output Voltage (V)	Output Voltage Precision (%)	Output Current (mA)	Minimum IO Voltage Difference (mV)	Detection Voltage (V)	Reset Voltage Detector (V)	Function	Package
BD3020HFP-M	5	±2 (Ta=-40 to +125°C)	0.5	0.3 (I _o =200mA)	Variable (at V _{os} open: 4.1V)	±2	Adjustable Voltage Detector +WDT (Active switch)	HRP7
BD3021HFP-M	5	±2 (Ta=-40 to +125°C)	0.5	0.3 (I _o =200mA)	4.5	±2	4.5V Voltage Detector +WDT (Active switch)	HRP7
BD3010AFV-M	5	±2 (Ta=-40 to +125°C)	0.2	0.25 (I _o =150mA)	Variable (at R4D open: 4.25V)	±3	Adjustable Voltage Detector +WDT (Active switch)	SSOP-B20

Camera Module/Network

Video Decoder for Car Equipments

Part No.	Input Voltage (V)	Core	Operating Temperature (°C)	Package
☆ ML86V76654TB	3.3	1.5	-40 to +85	TQFP48

☆ : under development

ETC

RFIC for ETCs/DSRCs

Part No.	Power Supply (V)	Current Consumption (mA Max.)	Operating Temperature (°C)	Package
ML9636GDZB5A	3.3	37	-30 to +85	WQFN48

Mirror ECU

2ch•1ch 1A Output H-bridge Motor Driver

Part No.	CH	Maximum Voltage (V)	Maximum Output Current (A)	ON Resistance (Upper+Lower) (Ω)	Operating Temperature (°C)	Package
New BD16925EFV-M	2CH	60	1	2.25 (typ.)	-40 to +110	HTSSOP-B24
New BD16910EFV-M	1CH	60	1	2.25 (typ.)	-40 to +110	HTSSOP-B20

Automotive Microcontrollers

Part No.	Memory	Supply Voltage (V)	Operating Temperature (°C)	Package
☆ ML615Q297	Flash 64Kbyte, RAM 4Kbyte	V _{DD} 3.0 to 5.5, AV _{DD} 3.0 to 5.5	-40 to +105	TQFP48

☆ : under development

HVAC

2ch•1ch 1A Output H-bridge Motor Driver

Part No.	CH	Maximum Voltage (V)	Maximum Output Current (A)	ON Resistance (Upper+Lower) (Ω)	Operating Temperature (°C)	Package
New BD16925EFV-M	2CH	60	1	2.25 (typ.)	-40 to +110	HTSSOP-B24
New BD16910EFV-M	1CH	60	1	2.25 (typ.)	-40 to +110	HTSSOP-B20

Automotive Microcontrollers

Part No.	Memory	Supply Voltage (V)	Operating Temperature (°C)	Package
☆ ML615Q297	Flash 64Kbyte, RAM 4Kbyte	V _{DD} 3.0 to 5.5, AV _{DD} 3.0 to 5.5	-40 to +105	TQFP48

☆ : under development

Seat/Battery Cooling Fan Block

180° Energizing Pre-driver

Part No.	Maximum Voltage (V)	Output Type	Energizing	Phase Adjustment Control	Operating Temperature (°C)	Package
☆ BD16805FV-M	60	Pre-driver output	180°	Yes	-40 to +110	SSOP-B40

☆ : under development

Cluster/AC Panel

TFT Panel LED Backlight Drivers

Part No.	Power Supply (V)	Output Voltage (V)	Output Current (mA)	Switching Frequency (MHz)	Operating Temperature (°C)	Package
BD8112EFV-M	5.0 to 30	Max. 36	Max. 150/ ch	0.25 to 0.60	-40 to +105	HTSSOP-B24
BD8119FM-M	5.0 to 30	Max. 36	Max. 150/ ch	0.25 to 0.55	-40 to +95	HSOP-M28
☆ BD81A04EFV-M	4.5 to 35	Max. 40	Max. 120/ ch	0.2 to 2.20	-40 to +95	HTSSOP-B28
☆ BD81A04MUV-M	4.5 to 35	Max. 40	Max. 120/ ch	0.2 to 2.20	-40 to +95	VQFN028V050
☆ BD81A11EFV-M	4.5 to 35	Max. 40	Max. 400/ ch	0.2 to 2.20	-40 to +95	HTSSOP-B24
☆ BD81A11MUV-M	4.5 to 35	Max. 40	Max. 400/ ch	0.2 to 2.20	-40 to +95	VQFN028V050

☆ : under development

Graphics Display Controller for Instrument Panels

Part No.	Power Supply (V)	Core, PLL	Current Consumption (mA Max.)	Operating Temperature (°C)	Package
New ML511003	3.3	1.5	20	-40 to +85	QFP128

Instrument Panel/Display Drivers

Part No.	Power Supply (V)	Operating Temperature (°C)	No. of Channels	Package
ML92□□(VFD)	8 to 65(Drive Block)	-40 to +125	33 to 48	QFP/SSOP
ML93□□(OLED)	8 to 24(Drive Block)	-40 to +125	96 to 258(positive) Max. 64(negative)	TCP/COG

Voice ICs for Warning/Alarms

Part No.	Power Supply (V)	Operating Temperature (°C)	Speaker Amplifier	Voice Synthesis Method	Package
ML22Q573(Flash)	2.7 to 5.5	-40 to +105	1.0W@85°C, 5V, 8Ω	HQ-ADPCM 16bit linear PCM 8bit Non linear PCM	SSOP30
ML22573(Mask)	2.7 to 5.5	-40 to +105	1.0W@85°C, 5V, 8Ω	HQ-ADPCM 16bit linear PCM 8bit Non linear PCM	SSOP30

DRAM

Part No.	Power Supply (V)	Operating Temperature (°C)	Max. Operating Frequency (MHz)	Cycle Time (ns)	Package
MD56V62160E-10TAZP3	3.3±0.3	-40 to +85	100	10	TSOP(II)54

Display Controllers for Small to Medium-Sized TFT LCDs

Part No.	Power Supply (V)	Operating Temperature (°C)	Resolution	OSD	MCU	Package
ML86V8202TB	3.0 to 3.6	1.7 to 2.0	-40 to +85	QVGA to WVGA	-	TQFP100
ML86V8401TB	3.0 to 3.6	3.0 to 3.6	-40 to +85	QVGA to WVGA	Text	8051 (8bit) TQFP100

☆ : under development

Headlight/DRL

LED Driver for Automotive Lamps

Part No.	Power Supply (V)	Absolute Maximum Voltage(V)	Compatible Application	PWM Dimming Functions	LED Protection Functions	Current Detection	Package
BD8381EFV-M	5.0 to 30	50	Boost-Buck/Boost/Buck	○	LED open/short protection LED anode/cathode ground fault protection	Low Side	HTSSOP-B28
☆ BD8382EFV-M	5.0 to 30	50	Boost-Buck/Boost/Buck	×	LED open/short protection LED anode/cathode ground fault protection	Low Side	HTSSOP-B24
☆ BD8392EFV-M	5.0 to 30	40	Boost-Buck/Boost/Buck	×	LED open/short protection LED anode/cathode ground fault protection	High Side	HTSSOP-B24

☆ : under development

Rear Lamp/Stop Lamp

Rear-Lamp LED Source Driver ICs

Part No.	Power Supply (V)	Output Current (mA)	Output Current Accuracy (Ia=25°C)	Dimming Method	Maximum Voltage(V)	Package
BD8372HFP-M	5.5 to 40	200	±3%	H/L Current Switching	50	HRP7
BD8372EFJ-M	5.5 to 40	200	±3%	H/L Current Switching	50	HTSSOP-J8
☆ BD8374HFP-M	4.5 to 42	500	±3%	PWM Dimming	50	HRP7

☆ : under development

HVAC/Blower Motor Block

180° Energizing Pre-driver

Part No.	Maximum Voltage(V)	Output Type	Energizing	Phase adjustment control	Operating Temperature(°C)	Package
☆ BD16805FV-M	60	Pre-driver output	180°	Yes	-40 to +110	SSOP-B40

☆ : under development

Discrete Product Specifications

Body Control

Solenoid Motor Drive Transistors

Part No.	Polarity	V _{CE(VCEO)} (V)	I _O (A)	P _d (mW) (Ia=25°C)	G _I (hrs)	R1/R2 (kΩ)	Package
DTDG14GP	NPN	60±10	1	500	300 to	None/10	MPT3
DTDG23YP	NPN	60±10	1	500	300 to	2.2/10	MPT3
2SD2143	NPN	60±10	2	1000	1k to 10k	3.5/0.3	CPT3
QSH29	NPN+NPN	60±10	0.5	500	500 to	None/10	TSMT6

Rectifier Diodes

Part No.	V _{RM} (V)	I _O (A)	I _{FSM} (A)	Package
RRE02VS4S	400	0.2	1	TUMD2S
RR264M-400	400	0.7	25	PMDU
RR274EA-400	400	0.5	8	TSM5

Camera Module/Network

Bi-directional Zener Diodes

Part No.	P (mW)	V _{Z(V)} Max.		Package
		I _Z (mA)	I _Z (mA)	
RSB16V	200	14.4 to 17.6	1	UMD2
RSB18V	200	16.2 to 19.8	1	UMD2
RSB27V	200	26.2 to 32.0	1	UMD2

Cluster/AC Panel

- Voltage Tracker ICs
- Ultra Low IR Schottky Barrier Diodes
- High Reliability Serial EEPROMs
- Custom Power Modules
- High Voltage LDO Regulators
- Flexible Step-Down Switching Regulators with Built-In Power MOSFET
- Automotive Grade Operational Amplifiers/Comparators
- Regulators with Voltage Detector and Watchdog Timer
- Voltage Detector ICs with Watchdog Timer
- TFT Panel LED Backlight Drivers
- Graphics Display Controller for Instrument Panel
- Instrument Panel/Display Drivers
- Voice ICs for Warning/Alarms
- DRAM
- Chip LEDs
- Compact Surface Mount Photointerrupters
- Display Controllers for Small to Medium-Sized TFT LCDs

HVAC

- Voltage Tracker ICs
- Ultra Low IR Schottky Barrier Diodes
- High Reliability Serial EEPROMs
- Custom Power Modules
- High Voltage LDO Regulators
- Flexible Step-Down Switching Regulators with Built-In Power MOSFET
- Automotive Grade Operational Amplifiers/Comparators
- Regulators with Voltage Detector and Watchdog Timer
- Voltage Detector ICs with Watchdog Timer
- 2ch·1ch 1A Output H-bridge Motor Driver
- Automotive Microcontrollers
- Chip Resistors
- Low Ohmic Chip Resistors

Headlight/DRL

- LED Driver for Automotive Lamps
- Wide Terminal type / Low Resistance series

ETC

- RFIC for ETCs/DSRCs

Rain Sensor

- Voltage Tracker ICs
- Ultra Low IR Schottky Barrier Diodes
- High Reliability Serial EEPROMs
- Custom Power Module
- High Voltage LDO Regulators
- Flexible Step-Down Switching Regulators with Built-In Power MOSFET
- Automotive Grade Operational Amplifiers/Comparators
- Regulators with Voltage Detector and Watchdog Timer
- Voltage Detector ICs with Watchdog Timer
- Zener Diodes

Camera Module/Network

- Video Decoder for Car Equipments
- Bi-directional Zener Diodes
- Tantalum Capacitors

Seat/Battery Cooling Fan Block

- 180° Energizing Pre-driver

Rear Lamp/Stop Lamp

- Rear-Lamp LED Source Driver ICs
- Chip LEDs

TPMS

- Voltage Tracker ICs
- Ultra Low IR Schottky Barrier Diodes
- High Reliability Serial EEPROMs
- Custom Power Modules
- High Voltage LDO Regulators
- Flexible Step-Down Switching Regulators with Built-In Power MOSFET
- Automotive Grade Operational Amplifiers/Comparators
- Regulators with Voltage Detector and Watchdog Timer
- Voltage Detector ICs with Watchdog Timer

Mirror ECU

- Voltage Tracker ICs
- Ultra Low IR Schottky Barrier Diodes
- High Reliability Serial EEPROMs
- Custom Power Modules
- High Voltage LDO Regulators
- Flexible Step-Down Switching Regulators with Built-In Power MOSFET
- Automotive Grade Operational Amplifiers/Comparators
- Regulators with Voltage Detector and Watchdog Timer
- Voltage Detector ICs with Watchdog Timer
- 2ch·1ch 1A Output H-bridge Motor Driver
- Automotive Microcontroller

Body Control

- Voltage Tracker ICs
- Ultra Low IR Schottky Barrier Diodes
- High Reliability Serial EEPROMs
- Custom Power Modules
- High Voltage LDO Regulators
- Flexible Step-Down Switching Regulators with Built-In Power MOSFET
- Automotive Grade Operational Amplifiers/Comparators
- Regulators with Voltage Detector and Watchdog Timer
- Voltage Detector ICs with Watchdog Timer
- Solenoid Motor Drive Transistors
- Rectifier Diodes
- Chip Resistors

HVAC/Blower Motor Block

- 180° Energizing Pre-driver
- Low Ohmic Chip Resistors

General Automotive

- Voltage Tracker ICs
- Ultra Low IR Schottky Barrier Diodes
- Custom Power Modules
- High Reliability Serial EEPROMs
- Automotive Grade Operational Amplifiers/Comparators
- High Voltage LDO Regulators
- Flexible Step-Down Switching Regulators with Built-In Power MOSFET
- Voltage Detector ICs with Watchdog Timer
- Regulators with Voltage Detector and Watchdog Timer



HEV/EV Block

2,500Vrms galvanic isolation voltage

2,500Vrms Isolation

- ☆ **BM67220FV-C (SSOP-B20W package)**
- ☆ **BM67221FV-C (SSOP-B20W package)**

The BM67220FV-C and BM67221FV-C are isolators that integrate an isolated transformer chip. The units feature a maximum isolation voltage of 2,500Vrms and a maximum propagation delay of 50nsec for high-speed operation. Simply connection between the high and low voltage ECUs in HEVs and EVs ensuring stable, reliable, high-speed data transfer.



SSOP-B20W

Reduced mounting area of gate drive circuit

2,500Vrms isolated gate driver

- ☆ **BM6103FV-C (SSOP-B20W package)**
- ☆ **BM60011FV-C (SSOP-B20W package)**
- ☆ **BM60013FV-C (SSOP-B20W package)**

Compact package SSOP-B20W with gate drive / isolated function. Maximum output peak current is 5A, this enables downsizing mounting area of gate drive circuit.



SSOP-B20W

High accuracy temperature detection

IGBT Temperature Monitor

- ☆ **BD66000FV-CT (SSOP-B8 package)**

The BD66000FV-CT is designed to monitor the temperature of the IGBT in the inverter. Voltage from the diode within the IGBT is input, then converted to digital data (duty), before being output. Ideal for monitoring the temperature of the high voltage IGBT as well as transmitting Duty and Fail outputs to the low voltage ECU.



SSOP-B8

60V 3-Phase Motor Driver

180° Energizing Pre-driver

- ☆ **BD16805FV-M (SSOP-B40 package)**

Unlike conventional 120° energizing, ROHM's 180° configuration ensures less noise for optimum motor drive operation. phase adjustment control technology contribute to higher efficiency and lower power consumption.



SSOP-B40

Automotive battery monitor IC

Li-Ion Battery Monitor IC

- ☆ **ML5218 (TQFP64 package)**

The ML5218 was designed to monitor li-ion batteries in HEVs/EVs as well as electrical storage devices used in industrial and commercial applications. A high accuracy AD converter and reference power supply circuit are built in, enabling precise measurement of the li-ion battery voltage along with excessive charge/discharge conditions. Original 86.5V high voltage processes make it possible to handle up to 14 cells with one IC, also an IF is included for multistage connections. This enables the configuration of low-cost, high-voltage battery monitoring systems. In addition, market-approved automotive grade processes ensure a stable supply of high reliability ICs.



TQFP64

HEV System Diagram

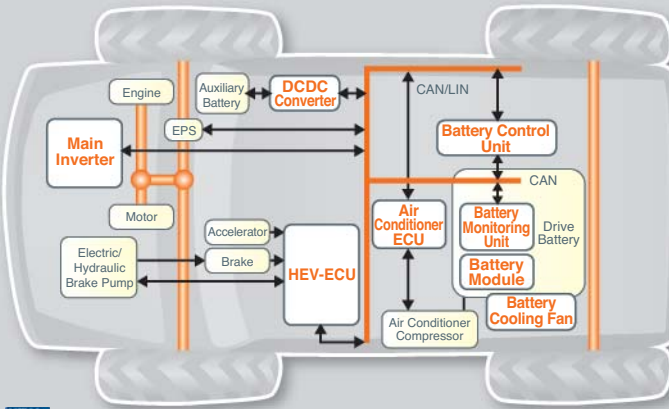

HEV/EV Block

- 2,500Vrms Isolation
- 2,500Vrms Isolated Gate Driver
- IGBT Temperature Monitor
- 180° Energizing 3-Phase Motor Pre-driver
- Li-Ion Battery Monitor IC

☆ : under development

2,500Vrms Isolation

Part No.	CH	CH Direction	Max. Propagation Delay Time (ns)	Isolation Voltage (Vrms)	Operating Voltage (V)	Operating Temperature(°C)	Package
☆ BM67220FV-C	2CH	Unidirectional (One-way)	50	2,500	4.5 to 5.5	-40 to +125	SSOP-B20W
☆ BM67221FV-C	2CH	Bidirectional (Two-way)	50	2,500	4.5 to 5.5	-40 to +125	SSOP-B20W

☆ : under development

2,500Vrms Isolated Gate Driver

Part No.	Operating voltage			Isolation Voltage (Vrms)	Maximum Output Peak Current (A)	Maximum Input/Output Delay Time(ns)	Package
	Low Voltage Range(V)	High Voltage Range Positive Power Supply (V)	High Voltage Range Negative Power Supply (V)				
☆ BM6103FV-C	4.5 to 5.5	14 to 24	-12 to 0	2,500	5	400	SSOP-B20W
☆ BM60011FV-C	4.5 to 5.5	12 to 24	-	2,500	5	320	SSOP-B20W
☆ BM60013FV-C	4.5 to 5.5	14 to 20	-	2,500	5	250	SSOP-B20W

☆ : under development

IGBT Temperature Monitor

Part No.	Duty Accuracy (%)	Detection Range(10% to 90%) (V)	Operating Voltage (V)	Operating Temperature(°C)	Package
☆ BD66000FV-CT	±2	0.69 to 1.49	4.5 to 5.5	-40 to +125	SSOP-B8

☆ : under development

180° Energizing 3-Phase Motor Pre-driver

Part No.	Maximum Voltage(V)	Output Type	Energizing	Phase Adjustment Control	Operating Temperature(°C)	Package
☆ BD16805FV-M	60	Pre-driver output	180°	Yes	-40 to +110	SSOP-B40

☆ : under development

Li-Ion Battery Monitor IC

Part No.	No. of Cells Supported	Maximum Voltage(V)	Supply Voltage (V)	Voltage Measurement Tolerance	Current Consumption While Operating	Current Consumption While Powered Down	Package
☆ ML5218	4 to 14	86.5	9.8 to 65.8	±10mV	2mA	15µA	TQFP64

☆ : under development

The content specified in this document is correct as of 1st. October, 2011.

No copying or reproduction of this document, in part or in whole, is permitted without the consent of ROHM Co.,Ltd.

The content specified herein is subject to change for improvement without notice.

The content specified herein is for the purpose of introducing ROHM's products (hereinafter "Products"). If you wish to use any such Product, please be sure to refer to the specifications, which can be obtained from ROHM upon request.

Examples of application circuits, circuit constants and any other information contained herein illustrate the standard usage and operations of the Products. The peripheral conditions must be taken into account when designing circuits for mass production.

Great care was taken in ensuring the accuracy of the information specified in this document. However, should you incur any damage arising from any inaccuracy or misprint of such information, ROHM shall bear no responsibility for such damage.

The technical information specified herein is intended only to show the typical functions of and examples of application circuits for the Products. ROHM does not grant you, explicitly or implicitly, any license to use or exercise intellectual property or other rights held by ROHM and other parties. ROHM shall bear no responsibility whatsoever for any dispute arising from the use of such technical information.

The Products specified in this document are intended to be used with general-use electronic equipment or devices (such as audio visual equipment, office-automation equipment, communication devices, electronic appliances and amusement devices).

The Products specified in this document are not designed to be radiation tolerant.

While ROHM always makes efforts to enhance the quality and reliability of its Products, a Product may fail or malfunction for a variety of reasons.

Please be sure to implement in your equipment using the Products safety measures to guard against the possibility of physical injury, fire or any other damage caused in the event of the failure of any Product, such as derating, redundancy, fire control and fail-safe designs. ROHM shall bear no responsibility whatsoever for your use of any Product outside of the prescribed scope or not in accordance with the instruction manual.

The Products are not designed or manufactured to be used with any equipment, device or system which requires an extremely high level of reliability the failure or malfunction of which may result in a direct threat to human life or create a risk of human injury (such as a medical instrument, transportation equipment, aerospace machinery, nuclear-reactor controller, fuel-controller or other safety device). ROHM shall bear no responsibility in any way for use of any of the Products for the above special purposes. If a Product is intended to be used for any such special purpose, please contact a ROHM sales representative before purchasing.

If you intend to export or ship overseas any Product or technology specified herein that may be controlled under the Foreign Exchange and the Foreign Trade Law, you will be required to obtain a license or permit under the Law.

ROHM Sales Offices

Contact us for further information about the products.

San Diego +1-858-625-3600	Mexico +52-33-3123-2001	Hungary +361-4719338	Philippines +63-2-807-6872
Atlanta +1-770-754-5972	Dusseldorf +49-2154-921-0	Russia +74 95 739 4174	Thailand +66-2-254-4890
Boston +1-978-371-0382	Stuttgart +49-711-7272370	Seoul +82-2-8182-700	Malaysia +60-3-7958-8355
Chicago +1-847-368-1006	France +33 (0) 1 40 60 87 30	Dalian +86-411-8230-8549	India +91-44-4352-0008
Dallas +1-972-473-3748	United Kingdom +44-1-908-272400	Shanghai +86-21-6279-2727	Kyoto +81-75-365-1218
Denver +1-303-708-0908	Espoo +358-9-7255-4491	Shenzhen +86-755-8307-3008	Yokohama +81-45-476-2121
Detroit +1-248-348-9920	Salo +358-2-7332234	Hong Kong +852-2-740-6262	
Nashville +1-615-620-6700	Oulu +358-400-726 124	Taiwan +886-2-2500-6956	
Sunnyvale +1-408-720-1900	Spain +34-9375-24320	Singapore +65-6332-2322	

Catalog No. 54A6504E 10.2011 ROHM © PDF

R1081B

ROHM Co.,Ltd.

21 Salin Mizosaki-cho, Ukyo-ku,
Kyoto 615-8585 Japan
TEL : +81-75-311-2121 FAX : +81-75-315-0172

www.rohm.com

