



Low Voltage (Single-cell battery) Operating Headphone Amplifier BU7150NUV

●Outline

BU7150NUV is Headphone Amplifier designed for Single-cell battery operated audio products (VDD = 0.93 to 3.5V, at Ta=0°C). BU7150NUV can be selected in single-ended mode for stereo headphone and BTL mode for mono speaker operations. For BU7150NUV at VDD = 1.5V, THD+N = 1%, the output power is 14mW at RL = 16Ω in single-ended mode and the output power is 85mW at RL = 8Ω in BTL mode.

●Features

- 1) Wide battery operating voltage range (0.93V to 3.5V, Ta=0 to 85°C) (1.03V to 3.5V, Ta= -40 to 85°C)
- 2) BU7150NUV can be selected in single-ended mode for stereo headphone and BTL mode for mono speaker operation
- 3) Unity-gain stability
- 4) Click and pop-noise reduction circuit built-in
- 5) Shutdown mode(Low power mode)
- 6) High speed turn-on mute mode
- 7) Thermal shutdown protection circuit
- 8) Power-on reset circuit not sensed during start-up slew rate of supply voltage
- 9) Small package (VSON010V3030)

●Applications

Noise-canceling headphones, IC recorders, Mobile phones, PDAs, Electronic toys etc.

●Absolute Maximum Ratings (Ta=25°C)

Parameter	Symbol	Rating	Unit
Supply Voltage	VDD	4.5	V
Input Voltage	VIN	VSS-0.3 to VDD+0.3	V
Input Current	IIN	-10 to 10	mA
Power Dissipation	PD	560 *	mW
Storage Temperature Range	TSTG	-55 to +150	°C

*For operating over 25°C, de-rate the value at 5.6mW/°C.

This value is for IC mounted on 74.2 mm x 74.2mm x 1.6mm glass-epoxy PCB of single-layer.

●Recommended Operating Range

Parameter	Symbol	Limit			Unit
		Min.	Typ.	Max.	
Operating Temperature Range	TOPR	-40	-	85	°C
Supply Voltage (Note 1,2)	VDD	0.93	-	3.5	V

Note 1: If the supply voltage is 0.93V, BU7150NUV does not function at less than 0°C.

If the supply voltage is more than 1.03V, BU7150NUV operates until -40°C.

(But, it is not the one which guarantees the standard value for electric characteristics.)

Note 2: Ripple in power supply line should not exceed 400mV_{P-P}.(VDD=1.5 V, Ta=25°C)

●Dimensions (Unit: mm)

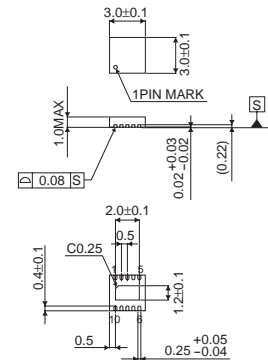

VSON010V3030

●Electrical Characteristics (Ta=25°C, VDD=1.5V, f=1kHz, VSS=GND unless otherwise specified)

Parameter	Symbol	Limit			Unit	Conditions
		Min.	Typ.	Max.		
No Signal Operating Current	IDD	-	1	1.4	mA	No load, No signal
Shutdown Current	ISD	-	3	9	μA	SDB Pin=VSS
Mute Current	IMUTE	-	15	-	μA	MUTEB Pin=VSS, SE
Output Offset Voltage	VOFS	-	5	50	mV	VOUT1 - VOUT2 , No signal
Maximum Output Power	PO	70	85	-	mW	RL=8Ω, BTL, THD+N=1%
		-	14	-	mW	RL=16Ω, SE, THD+N=1%
Total Harmonic Distortion +Noise	THD+N	-	0.2	0.5	%	20kHz LPF, RL=8Ω, BTL, PO=25mW
		-	0.1	0.5	%	20kHz LPF, RL=16Ω, SE, PO=5mW
Output Voltage Noise	VNO	-	10	-	μV _{rms}	20kHz LPF + A-weight
Crosstalk	CT	-	85	-	dB	RL=16Ω, SE, 1kHz BPF
Power Supply Rejection Ratio	PSRR	-	62	-	dB	Ripple voltage=200mV _{P-P} , RL=8Ω, BTL, C _{BYPASS} =4.7μF
		-	66	-	dB	Ripple voltage=200mV _{P-P} , RL=16Ω, SE, C _{BYPASS} =4.7μF
Input Logic High Level	VIH	0.7	-	-	V	MUTEB Pin, SDB Pin
Input Logic Low Level	VIL	-	-	0.3	V	MUTEB Pin, SDB Pin

“BTL” is BTL-mode when MODE Pin = VDD, “SE” is single-ended mode when MODE Pin = VSS.

Turn-on time in BTL mode is about 11 times faster than single-ended mode.

Also, BTL mode does not have MUTE mode. When MUTEB Pin = VSS, then will be shutdown mode.

●Block diagram(Single-ended mode application circuit)

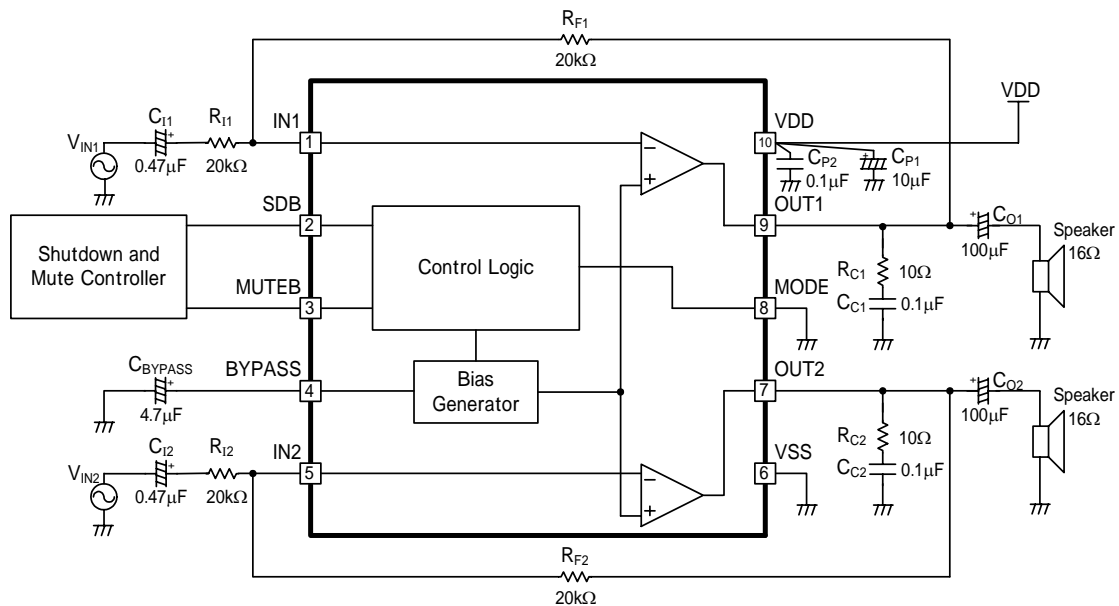

- Resistors R_{F1} , R_{F2} should be used in 20kΩ to 1MΩ range.
- For gain setting greater than 4 times, then R_{C1} , R_{C2} , C_{C1} , C_{C2} can be eliminated.

10077EAW12

The content specified herein is for the purpose of introducing ROHM's products (hereinafter "Products"). If you wish to use any such Product, please be sure to refer to the specifications, which can be obtained from ROHM upon request. Great care was taken in ensuring the accuracy of the information specified in this document. However, should you incur any damage arising from any inaccuracy or misprint of such information, ROHM shall bear no responsibility for such damage. The technical information specified herein is intended only to show the typical functions of and examples of application circuits for the Products. ROHM does not grant you, explicitly or implicitly, any license to use or exercise intellectual property or other rights held by ROHM and other parties. ROHM shall bear no responsibility whatsoever for any dispute arising from the use of such technical information. If you intend to export or ship overseas any Product or technology specified herein that may be controlled under the Foreign Exchange and the Foreign Trade Law, you will be required to obtain a license or permit under the Law.

The content specified in this document is correct as of 15. January, 2010.

ROHM Co., Ltd.

21 Saini Mizosaki-cho, Ukyo-ku,
Kyoto 615-8585 Japan
TEL : +81-75-311-2121
FAX : +81-75-315-0172
www.rohm.com

