

# Digital Ambient Light Sensor IC Compatible with I<sup>2</sup>C Bus Hs Mode

## BH1780GLI

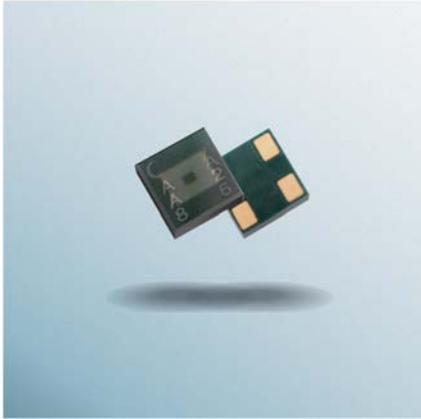

The world's first\* ambient light sensor IC developed for mobile phones compatible with I<sup>2</sup>C bus Hs mode

**Product outline**

ROHM's new ambient light sensor IC features a wide measurement range (from darkness to direct sunlight) and spectral sensitivity close to the human eye, while compatibility with I<sup>2</sup>C bus Hs (High speed) mode - an industry first - enables faster communication with the CPU while simplifying control and bus line layout. In addition, the new WLGA04IW02 package prevents malfunctions due to infrared light and original photo IC and trimming technologies are utilized to limit sensitivity variations to within +/-20%.

\*ROHM Sept. 2009 Survey

### ■ Hs Mode Compatibility - An Industry First\*

Compatibility with the new I<sup>2</sup>C bus Hs mode increases throughput to upto 3.4Mbps.

### ■ Optimized spectral sensitivity

The optical filter mold resin, developed utilizing original technology, results in spectral sensitivity characteristics close to the human eye. This minimizes dependence on light source for more stable, accurate measurements.

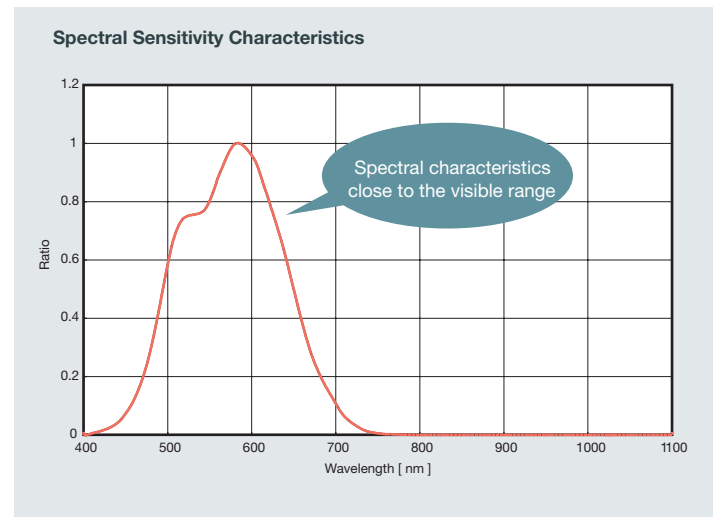
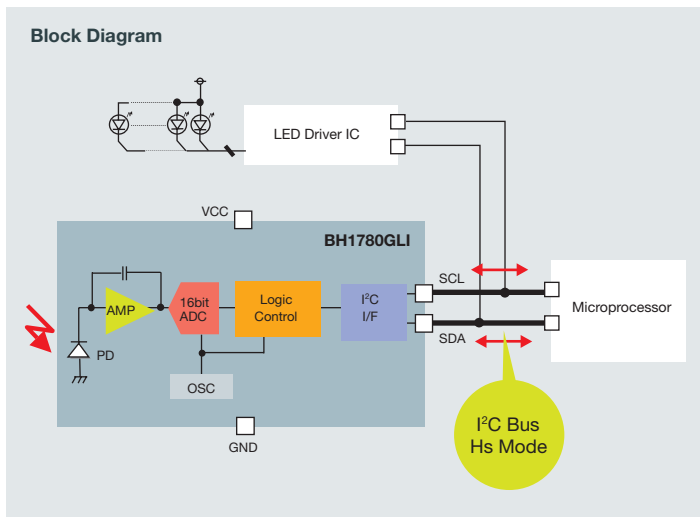

- Compatible with both Hs and f/s modes for I<sup>2</sup>C bus
- Wide light measurement range (0 to 65,535 lx)
- Built-in 16bit A/D converter eliminates the need for external parts
- Brightness value output digitally
- 50Hz/60Hz optical noise removal function ensures stable measurement

**Specifications**

Part No.	Supply Voltage (V)	Output Method	Sensitivity Variation (%)	Light Measurement Range (lx)
BH1780GLI	2.3 to 3.0	I <sup>2</sup> C I/F	±20	0 - 65,000

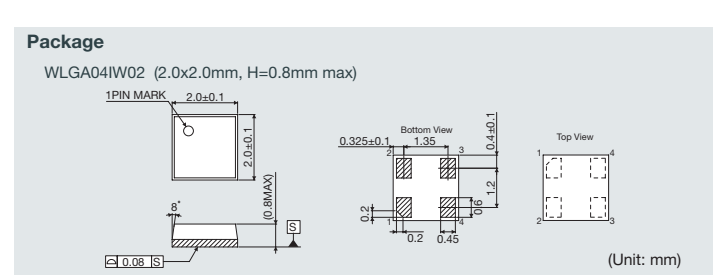

The content specified herein is for the purpose of introducing ROHM's products (hereinafter "Products"). If you wish to use any such Product, please be sure to refer to the specifications, which can be obtained from ROHM upon request. Great care was taken in ensuring the accuracy of the information specified in this document. However, should you incur any damage arising from any inaccuracy or misprint of such information, ROHM shall bear no responsibility for such damage. The technical information specified herein is intended only to show the typical functions of and examples of application circuits for the Products. ROHM does not grant you, explicitly or implicitly, any license to use or exercise intellectual property or other rights held by ROHM and other parties. ROHM shall bear no responsibility whatsoever for any dispute arising from the use of such technical information. If you intend to export or ship overseas any Product or technology specified herein that may be controlled under the Foreign Exchange and the Foreign Trade Law, you will be required to obtain a license or permit under the Law. The content specified in this document is correct as of 3rd September, 2009.