

2010

Product Catalog

**ROHM**  
SEMICONDUCTOR

Passive Components

# Tantalum Capacitors

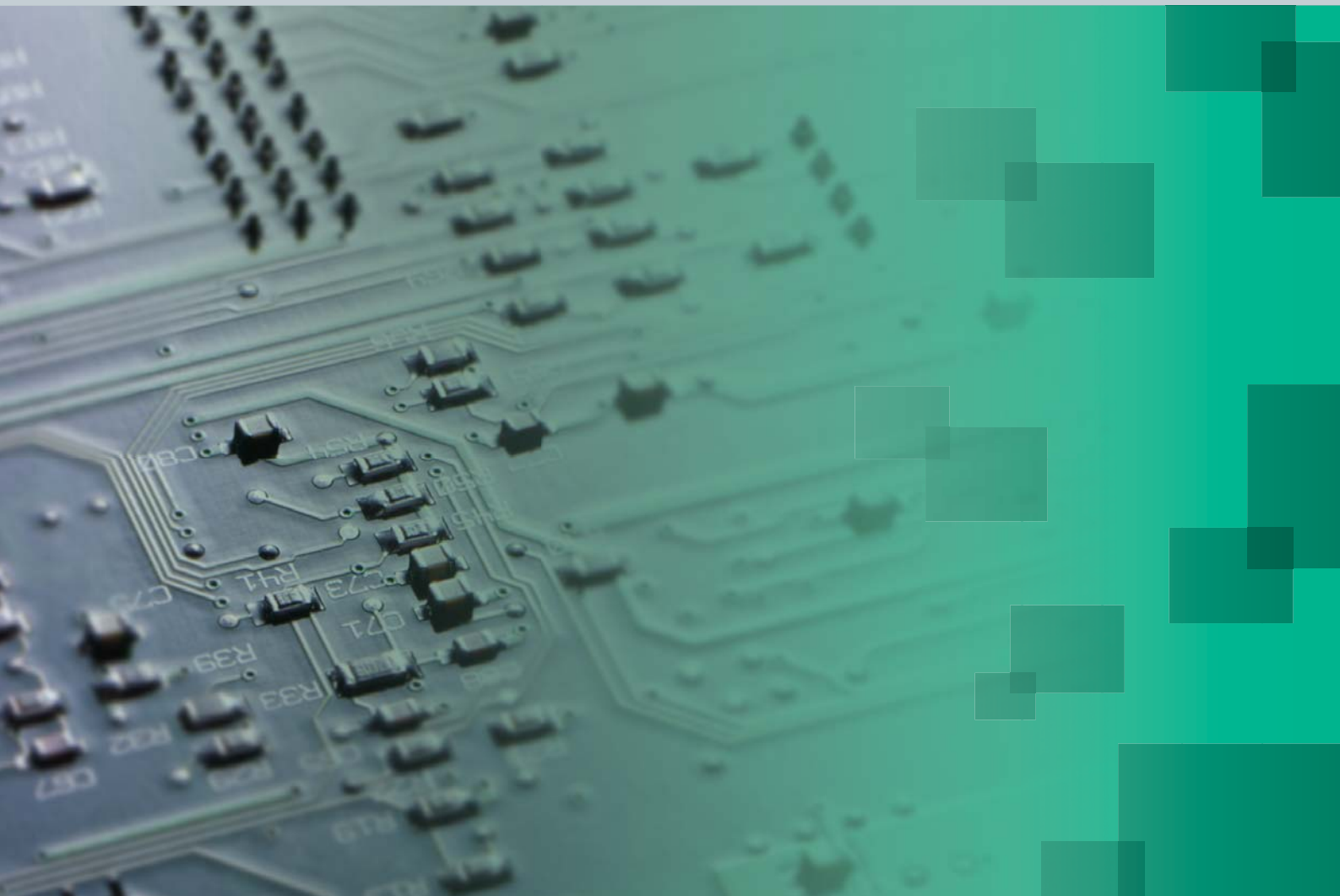

# Tantalum Capacitors

Tantalum capacitors offer several advantages over conventional multi-layer ceramic chip capacitors, such as larger capacitance in a more compact form factor and superior temperature and DC bias characteristics.

ROHM's broad lineup of tantalum capacitors include models that utilize a bottom electrode configuration, low ESR conductive polymer types, units with an open structure to prevent combustion and damage to peripheral components, and standard products featuring excellent mountability and reliability.

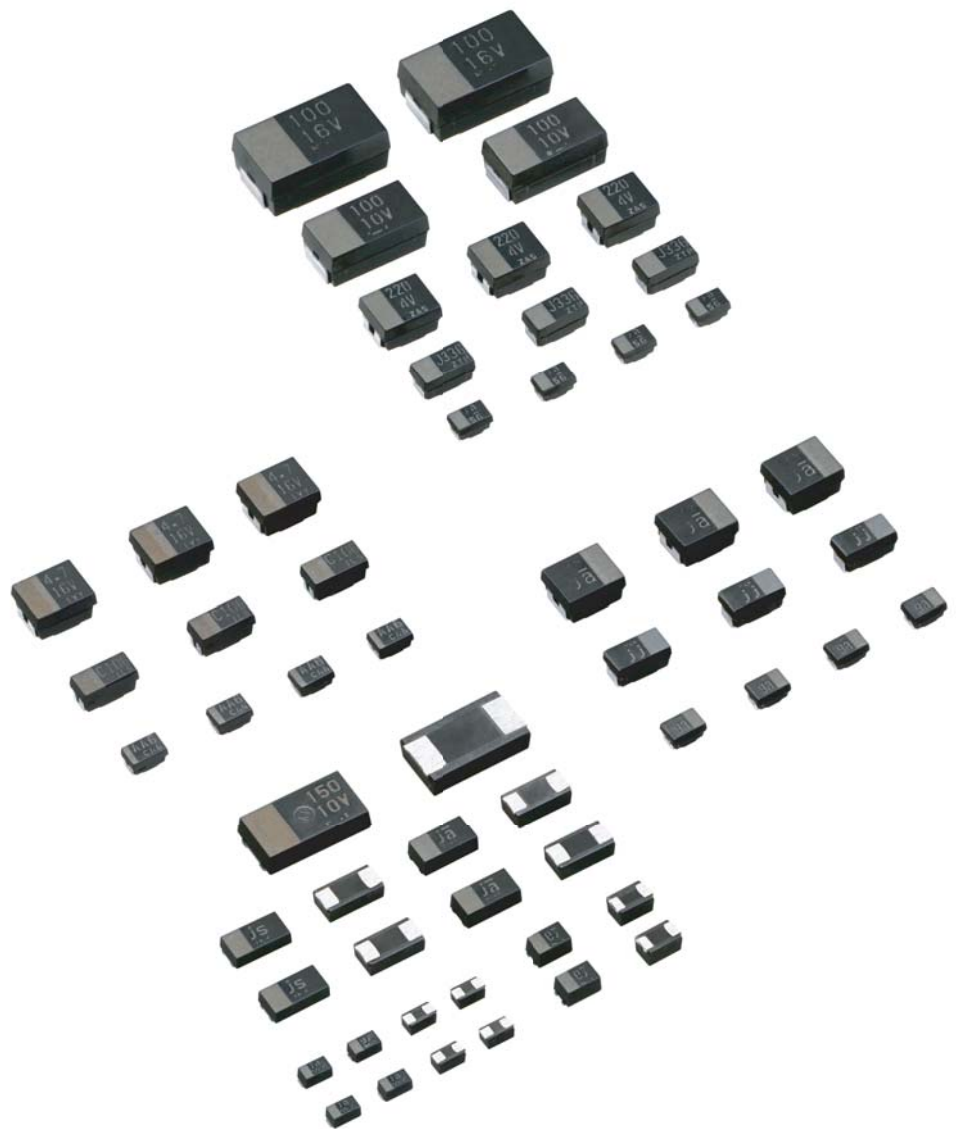

## Contents

---

TCS Seires : Bottom surface electrode large capacitance type	3
TCT Seires : Bottom surface electrode type	4
TCFG Seires : Fail-safe open structure type	6
TC Seires : Standard Type	8
TCTO Seires : Conductive polymer bottom surface electrode type	9
TCO Seires : Conductive polymer type	10
Recommended soldering conditions	11
Part Number explanation	13
Taping specifications	13
User precautions	14

# Bottom surface electrode large capacitance type

## TCS Series



### Summary

The TCT series employs a high efficiency package design for greater compactness and a lower profile with ultra-high capacitance.

### Features

- Thin
- Compact
- Ultra-high capacitance

### Applications

Mobile phones, digital cameras, digital camcorders, portable music players, and other thin, compact electronic devices

## New package construction features smaller, thinner form factor with larger capacitance

The unique package construction allows to put a larger tantalum element than conventional bottom electrode types (TCT Series), resulting in approximately twice the capacitance.

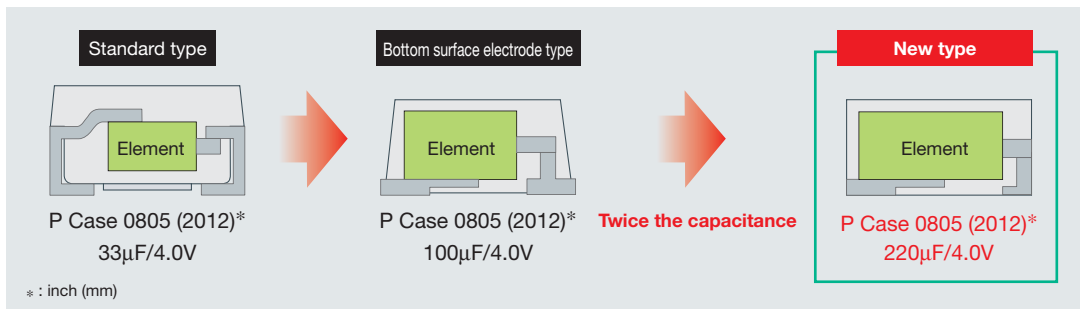

### Lineup

Capacitance code	Capacitance (µF)	Rated voltage(V, DC) / voltage code					
		2.5 e	4 g	6.3 j	10 A	16 C	20 D
a	10 (106)						P
e	15 (156)						
j	22 (226)					P	
n	33 (336)						
s	47 (476)				P		
w	68 (686)						
ā	100 (107)			P			
ē	150 (157)						
ī	220 (227)		P				
ñ	330 (337)	P					

RED : Under development

### Quick Reference

TCS Series P Case (2021)

Rated Voltage (V)	Capacitance (µF)	tanδ at 120Hz(25°C) (%)	Leakage current (25°C, 5min) (µA)	Impedance (at 100kHz) (Ω)	Part No.
2.5	330	40	83	3	TCSP0E337□
4	220	40	88	3	TCSP0G227□
6.3	100	40	63	3	TCSP0J107□
10	47	30	24	4	TCSP1A476□
16	22	30	18	4	TCSP1C226□
20	10	20	10	6	TCSP1D106□

□=Capacitance tolerance (M:±20%)

### Dimensions

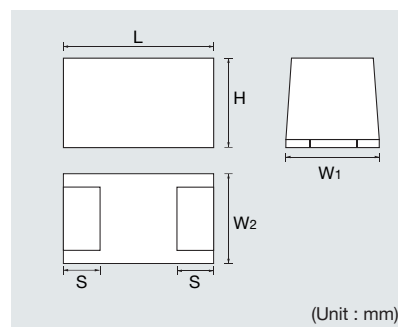

Case	L	W1	W2	H	S
P (2012-12[0805])	2.0±0.2	1.25±0.2	0.85±0.2	1.2 Max.	0.5±0.1

(Unit : mm)

# Bottom surface electrode type

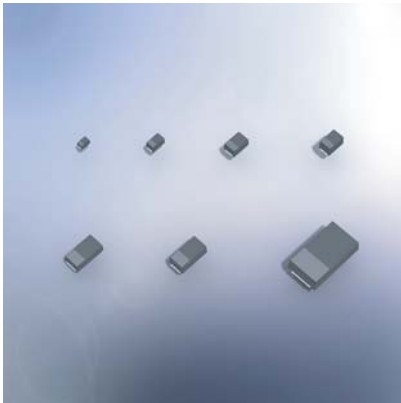

## TCT Series

\*The TC Series uses M cases exclusively.

### Summary

The compact terminal construction enables significantly higher capacitances than conventional types.

### Features

- Thin
- Compact
- High capacitance
- Low ESR

### Applications

Mobile phones, digital cameras, digital camcorders, portable music players, and other thin, compact electronic devices

## Compact · Low Profile · Large Capacitance

The compact terminal construction makes it possible to use a larger tantalum element, resulting in significantly higher capacitances than conventional units in the same size. In addition, the contact area between the element and terminal is larger, reducing ESR.

A broad lineup is available in a range of package types, from the ultra-compact U Case (0402\* size) to the 2412\*-sized CL Case.

\* : inch

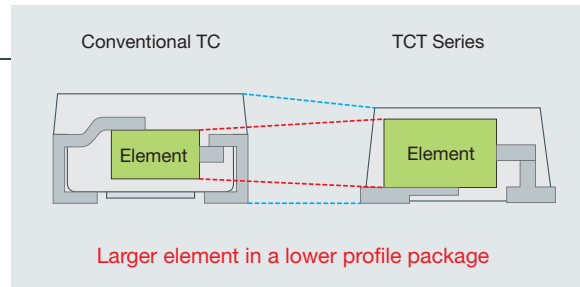

### Lineup

The use of the bottom surface electrode construction results in a relatively large amount of capacitance in every package size, ensuring that they are among the best in the industry.

RED : Under development

Capacitance code	Capacitance (μF)	Rated voltage (V, DC) / voltage code								
		2.5 e	4 g	6.3 j	10 A	16 C	20 D	25 E	35 V	
A	1.0 (105)			U	M	U M				PL P AS AL
E	1.5 (155)				U			PL		P AS AL
J	2.2 (225)			U	U M	M		PL P AS		AL
N	3.3 (335)				U			PL P	P AS	AL
S	4.7 (475)		U M	U M	U M		P	PL P	AS AL	
W	6.8 (685)		U	U			P	PL AS	AL	
a	10 (106)		U M	M	M		PL P	AS AL		
e	15 (156)	U				PL P	AS AL		AL	
j	22 (226)		M	M P	PL P		AS AL			
n	33 (336)		M P	PL P	PL P AS AL					
s	47 (476)	M	PL P	PL P AS	AS AL					
w	68 (686)	PL	PL P	PL P AS AL	AL					
ā	100 (107)	PL P	PL P AS AL	AS AL	AL		CL			
ē	150 (157)	PL P	P AS AL	AL		CL				
ī	220 (227)	P AS AL	AS AL		CL					
ñ	330 (337)	AL	CL							
š	470 (477)	CL								

### Dimensions

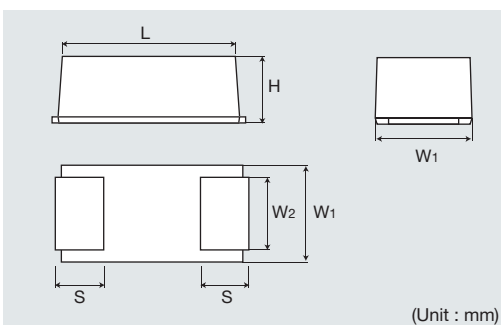

Case	L	W <sub>1</sub>	W <sub>2</sub>	H	S
U (1005-06[0402])	1.0 <sup>+0.2</sup> <sub>-0</sub>	0.5 <sup>+0.2</sup> <sub>-0</sub>	0.35±0.1	0.60 Max.	0.35±0.1
M (1608-09[0603])	1.6±0.1	0.85±0.1	0.55±0.1	0.8±0.1	0.5±0.1
PL (2012-10[0805] Low profile)	2.0±0.2	1.25±0.2	0.85±0.2	0.9±0.1	0.5±0.1
P (2012-12[0805])	2.0±0.2	1.25±0.2	0.85±0.2	1.1±0.1	0.5±0.1
AS (3216-10[1206] Ultra low profile)	3.2±0.2	1.6±0.2	1.2±0.2	0.9±0.1	0.8±0.2
AL (3216-12[1206] Low profile)	3.2±0.2	1.6±0.2	1.2±0.2	1.1±0.1	0.8±0.2
CL (6032-15[2412] Low profile)	6.0±0.2	3.2±0.2	2.2±0.2	1.4±0.1	1.3±0.2

(Unit : mm)

## Quick Reference

TCT series : U case (1005-05[0402] size)

Rated voltage (V)	Capacitance (μF)	tan at 120Hz(25°C) (%)	Leakage current (25°C, 5min) (μA)	Impedance (at 100kHz) (Ω)	Part No.
4	4.7	20	1.9	20	TCTU0G475□
6.3	1.0	20	0.7	20	TCTU0J105□
6.3	2.2	20	1.4	20	TCTU0J225□

□=Capacitance tolerance (M:±20%)

TC series : M case (1608-09[0603] size)

Rated voltage (V)	Capacitance (μF)	tan at 120Hz(25°C) (%)	Leakage current (25°C, 5min) (μA)	Impedance (at 100kHz) (Ω)	Part No.
4	4.7	20	0.5	9.0	TCM0G475□
	10	20	0.5	9.0	TCM0G106□
	22	20	0.9	9.0	TCM0G226□
6.3	33	30	13.0	9.0	TCM0G336□
	4.7	20	0.5	9.0	TCM0J475□
10	10	20	0.6	9.0	TCM0J106□
	1.0	10	0.5	15.0	TCM1A105□
	2.2	20	0.5	13.5	TCM1A225□
16	4.7	20	0.5	9.0	TCM1A475□
	10	20	10.0	9.0	TCM1A106□
	1.0	10	0.5	15.0	TCM1C105□
2.2	20	0.5	13.5	TCM1C225□	

□=Capacitance tolerance (M:±20%)

TCT series : PL case (2012-10[0805] Low profile size)

Rated voltage (V)	Capacitance (μF)	tan at 120Hz(25°C) (%)	Leakage current (25°C, 5min) (μA)	Impedance (at 100kHz) (Ω)	Part No.
4	47	20	9.4	4.0	TCTPLOG476□
	68	30	13.6	4.0	TCTPLOG686□
	100	30	20.0	4.0	TCTPLOG107□
6.3	47	30	14.8	4.0	TCTPLOJ476□

□=Capacitance tolerance (M:±20%)

TCT series : P case (2012-12[0805] size)

Rated voltage (V)	Capacitance (μF)	tanδ at 120Hz(25°C) (%)	Leakage current (25°C, 5min) (μA)	Impedance (at 100kHz) (Ω)	Part No.
2.5	100	30	12.5	4.0	TCTP0E107□
4	33	20	1.3	4.0	TCTP0G336□
	47	20	1.9	4.0	TCTP0G476□
	68	30	13.6	4.0	TCTP0G686□
	100	30	20.0	4.0	TCTP0G107□
6.3	22	20	1.4	5.0	TCTP0J226□
	33	20	2.1	4.0	TCTP0J336□
	47	30	14.8	4.0	TCTP0J476□
10	15	20	1.5	6.0	TCTP1A156□
	22	20	2.2	5.0	TCTP1A226□
	33	30	16.5	4.0	TCTP1A336□
16	10	20	1.6	6.0	TCTP1C106□
25	2.2	20	0.55	8.0	TCTP1E225□

□=Capacitance tolerance (M:±20%)

TCT series : AS case (3216-10[1206] Low profile size)

Rated voltage (V)	Capacitance (μF)	tan at 120Hz(25°C) (%)	Leakage current (25°C, 5min) (μA)	Impedance (at 100kHz) (Ω)	Part No.
4	100	20	20.0	3.0	TCTAS0G107□
	47	20	6.0	4.0	TCTAS0J476□
6.3	68	20	21.5	4.0	TCTAS0J686□
	33	15	6.6	4.0	TCTAS1A336□
10	47	20	9.4	4.0	TCTAS1A476□
	15	15	4.8	4.0	TCTAS1A156□
16	22	20	7.1	4.0	TCTAS1C226□
	10	15	4.0	4.0	TCTAS1D106□

□=Capacitance tolerance (M:±20%)

TCT series : AL case (3216-12-[1206] Low profile size)

Rated voltage (V)	Capacitance (μF)	tan at 120Hz(25°C) (%)	Leakage current (25°C, 5min) (μA)	Impedance (at 100kHz) (Ω)	Part No.
2.5	220	20	5.5	2.5	TCTAL0E227□
	330	30	16.5	2.5	TCTAL0E337□
4	100	20	4.0	3.0	TCTAL0G107□
	150	20	6.0	2.7	TCTAL0G157□
	220	20	20.0	2.5	TCTAL0G227□
6.3	68	20	4.3	4.0	TCTAL0J686□
	100	18	6.3	3.0	TCTAL0J107□
	150	30	94.5	2.7	TCTAL0J157□
10	33	15	3.3	4.0	TCTAL1A336□
	47	20	4.7	4.0	TCTAL1A476□
16	15	15	2.4	4.0	TCTAL1C156□
	22	20	3.6	4.0	TCTAL1C226□
20	10	15	2.0	8.0	TCTAL1D106□
25	4.7	15	1.2	8.0	TCTAL1E475□
	6.8	15	1.7	8.0	TCTAL1E685□
35	1.0	15	0.5	8.0	TCTAL1V105□
	1.5	15	0.5	8.0	TCTAL1V155□
	2.2	15	0.8	8.0	TCTAL1V225□
	3.3	15	1.2	8.0	TCTAL1V335□

□=Capacitance tolerance (M:±20%)

TCT series : CL case (6032-15[2412] Low profile size)

Rated voltage (V)	Capacitance (μF)	tan at 120Hz(25°C) (%)	Leakage current (25°C, 5min) (μA)	Impedance (at 100kHz) (Ω)	Part No.
2.5	470	18	11.8	0.5	TCTCL0E477□
4	330	16	13.2	0.7	TCTCL0G337□
6.3	220	14	13.9	0.8	TCTCL0J227□
10	150	12	15	1.3	TCTCL1A157□

□=Capacitance tolerance (M:±20%)

# Fail-safe open structure type

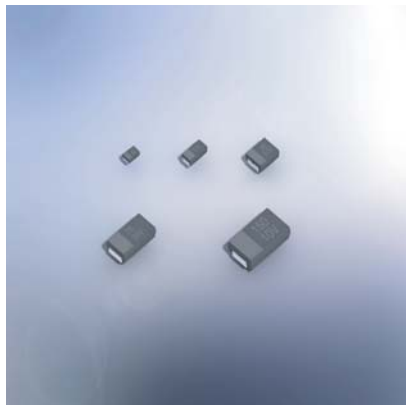

## TCFG Series

### Summary

High-reliability series with built-in (open) mechanism that shuts OFF the current during overheating.

### Features

- High reliability

### Applications

PC, PC peripherals, digital cameras, digital camcorders, automotive ITS-related devices, electronic office equipment, and more.

## Open mechanism built in for greater reliability

The open configuration stops current flow once the unit overheats, preventing damage to other parts of the circuit, contributing to worry-free design.

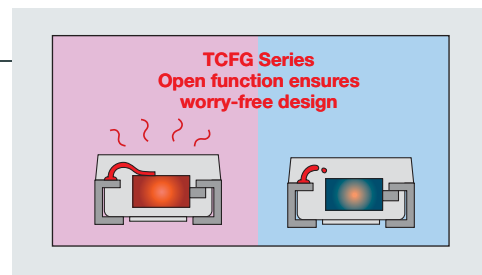

### Lineup

Available sizes ranging from the compact P case (2012-12[0805] size) to the oversized D case (7343-30[2917] size). The best selection in the industry allows for greater freedom of design.

RED : Under development

Capacitance code	Capacitance (μF)	Rated voltage (V, DC) / voltage code							
		2.5 e	4 g	6.3 j	10 A	16 C	20 D	25 E	
A	1.0 (105)				P	P A	P A	P A	
E	1.5 (155)			P	P A	P A	A	A	
J	2.2 (225)		P	P	P A	P A	A	A	
N	3.3 (335)		P	P A	P A	P A B	A B	A B	
S	4.7 (475)		P A	P A	P A B	A B	A B	A B	
W	6.8 (685)		P A	P A	P A B	A B	B		
a	10 (106)		P A	P A B	P A B	A B	B		
e	15 (156)		P A B	P A B	A B	B			
j	22 (226)		P A B	A B	A B	B			
n	33 (336)		A B	A B	B				
s	47 (476)		A B	A B	B	C		D	
w	68 (686)		A B	B	B C		D		
ā	100 (107)		B	B	B C	D			
ē	150 (157)		B	B C	B D				
j̄	220 (227)	B	B C	B D					
n̄	330 (337)	B	B D						

### Dimensions

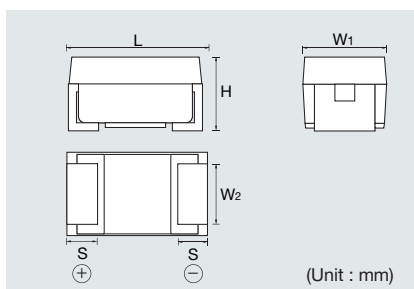

Case	L	W1	W2	H	S
P (2012-12[0805])	2.0±0.2	1.25±0.2	0.9±0.2	1.1±0.1	0.45±0.3
A (3216-18[1206])	3.2±0.2	1.6±0.2	1.2±0.2	1.6±0.2	0.8±0.3
B (3528-21[1411])	3.5±0.2	2.8±0.2	1.9±0.2	1.9±0.2	0.8±0.3
C (6032-27[2412])	6.0±0.2	3.2±0.2	2.2±0.1	2.5±0.2	1.3±0.2
D (7343-30[2917])	7.3±0.2	4.3±0.2	2.4±0.1	2.8±0.2	1.3±0.2

(Unit : mm)

Quick Reference

TCFG series : P case (2012-12[0805] size)

Rated voltage (V)	Capacitance (μF)	tan at 120Hz(25°C) (%)	Leakage current (25°C, 5min) (μA)	Impedance (at 100kHz) (Ω)	Part No.
4	2.2	10	0.5	17.5	TCFGP0G225□
	3.3	20	0.5	17.5	TCFGP0G335□
	4.7	20	0.5	14.4	TCFGP0G475□
	6.8	20	0.5	11.8	TCFGP0G685□
	10	20	0.5	9.3	TCFGP0G106□
	15	20	0.6	8.3	TCFGP0G156□
6.3	2.2	20	0.9	7.7	TCFGP0G226□
	1.5	10	0.5	17.5	TCFGP0J155□
	2.2	20	0.5	17.5	TCFGP0J225□
	3.3	20	0.5	14.4	TCFGP0J335□
	4.7	20	0.5	11.8	TCFGP0J475□
	6.8	20	0.5	9.3	TCFGP0J685□
10	10	20	0.6	8.3	TCFGP0J106□
	15	20	0.9	7.7	TCFGP0J156□
	1.0	10	0.5	17.5	TCFGP1A105□
	1.5	20	0.5	16.1	TCFGP1A155□
	2.2	20	0.5	14.4	TCFGP1A225□
	3.3	20	0.5	11.8	TCFGP1A335□
16	4.7	20	0.5	9.3	TCFGP1A475□
	6.8	20	0.7	8.3	TCFGP1A685□
	10	20	1.0	7.7	TCFGP1A106□
	1.0	10	0.5	16.1	TCFGP1C105□
	1.5	20	0.5	14.4	TCFGP1C155□
	2.2	20	0.5	11.8	TCFGP1C225□
20	3.3	20	0.6	9.3	TCFGP1C335□
	1.0	10	0.5	16.1	TCFGP1D105□
	25	1.0	10	0.5	16.1

□=Capacitance tolerance (M:±20%, K:±10%)

TCFG series : A case (3216-18[1206] size)

Rated voltage (V)	Capacitance (μF)	tan at 120Hz(25°C) (%)	Leakage current (25°C, 5min) (μA)	Impedance (at 100kHz) (Ω)	Part No.	
4	4.7	6	0.5	5.6	TCFGA0G475□	
	6.8	8	0.5	4.9	TCFGA0G685□	
	10	8	0.5	4.2	TCFGA0G106□	
	15	8	0.6	4.0	TCFGA0G156□	
	22	8	0.9	3.0	TCFGA0G226□	
	33	10	1.3	3.5	TCFGA0G336□	
	47	12	1.9	3.2	TCFGA0G476□	
	68	16	3.0	3.0	TCFGA0G686□	
	6.3	3.3	6	0.5	5.6	TCFGA0J335□
		4.7	8	0.5	4.9	TCFGA0J475□
6.8		8	0.5	4.2	TCFGA0J685□	
10		8	0.6	4.0	TCFGA0J106□	
15		8	0.9	3.0	TCFGA0J156□	
22		10	1.4	3.5	TCFGA0J226□	
33		12	2.1	3.2	TCFGA0J336□	
47		18	3.0	3.2	TCFGA0J476□	
10		1.5	6	0.5	8.8	TCFGA1A155□
		2.2	6	0.5	5.6	TCFGA1A225□
	3.3	8	0.5	4.9	TCFGA1A335□	
	4.7	8	0.5	4.2	TCFGA1A475□	
	6.8	8	0.7	4.0	TCFGA1A685□	
	10	8	1.0	3.0	TCFGA1A106□	
	15	10	1.5	3.5	TCFGA1A156□	
	22	12	2.2	3.2	TCFGA1A226□	
	16	1.0	6	0.5	7.0	TCFGA1C105□
		1.5	6	0.5	5.6	TCFGA1C155□
2.2		6	0.5	4.9	TCFGA1C225□	
3.3		6	0.5	4.8	TCFGA1C335□	
4.7		6	0.8	3.9	TCFGA1C475□	
6.8		6	1.1	3.8	TCFGA1C685□	
10		8	1.6	3.5	TCFGA1C106□	
20		1.0	6	0.5	7.0	TCFGA1D105□
		1.5	6	0.5	6.0	TCFGA1D155□
		2.2	6	0.5	5.2	TCFGA1D225□
	3.3	6	0.7	4.8	TCFGA1D335□	
	4.7	6	0.9	3.9	TCFGA1D475□	
25	1.0	6	0.5	7.0	TCFGA1E105□	
	1.5	6	0.5	6.0	TCFGA1E155□	
	2.2	6	0.6	5.2	TCFGA1E225□	
	3.3	6	0.8	4.8	TCFGA1E335□	
	4.7	8	1.2	3.4	TCFGA1E475□	

□=Capacitance tolerance (M:±20%, K:±10%)

TCFG series : B case (3528-21[1411] size)

Rated voltage (V)	Capacitance (μF)	tan at 120Hz(25°C) (%)	Leakage current (25°C, 5min) (μA)	Impedance (at 100kHz) (Ω)	Part No.	
2.5	220	18	5.5	1.5	TCFGB0E227□	
4	15	8	0.6	3.0	TCFGB0G156□	
	22	8	0.9	3.0	TCFGB0G226□	
	33	8	1.3	2.5	TCFGB0G336□	
	47	10	1.9	2.0	TCFGB0G476□	
	68	10	2.7	1.9	TCFGB0G686□	
	100	12	4.0	1.6	TCFGB0G107□	
	150	18	6.3	1.3	TCFGB0G157□	
	220	20	8.8	1.3	TCFGB0G227□	
6.3	10	8	0.6	3.0	TCFGB0J106□	
	15	8	0.9	3.0	TCFGB0J156□	
	22	8	1.4	2.5	TCFGB0J226□	
	33	8	2.1	2.0	TCFGB0J336□	
	47	10	3.0	1.9	TCFGB0J476□	
	68	12	4.3	1.6	TCFGB0J686□	
	100	12	6.3	1.6	TCFGB0J107□	
	150	18	9.5	1.5	TCFGB0J157□	
	220	30	70	1.3	TCFGB0J227□	
	10	4.7	6	0.5	3.0	TCFGB1A475□
6.8		8	0.7	3.0	TCFGB1A685□	
10		8	1.0	3.0	TCFGB1A106□	
15		8	1.5	2.5	TCFGB1A156□	
22		8	2.2	2.0	TCFGB1A226□	
33		10	3.3	1.9	TCFGB1A336□	
47		10	4.7	1.6	TCFGB1A476□	
16		3.3	6	0.5	4.2	TCFGB1C335□
		4.7	6	0.8	3.0	TCFGB1C475□
		6.8	6	1.1	3.0	TCFGB1C685□
	10	6	1.6	2.5	TCFGB1C106□	
	15	6	2.4	2.0	TCFGB1C156□	
	22	6	3.5	1.9	TCFGB1C226□	
	20	3.3	6	0.66	4.2	TCFGB1D335□
	25	3.3	6	0.83	4.2	TCFGB1E335□
		4.7	6	1.2	3.0	TCFGB1E475□

□=Capacitance tolerance (M:±20%, K:±10%)

TCFG series : C case (6032-27[2412] size)

Rated voltage (V)	Capacitance (μF)	tan at 120Hz(25°C) (%)	Leakage current (25°C, 5min) (μA)	Impedance (at 100kHz) (Ω)	Part No.
6.3	150	12	9.5	1.3	TCFGC0J157□
10	100	10	10.0	1.3	TCFGC1A107□
16	47	8	7.5	1.6	TCFGC1C476□

□=Capacitance tolerance (M:±20%)

TCFG series : D case (7343-30[2917] size)

Rated voltage (V)	Capacitance (μF)	tan at 120Hz(25°C) (%)	Leakage current (25°C, 5min) (μA)	Impedance (at 100kHz) (Ω)	Part No.
6.3	220	12	13.8	0.7	TCFGD0J227□
10	150	10	15.0	0.7	TCFGD1A157□
16	100	10	16.0	0.7	TCFGD1C107□
25	47	10	11.8	0.7	TCFGD1E476□

□=Capacitance tolerance (M:±20%)

# Standard Type

## TC Series



### Summary

Advanced semiconductor manufacturing technology developed for transistors and diodes are utilized for stable quality control and superior productivity.

Available in two package types, P Case [2012-12 (0805) size] and A Case [3216-18 (1206) size], this lineup is designed for large capacitance in a compact form factor.

### Features

- Compact

### Applications

PCs, PC peripherals, mobile phones, digital cameras, digital camcorders, and more.

### Lineup

Capacitance code	Capacitance (μF)	Rated voltage (V, DC) / voltage code														
		4 g	6.3 j	10 A	16 C	20 D	25 E	RED : Under development								
A	1.0 (105)			P	P	A	P	A	P	A	P	A				
E	1.5 (155)		P	P	A	P	A	P	A	P	A	P	A			
J	2.2 (225)	P	P	P	A	P	A	P	A	P	A	P	A			
N	3.3 (335)	P	P	P	A	P	A	P	A	P	A	P	A			
S	4.7 (475)	P	A	P	A	P	A	P	A	P	A	P	A			
W	6.8 (685)	P	A	P	A	P	A	P	A	P	A	P	A			
a	10 (106)	P	A	P	A	P	A	P	A	P	A	P	A			
e	15 (156)	P	A	P	A	P	A	P	A	P	A	P	A			
j	22 (226)	P	A	P	A	P	A	P	A	P	A	P	A			
n	33 (336)	P	A	P	A	P	A	P	A	P	A	P	A			
s	47 (476)	P	A	P	A	P	A	P	A	P	A	P	A			
w	68 (686)	P	A	P	A	P	A	P	A	P	A	P	A			
ā	100 (107)	P	A	P	A	P	A	P	A	P	A	P	A			

### Dimensions

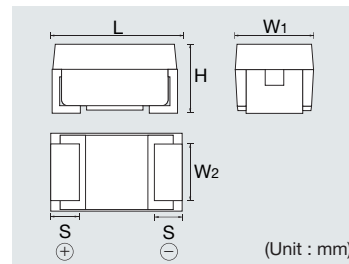

(Unit : mm)

Case	L	W1	W2	H	S
P (2012-12[0805])	2.0±0.2	1.25±0.2	0.9±0.2	1.1±0.1	0.45±0.3
A (3216-18[1206])	3.2±0.2	1.6±0.2	1.2±0.2	1.6±0.2	0.8±0.3

### Quick Reference

TC series : P case (2012-12[0805] size)

Rated voltage (V)	Capacitance (μF)	tan at 120Hz(25°C) (%)	Leakage current (25°C, 5min) (μA)	Impedance (at 100kHz) (Ω)	Part No.
4	2.2	10	0.5	17.5	TCP0G225
	3.3	20	0.5	17.5	TCP0G335
	4.7	20	0.5	14.4	TCP0G475
	6.8	20	0.5	11.8	TCP0G685
	10	20	0.5	9.3	TCP0G106
	15	20	0.6	8.3	TCP0G156
	22	20	0.9	7.7	TCP0G226
	6.3	1.5	10	0.5	17.5
2.2		20	0.5	17.5	TCP0J225
3.3		20	0.5	14.4	TCP0J335
4.7		20	0.5	11.8	TCP0J475
6.8		20	0.5	9.3	TCP0J685
10		20	0.6	8.3	TCP0J106
15		20	0.9	7.7	TCP0J156
22		25	1.4	5.0	TCP0J226
10	1.0	10	0.5	17.5	TCP1A105
	1.5	20	0.5	16.1	TCP1A155
	2.2	20	0.5	14.4	TCP1A225
	3.3	20	0.5	11.8	TCP1A335
	4.7	20	0.5	9.3	TCP1A475
	6.8	20	0.7	8.3	TCP1A685
	10	20	1.0	7.7	TCP1A106
	16	1.0	10	0.5	16.1
20		10	0.5	16.1	TCP1D105
25	1.0	20	0.6	9.3	TCP1E105

□=Capacitance tolerance (M:±20%, K:±10%)

TC series : A case (3216-18[1206] size)

Rated voltage (V)	Capacitance (μF)	tan at 120Hz(25°C) (%)	Leakage current (25°C, 5min) (μA)	Impedance (at 100kHz) (Ω)	Part No.	
4	4.7	6	0.5	5.6	TCA0G475	
	6.8	8	0.5	4.9	TCA0G685	
	10	8	0.5	4.2	TCA0G106	
	15	8	0.6	4.0	TCA0G156	
	22	8	0.9	3.0	TCA0G226	
	33	10	1.3	3.5	TCA0G336	
	47	12	1.9	3.2	TCA0G476	
	68	18	2.7	3.0	TCA0G686	
	100	30	4.0	3.0	TCA0G107	
	6.3	3.3	6	0.5	5.6	TCA0J335
4.7		8	0.5	4.9	TCA0J475	
6.8		8	0.5	4.2	TCA0J685	
10		8	0.6	4.0	TCA0J106	
15		8	0.9	3.0	TCA0J156	
22		10	1.4	3.5	TCA0J226	
33		12	2.1	3.2	TCA0J336	
47		18	3.0	3.2	TCA0J476	
10	1.5	6	0.5	8.8	TCA1A155	
	2.2	6	0.5	5.6	TCA1A225	
	3.3	8	0.5	4.9	TCA1A335	
	4.7	8	0.5	4.2	TCA1A475	
	6.8	8	0.7	4.0	TCA1A685	
	10	8	1.0	3.0	TCA1A106	
	15	10	1.5	3.5	TCA1A156	
	22	12	2.2	3.2	TCA1A226	
16	1.0	6	0.5	7.0	TCA1C105	
	1.5	6	0.5	5.6	TCA1C155	
	2.2	6	0.5	4.9	TCA1C225	
	3.3	6	0.5	4.8	TCA1C335	
	4.7	6	0.8	3.9	TCA1C475	
	6.8	6	1.1	3.8	TCA1C685	
	10	8	1.6	3.5	TCA1C106	
	20	1.0	6	0.5	7.0	TCA1D105
1.5		6	0.5	6.0	TCA1D155	
2.2		6	0.5	5.2	TCA1D225	
3.3		6	0.7	4.8	TCA1D335	
4.7		6	0.9	3.9	TCA1D475	
25		1.0	6	0.5	7.0	TCA1E105
		1.5	6	0.5	6.0	TCA1E155
		2.2	6	0.6	5.2	TCA1E225
	3.3	6	0.8	4.8	TCA1E335	
	4.7	8	1.2	3.4	TCA1E475	

□=Capacitance tolerance (M:±20%, K:±10%)

# Conductive polymer bottom surface electrode type



## TCTO Series

### Summary

This high performance series puts an ultra-low ESR conductive polymer into a bottom electrode package, resulting in large capacitance in a compact, low-profile form factor.

### Features

- Ultra-low ESR
- Non-combustible
- Thin
- Compact
- High capacitance

### Applications

PCs, PC peripherals, digital cameras, digital camcorders, car audio, LCD TVs, and more.

## Ultra-low ESR / Low Profile / Large Capacitance

ROHM now offers conductive polymer tantalum capacitors in a bottom electrode package configuration for ultra-low ESR with high resistance to combustion. The TCTO series offers these qualities along with large capacitance (100uF max.) in a compact, low-profile form factor (3.2x1.6mm, t=1.1mm).

M and P Case products are currently under development for compact applications.

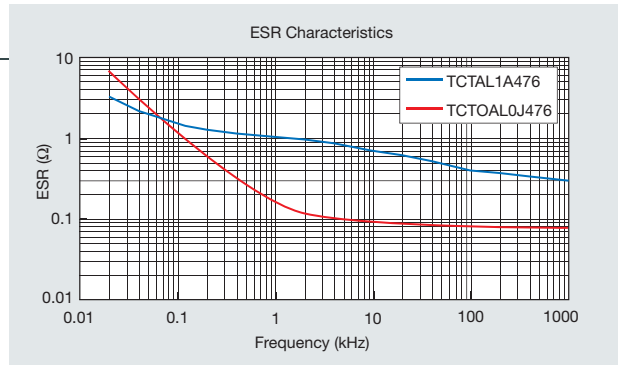

### Lineup

RED : Under development

Capacitance code	Capacitance (μF)	Rated voltage (V, DC) / voltage code			
		2.5 e	4 g	6.3 j	10 A
A	1.0 (105)				
J	2.2 (225)				M
N	3.3 (335)				P M AL
S	4.7 (475)				P M AL
W	6.8 (685)			M	P M AL
a	10 (106)		M	M	P AL
e	15 (156)	M	M		P AL
j	22 (226)	M		P	P AL
n	33 (336)		P	P	AL
s	47 (476)	P	P		AL
w	68 (686)	P		AL	AL
ā	100 (107)		AL	AL	
ē	150 (157)		AL		

### Dimensions

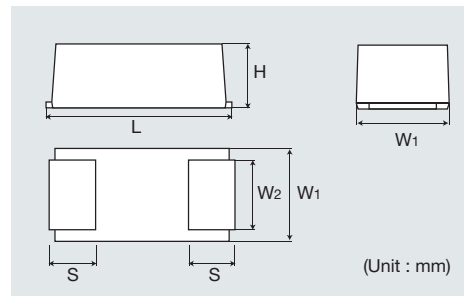

(Unit : mm)

Case	L	W1	W2	H	S
M (1608-09[0603])	1.6±0.1	0.85±0.1	0.55±0.1	0.8±0.1	0.5±0.1
P (2012-12[0805])	2.0±0.2	1.25±0.2	0.85±0.2	1.1±0.1	0.5±0.1
AL (3216-12[1206] Low profile)	3.2±0.2	1.6±0.2	1.2±0.2	1.1±0.1	0.8±0.2

### Quick Reference

TCTO series : AL case (3216-12[1206] Low profile size)

Rated voltage (V)	Capacitance (μF)	tan at 120Hz(25°C) (%)	Leakage current (25°C, 5min) (μA)	Impedance (at 100kHz) (Ω)	Part No.
2.5	100	10	25.0	200	TCTOAL0E107□
4	68	10	27.2	200	TCTOAL0G686□
6.3	47	10	29.6	200	TCTOAL0J476□
10	22	6	22.0	200	TCTOAL1A226□
	33	10	33.0	200	TCTOAL1A336□

□=Capacitance tolerance (M:±20%)

# Conductive polymer type

## TCO Series



### Summary

This series utilizes conductive polymers in the cathode for significantly reduced ESR characteristics.

### Features

- Ultra-low ESR
- Non-combustible

### Applications

PCs, PC peripherals, digital cameras/camcorders, portable audio players, automotive ITS-related devices, and more.

## Ultra-low ESR • Non-combustible

ESR has been significantly reduced due to utilization of a conductive polymer instead of conventional manganese dioxide. In addition the conductive polymer type reduces the risk of smoke or fire compared with conventional products.

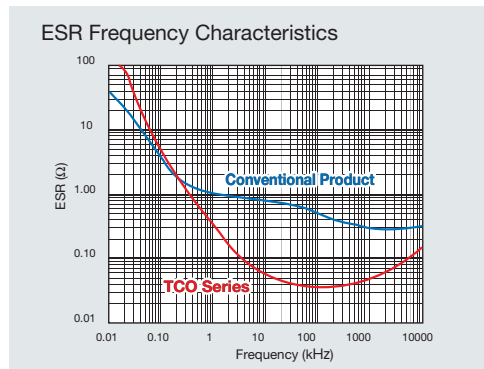
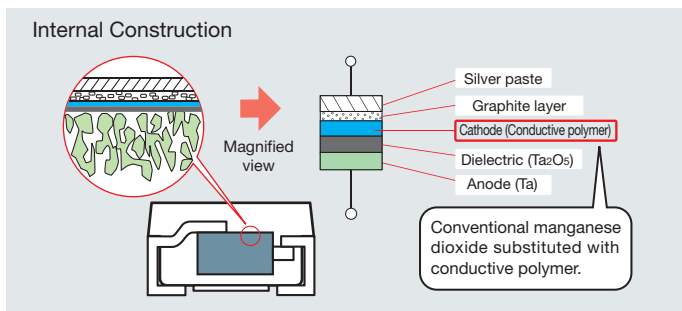

### Lineup

In addition to its compact size and large capacitance, the TCO series features low ESR characteristics over a broad frequency band, making it perfect for noise absorption in high-frequency circuits.

A broad lineup is offered, ensuring compatibility with a wide variety of applications, including mobile phones, notebook PCs, and other data communications devices.

RED : Under development

Capacitance code	Capacitance (μF)	Rated voltage (V, DC) / voltage code			
		2.5 e	4 g	6.3 j	10 A
n	33 (336)			B	B
s	47 (476)			B	B
w	68 (686)			B	
ā	100 (107)			B	
ē	150 (157)		B	B	
j	220 (227)	B	B		
ñ	330 (337)	B			

### Dimensions

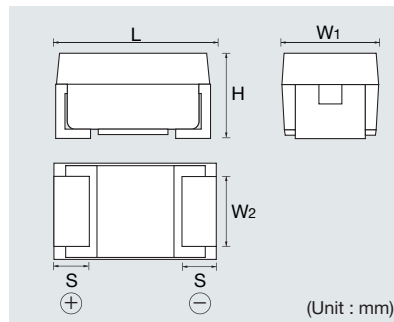

Case	L	W <sub>1</sub>	W <sub>2</sub>	H	S
B (3528-21[1411])	3.5±0.2	2.8±0.2	1.9±0.2	1.9±0.2	0.8±0.3

### Quick Reference

TCO series : B case (3528-21[1411] size)

Rated voltage (V)	Capacitance (μF)	tan at 120Hz(25°C) (%)	Leakage current (25°C, 5min) (μA)	Impedance (at 100kHz) (Ω)	Part No.	
4	150	8	60	150	TCOB0G157□	
	6.3	33	8	21	150	TCOB0J336□
		47	8	30	150	TCOB0J476□
10	100	8	63	150	TCOB0J107□	
	33	8	33	150	TCOB1A336□	
	47	8	47	150	TCOB1A476□	

□=Capacitance tolerance (M:±20%)

# Recommended soldering conditions

## TCT/TCFG/TC Series

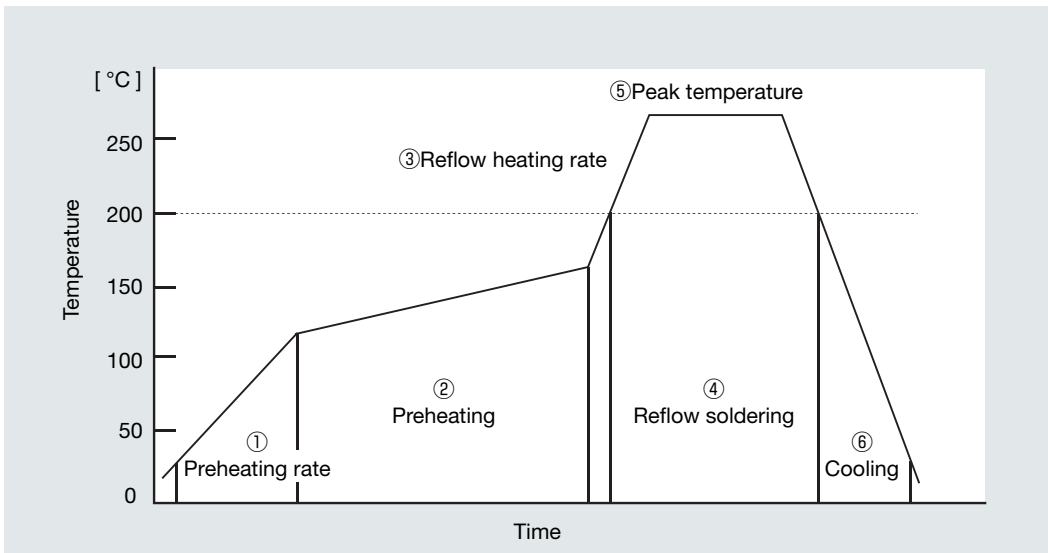

[ Recommended reflow soldering conditions ]

- ① Preheating rate : 1 to 5°C/s
- ② Preheating : 120 to 160°C , 50 to 120s
- ③ Reflow heating rate : 1 to 5°C/s
- ④ Soldering (high temperature period) : 200°C , 30 to 60s
- ⑤ Peak temperature : 230 to 260°C , 10s Max.
- ⑥ Cooling : 60s Min.
- ⑦ Reflow count : 2 times Max.

[ Recommended hand soldering conditions ]

- ① Solder tip temperature : 350°C Max. (TCFG series 300°C Max.)
- ② Time : 5s Max.

\* TCT series is not suitable for flow soldering.

## Recommended land pattern dimensions

(Unit : mm)

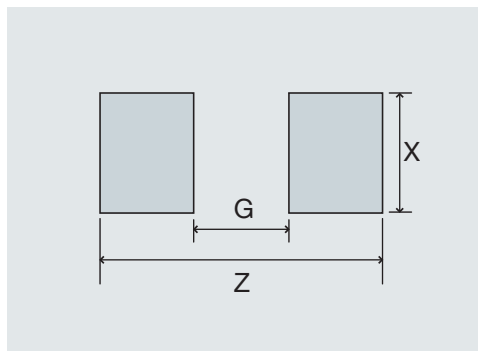

Series	Case size	X	G	Z
TCT	U (1005-06[0402])	0.5	0.4	1.5
	PL (2012-10[0805] Low profile)	0.95	1.1	2.9
	P (2012-12[0805])	0.95	1.1	2.9
	AS (3216-10[1206] Ultra Low Profile)	1.25	1.7	4.1
	AL (3216-12[1206] Low profile)	1.25	1.7	4.1
	CL (6032-15[2412] Low profile)	2.3	3.45	8.05
TCFG	P (2012-12[0805])	1.1	0.8	3.4
	A (3216-18[1206])	1.4	1.2	5.2
	B (3528-21[1411])	2.7	1.4	5.6
	C (6032-27[2412])	2.7	2.9	6.9
	D (7343-30[2917])	2.9	4.1	8.2
TC	M (1608-09[0603])	0.65	0.65	2.2
	P (2012-12[0805])	1.1	0.8	3.4
	A (3216-18[1206])	1.4	1.2	5.2

TCO/TCTO Series

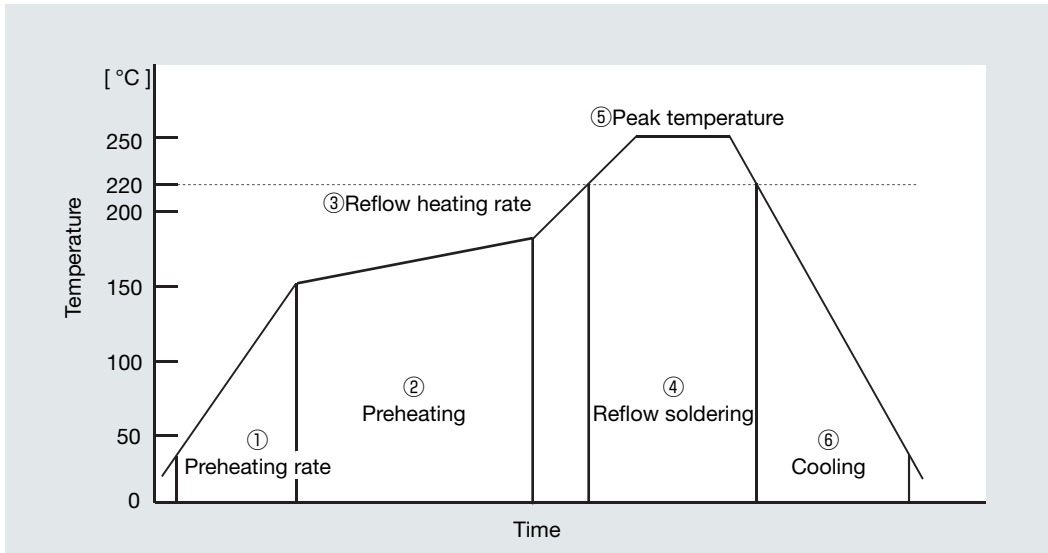

[ Recommended reflow soldering conditions ]

[ Recommended hand soldering conditions ]

- ① Preheating rate : 2°C/s
- ② Preheating : 150 to 180°C , 120s Max.
- ③ Reflow heating rate : 1.5°C/s
- ④ Soldering (high temperature period) : 220°C , 40s
- ⑤ Peak temperature : 250°C , 5s Max.
- ⑥ Cooling : 60s Min.
- ⑦ Reflow count : 2 times Max.

- ① Solder tip temperature : 350°C Max.
  - ② Time : 3s Max.
- \* Not suitable for flow soldering

Recommended land pattern dimensions

(Unit : mm)

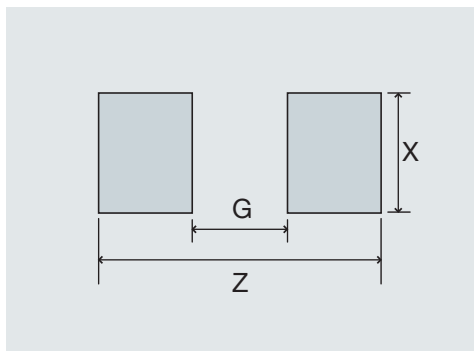

Series	Case size	X	G	Z
TCO	B (3528-21[1411])	2.7	1.4	5.6
TCTO	M (1608-09[0603])	0.65	0.65	2.2
	P (2012-12[0805])	0.95	1.1	2.9
	AL (3216-12[1206] Low profile)	1.25	1.7	4.1

# Part Number Explanation

**T C A 0 J 1 0 6 M 8 R**

Series name	Case style	Rated voltage	Capacitance tolerance	Code	Capacitance tolerance	Code	Tape width	Parts orientation
<b>TCT</b>	<b>U</b> 1005-06(0402)	<b>0E</b> 2.5	Nominal capacitance in pF in 3 digits : 2 significant figures followed by the figure representing the number of 0's.	<b>K</b>	±10%	<b>8</b>	8mm	R : Positive electrode on the side opposite to sprocket hole
<b>TCFG</b>	<b>M</b> 1608-09(0603)	<b>0G</b> 4		<b>M</b>	±20%	<b>C</b>	12mm	
<b>TC</b>	<b>PL</b> 2012-10(0805) Low profile	<b>0J</b> 6.3						
<b>TCO</b>	<b>P</b> 2012-12(0805)	<b>1A</b> 10						
<b>TCTO</b>	<b>AS</b> 3216-10(1206) Ultra low profile	<b>1C</b> 16						
	<b>AL</b> 3216-12(1206) Low profile	<b>1D</b> 20						
	<b>A</b> 3216-18(1206)	<b>1E</b> 25						
	<b>B</b> 3528-21(1411)	<b>1V</b> 35						
	<b>CL</b> 6032-12(2142) Low profile							
	<b>C</b> 6032-27(2412)							
	<b>D</b> 7343-30(2917)							

# Taping Specifications

## Reel Dimensions and Quantity

Case code	Packing amount (pcs)	Tape width ±0.3(mm)	Reel diameter 0 (mm)	W1 +1.0 0 (mm)	W2 ±0.1 (mm)
U (1005-06[0402])	10000	8.0	φ180	9.0	11.4
M (1608-09[0603])	4000				
PL (2012-10[0805] Low profile)	3000				
P (2012-12[0805])					
AS (3216-10[1206] Ultra low profile)					
AL (3216-12[1206] Low profile)	2000				
A (3216-18[1206])					
B (3528-21[1411])	1000	12.0		13.0	15.4
CL (6032-12[2142] Low profile)					
C (6032-27[2412])					
D (7343-30[2917])	500				

(Unit : mm)  
EIAJ ET-7200B compatible

## Embossed Carrier Tape Specifications

(Unit : mm)

Case name	A±0.1	B±0.1	W±0.2	E±0.1	F±0.05	P1±0.1	P2±0.05	P0±0.1	D0±0.1	t1±0.05	t2±0.1
U (1005-06[0402])	0.75	1.25	8.0	1.75	3.5	2.0	2.0	4.0	φ1.5	0.2	0.6
M (1608-09[0603])	1.0	1.85				0.2				1.0	
PL (2012-10[0805] Low profile)	1.6	2.4				0.25				1.05	
P (2012-12[0805])	1.55	2.3								1.5	
AS (3216-10[1206] Ultra low profile)	1.9	3.5								1.1	
AL (3216-12[1206] Low profile)	1.9	3.5								1.3	
A (3216-18[1206])	1.9	3.5	12.0		5.5	8.0			0.25	1.9	
B (3528-21[1411])	3.3	3.8							2.2		
CL (6032-12[2142] Low profile)	3.5	6.6							1.7		
C (6032-27[2412])	3.7	6.4							3.0		
D (7343-30[2917])	4.8	7.7							0.3	3.0	
											3.0

## Usage Precautions

- 1 Verification and confirmation of performance characteristics of products, after mounting on board, is strongly advised.
- 2 In particular, if a transient load (a large load applied in a short period of time, such as pulse) is applied, confirmation of performance characteristics after mounting on board is strongly recommended. Avoid applying power exceeding the normal rated power, since exceeding the power rating under steady state load conditions may negatively affect product performance and reliability.
- 3 Allowable ripple voltage  
The sum of the peak values of DC and AC voltage should not exceed the rated voltage. The ripple voltage, if applied, should not exceed the maximum allowable value. The allowable ripple voltage at different temperatures is calculated using the formulas below.
 

$$E = \text{Allowable ripple voltage}$$

$$E \text{ Max. (at } 50^{\circ}\text{C)} = 0.7 \times E \text{ Max. (at } 25^{\circ}\text{C)}$$

$$E \text{ Max. (at } 85^{\circ}\text{C)} = 0.5 \times E \text{ Max. (at } 25^{\circ}\text{C)}$$

$$E \text{ Max. (at } 125^{\circ}\text{C)} = 0.3 \times E \text{ Max. (at } 25^{\circ}\text{C)}$$
- 4 The voltage should be reduced as much as possible.  
In particular, a voltage lower than 1/3 of the rated voltage is recommended when used in a low impedance circuit.
- 5 The tester must not be in contact with a capacitor. If this occurs, an excessive or reverse voltage may be applied to the capacitor.
- 6 Please refer to the derating curve during operation from 85°C to 125°C.
- 7 Apply a series-resistor rated at 3W per 1V.
- 8 When a highly active halogenous (i.e. chlorine, bromine) flux is used, the remainder of flux may negatively affect product performance and reliability. Therefore, a halogen-free flux should be used.
- 9 Reflow soldering is recommended. However, if flow soldering will be performed please consult with ROHM in advance.

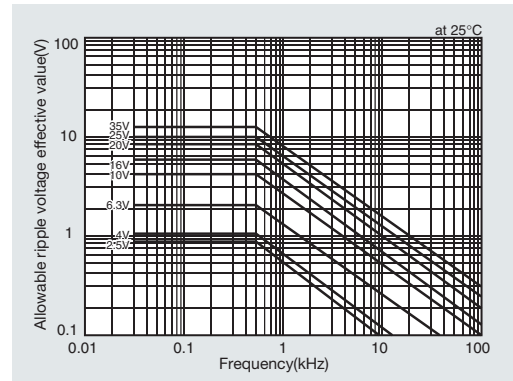

For basic guidelines on using chip tantalum capacitors, please refer to the technical reports issued by Japan Electronic and Information Technology Industries Association.

[ JEITA RCR-2368B: Guidelines for notes on fixed tantalum electrolytic capacitors for electronic equipment.  
(Application Safety Guide for fixed electrolytic tantalum capacitors) ]

The content specified in this document is correct as of 1st June, 2009.

No copying or reproduction of this document, in part or in whole, is permitted without the consent of ROHM Co.,Ltd.

The content specified herein is subject to change for improvement without notice.

The content specified herein is for the purpose of introducing ROHM's products (hereinafter "Products"). If you wish to use any such Product, please be sure to refer to the specifications, which can be obtained from ROHM upon request. Examples of application circuits, circuit constants and any other information contained herein illustrate the standard usage and operations of the Products. The peripheral conditions must be taken into account when designing circuits for mass production.

Great care was taken in ensuring the accuracy of the information specified in this document. However, should you incur any damage arising from any inaccuracy or misprint of such information, ROHM shall bear no responsibility for such damage.

The technical information specified herein is intended only to show the typical functions of and examples of application circuits for the Products. ROHM does not grant you, explicitly or implicitly, any license to use or exercise intellectual property or other rights held by ROHM and other parties. ROHM shall bear no responsibility whatsoever for your use of any Product outside of the prescribed scope or not in accordance with the instruction manual.

The Products specified in this document are intended to be used with general-use electronic equipment or devices (such as audio visual equipment, office-automation equipment, communication devices, electronic appliances and amusement devices).

The Products specified in this document are not designed to be radiation tolerant.

While ROHM always makes efforts to enhance the quality and reliability of its Products, a Product may fail or malfunction for a variety of reasons.

Please be sure to implement in your equipment using the Products safety measures to guard against the possibility of physical injury, fire or any other damage caused in the event of the failure of any Product, such as derating, redundancy, fire control and fail-safe designs. ROHM shall bear no responsibility whatsoever for your use of any Product outside of the prescribed scope or not in accordance with the instruction manual.

The Products are not designed or manufactured to be used with any equipment, device or system which requires an extremely high level of reliability the failure or malfunction of which may result in a direct threat to human life or create a risk of human injury (such as a medical instrument, transportation equipment, aerospace machinery, nuclear-reactor controller, fuel-controller or other safety device). ROHM shall bear no responsibility in any way for use of any of the Products for the above special purposes. If a Product is intended to be used for any such special purpose, please contact a ROHM sales representative before purchasing.

If you intend to export or ship overseas any Product or technology specified herein that may be controlled under the Foreign Exchange and the Foreign Trade Law, you will be required to obtain a license or permit under the Law.

## ROHM Sales Offices

Contact us for further information about the products.

R0039A

<b>San Diego</b> +1-858-625-3630	<b>United Kingdom</b> +44-1-908-272400	<b>Tianjin</b> +86-22-23029181	<b>Xiamen</b> +86-592-238-5705
<b>Atlanta</b> +1-770-754-5972	<b>Denmark</b> +45-3694-4739	<b>Shanghai</b> +86-21-6279-2727	<b>Zhuhai</b> +86-756-3232-480
<b>Boston</b> +1-978-371-0382	<b>Espoo</b> +358-9725-54491	<b>Hangzhou</b> +86-571-87658072	<b>Hong Kong</b> +852-2-740-6262
<b>Chicago</b> +1-847-368-1006	<b>Salo</b> +358-2-7332234	<b>Nanjing</b> +86-25-8689-0015	<b>Taipei</b> +886-2-2500-6956
<b>Dallas</b> +1-972-473-3748	<b>Oulu</b> +358-8-5372930	<b>Ningbo</b> +86-574-87654201	<b>Kaohsiung</b> +886-7-237-0881
<b>Denver</b> +1-303-708-0908	<b>Barcelona</b> +34-9375-24320	<b>Qingdao</b> +86-532-8577-9312	<b>Singapore</b> +65-6332-2322
<b>Detroit</b> +1-248-348-9920	<b>Hungary</b> +36-1-4719338	<b>Suzhou</b> +86-512-6807-1300	<b>Philippines</b> +63-2-807-6872
<b>Nashville</b> +1-615-620-6700	<b>Poland</b> +48-22-5757213	<b>Wuxi</b> +86-510-82702693	<b>Thailand</b> +66-2-254-4890
<b>Mexico</b> +52-33-3123-2001	<b>Russia</b> +7-495-739-41-74	<b>Guangzhou</b> +86-20-3878-8100	<b>Kuala Lumpur</b> +60-3-7958-8355
<b>Düsseldorf</b> +49-2154-9210	<b>Seoul</b> +82-2-8182-700	<b>Huizhou</b> +86-752-205-1054	<b>Penang</b> +60-4-2286453
<b>Munich</b> +49-8999-216168	<b>Masan</b> +82-55-240-6234	<b>Fuzhou</b> +86-591-8801-8698	<b>Kyoto</b> +81-75-365-1218
<b>Stuttgart</b> +49-711-7272-370	<b>Dalian</b> +86-411-8230-8549	<b>Dongguan</b> +86-769-8393-3320	<b>Yokohama</b> +81-45-476-2290
<b>France</b> +33-1-5697-3060	<b>Beijing</b> +86-10-8525-2483	<b>Shenzhen</b> +86-755-8307-3008	

## ROHM Co.,Ltd.

21 Sain Mizosaki-cho, Ukyo-ku,  
Kyoto 615-8585 Japan  
TEL : +81-75-311-2121 FAX : +81-75-315-0172

[www.rohm.com](http://www.rohm.com)

