

2009

Product Catalog

ROHM
SEMICONDUCTOR

Passive Components

Resistors / EMI Filters



Resistors

ROHM, the pioneer in chip resistors, offers a broad lineup, ranging from the ultra-compact MCR004 series units and the high reliability surge-resistant ESR series to high voltage resistance models (KTR series) and products optimized for current detection (PMR series). Select the ideal solution to fit set requirements.

EMI Filters



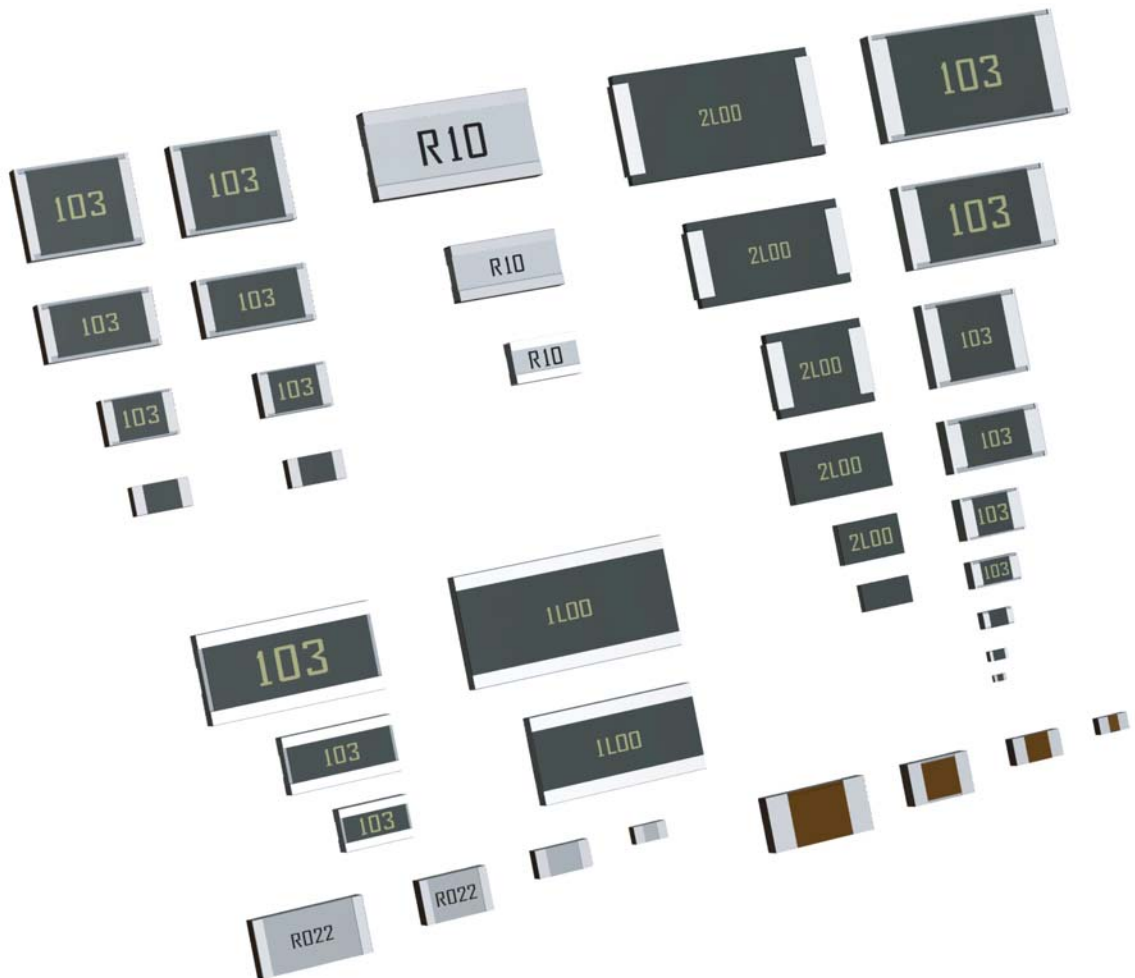

ROHM 1608-sized 3-terminal EMI filters are available in a number of capacitances and are specifically designed for removal of onboard differential mode noise over a wide range of frequencies.



Contents

Resistor Lineup	3~5
Low Ohmic Lineup Distribution Chart	4
Thick Film Low Ohmic Chip Resistors	6
UCR Series	
Ultra-low Ohmic Chip Resistors for Current Detection	7
PMR Series	
Ultra-low Ohmic Wide Terminal Chip Resistors	8
for Current Detection	
PML Series	
High Power Wide Terminal Chip Resistors	9
(Low Ohmic Type)	
LTR Series	
High Power Wide Terminal Chip Resistors	10
LTR Series	
Anti-surge Chip Resistors	11
ESR Series	
High Voltage Resistance Chip Resistors	12
KTR Series	
Sulfur-resistant Chip Resistors	13
TRR Series	
0402 Size Ultra-compact Chip Resistors	14
MCR004 Series	
Narrow Pitch Paper Tape Chip Resistors	15
MCR03 Series	
3-Terminal EMI Filters	16
MCF18 Series	
Dimensions	17,18

Resistor Lineup

Part No.	Size (inch)	Circuit	Rated power (W)	Tolerance	Temperature coefficient (ppm/°C)	Resistance range (Ω)	Operating temperature range (°C)	
Compact Thick Film Chip Resistors <MCR Series>								
New MCR004	0402 (01005)		0.031	J (±5%)	±250	10 to 3M	-55 to +125	
				F (±1%)	±250	10 to 3M		
MCR006	0603 (0201)		0.05	J (±5%)	+600/-200/±250 *	1 to 10M		
				F (±1%)	±250	10 to 10M		
				D (±0.5%)	±200/±100 *	10 to 1M		
MCR01	1005 (0402)		0.063	J (±5%)	+500/-250/±200 *	1 to 10M		
				F (±1%)	±100	10 to 2.2M		
				D (±0.5%)	±100/±50 *	10 to 1M		
MCR03	1608 (0603)		0.1	J (±5%)	±400/±200 *	1 to 10M	-55 to +155	
				FX (±1%)	±100	10 to 10M		
				D (±0.5%)	±100/±50 *	10 to 1M		
MCR10	2012 (0805)		0.125	J (±5%)	±400/±200 *	1 to 10M		
		F (±1%)		±100	10 to 2.2M			
			D (±0.5%)	±100/±50 *	10 to 1M			
Thick Film Chip Resistors <MCR Series>								
MCR18	3216 (1206)		0.25	J (±5%)	±400/±200	1 to 10M	-55 to +155	
				F (±1%)	±100	10 to 2.2M		
				D (±0.5%)	±100/±50	10 to 1M		
MCR25	3225 (1210)		0.25	J (±5%)	500±350/±500/±200	1 to 3.3M		
				F (±1%)	±100	10 to 1M		
MCR50	5025 (2010)		0.5	J (±5%)	500±350/±500/±200/±350	1 to 560k	-55 to +125	
		F (±1%)		±100	10 to 180k			
MCR100	6432 (2512)		1	J (±5%)	500±350/±500/±350/±200	1 to 100k		
				F (±1%)	±100	10 to 82k		
Low Ohmic Thick Film Chip Resistors <MCR Series>								
MCR01	1005 (0402)		1/16(0.063)	F (±1%)	±400	1.0 to 9.1	-55 to +155	
MCR03	1608 (0603)			F (±1%)	±400	1.0 to 9.1		
			1/4(0.25)	J (±5%)	500±300	0.047 to 0.091		
					400±200	0.1 to 0.13		
				F (±1%)	±250	0.15 to 0.91		
					500±300	0.047 to 0.091		
			1/4(0.25)	J (±5%)	400±200	0.1 to 0.13		
					±250	0.15 to 0.91		
				F (±1%)	500±300	0.047 to 0.091		
					400±200	0.1 to 0.13		
			1/2(0.5)	J (±5%)	±250	0.15 to 9.1		
					300±300	0.047 to 0.091		
				F (±1%)	±200	0.1 to 0.91		
					300±300	0.047 to 0.091		
			1/2(0.5)	J (±5%)	±200	0.1 to 9.1		
					500±300	0.047 to 0.091		
				F (±1%)	400±200	0.1 to 0.13		-55 to +125
					±250	0.15 to 9.1		
			1	J (±5%)	500±300	0.047 to 0.091		
					400±200	0.1 to 0.13		
		F (±1%)		±250	0.15 to 0.91			
				500±300	0.047 to 0.091			
				400±200	0.1 to 0.13			
				±250	0.15 to 9.1			
Thick Film Low Ohmic Chip Resistors <UCR Series>								
★ UCR01	1005 (0402)		0.125	J (±5%)	0 to 300	68m to 910m	-55 to +155	
				F (±1%)				
★ UCR03	1608 (0603)		0.2	J (±5%)	0 to 250	20m to 910m		
				F (±1%)				
			0.33	J (±5%)	250±200/0 to 250/0 to 150	11m to 100m		
				F (±1%)	0 to 250/0 to 150	20m to 100m		
			0.5	J (±5%)	0 to 350/0 to 200/0 to 150	11m to 100m		
				F (±1%)	0 to 350/0 to 200/0 to 150			

★ : Under development

* : The temperature characteristics will vary depending on the resistance value

Part No.	Size (inch)	Circuit	Rated power (W)	Tolerance	Temperature coefficient (ppm/°C)	Resistance range (Ω)	Operating temperature range (°C)	
Ultra-low Ohmic Chip Resistors for Current Detection <PMR Series>								
PMR03	1608 (0603)		0.25	J (±5%)	±150	10m	-55 to +155	
				F (±1%)				
PMR10	2012 (0805)		0.5	J (±5%)	±150	2m, 3m, 4m, 5m, 6m, 7m, 8m, 9m, 10m		
				G (±2%)				
				0.75	J (±5%)	±150		
			F (±1%)					
PMR18	3216 (1206)		1	J (±5%)	±100	1m, 2m, 3m, 4m, 5m		
		F (±1%)						
PMR25	3225 (1210)	1	J (±5%)	±100	1m, 2m, 3m, 4m, 5m, 6m, 7m, 8m, 9m, 10m			
			F (±1%)					
PMR50	5025 (2010)	2	J (±5%)	±100*				
			F (±1%)					
PMR100	6432 (2512)							
Ultra-low Ohmic Wide Terminal Chip Resistors <PML Series>								
★ PML50	5025 (2010)		2	J (±5%)	±200	0.5m, 1m, 1.5m, 2m, 2.2m	-55 to +155	
★ PML100	6432 (2512)		3	J (±5%)	±200			
High Power Wide Terminal Chip Resistors (Low Ohmic Type) <LTR Series>								
LTR10	2012 (0805)		0.5	J (±5%)				
				F (±1%)				
★ LTR18	3216 (1206)		0.75	J (±5%)	±150	47m to 9.1	-55 to +155	
		F (±1%)						
★ LTR50	5025 (2010)	1.25	J (±5%)					
				F (±1%)				
High Power Wide Terminal Chip Resistors <LTR Series>								
LTR10	2012 (0805)		0.25	J (±5%)	±200	1 to 1M	-55 to +155	
				F (±1%)	±100	10 to 1M		
				D (±0.5%)				
LTR18	3216 (1206)		0.5	J (±5%)	±200	1 to 1M		
				F (±1%)	±100	10 to 1M		
				D (±0.5%)				
LTR50	5025 (2010)	1	J (±5%)	±200	1 to 1M			
			F (±1%)	±100	10 to 130k			
			D (±0.5%)					

★ : Under development

* : 1mΩ and 2mΩ only : ±150ppm/°C

Low Ohmic Lineup Distribution Chart

Rated Power - Size

Rated power (W)	0.063	0.1	0.125	0.2	0.25	0.33	0.5	0.75	1	1.25	1.5	2
6432												
5025												
3225												
3216												
2012												
1608												
1005												

Resistance Value - Size (Less than 10Ω)

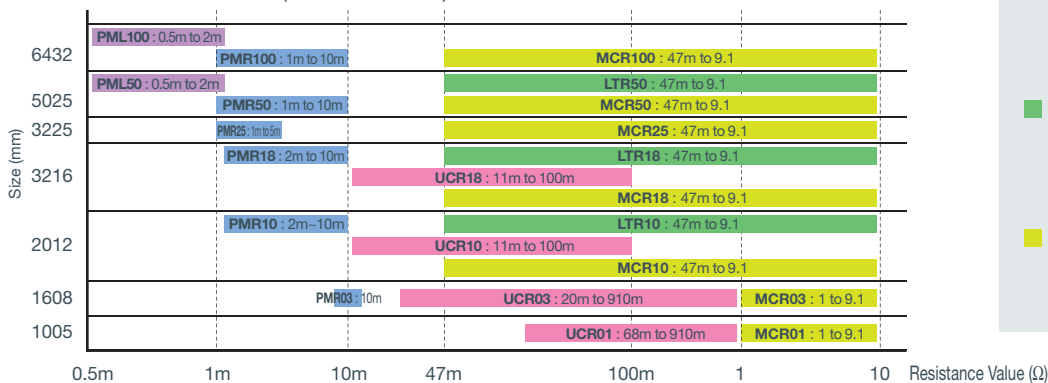

- Ultra-low Ohmic Chip Resistors for Current Detection
PMR Series
- Ultra-low Ohmic Wide Terminal Chip Resistors
PML Series
- Thick Film Low Ohmic Chip Resistors
UCR Series
- High Power Wide Terminal Chip Resistors (Low Ohmic Type)
LTR Series
- Standard Chip Resistors (Low Ohmic Type)
MCR Series

Part No.	Size (inch)	Circuit	Rated power (W)	Tolerance	Temperature coefficient (ppm/°C)	Resistance range (Ω)	Operating temperature range (°C)		
Anti-surge Chip Resistors <ESR Series>									
ESR03	1608 (0603)		0.2	±200	J (±5%)	1 to 10M	-55 to +155		
				±100	F (±1%)				
ESR10	2012 (0805)		0.25	±200	J (±5%)	1 to 10M			
				±100	F (±1%)				
ESR18	3216 (1206)		0.33	±200	J (±5%)	1 to 10M			
				±100	F (±1%)				
ESR25	3225 (1210)		0.5	±200	J (±5%)	1 to 10M			
				±100	F (±1%)				
High Voltage Resistance Chip Resistors <KTR Series>									
KTR03	1608 (0603)			0.1	±200	J (±5%)		1 to 10M	-55 to +155
		±100			F (±1%)				
KTR10	2012 (0805)	0.125		±200	J (±5%)	1 to 10M			
				±100	F (±1%)				
KTR18	3216 (1206)	0.25		±200	J (±5%)	1 to 10M			
				±100	F (±1%)				
KTR25	3225 (1210)	0.33		±200	J (±5%)	1 to 10M			
				±100	F (±1%)				
Sulfur-resistant Chip Resistors <TRR Series>									
TRR01	1005 (0402)		0.063	+500/-250/±200 *	J (±5%)	1 to 10M	-55 to +155		
				±100	F (±1%)				
TRR03	1608 (0603)		0.1	±400/±200 *	J (±5%)	1 to 10M			
				±100	F (±1%)				
TRR10	2012 (0805)		0.125	±400/±200 *	J (±5%)	1 to 10M			
				±100	F (±1%)				
TRR18	3216 (1206)		0.25	±400/±200 *	J (±5%)	1 to 10M			
				±100	F (±1%)				
Compact Chip Resistor Networks <MNR Series>									
MNR02	1005 × 2		0.063 / Element	±300	J (±5%)	10 to 1M	-55 to +125		
MNR12	1608 × 2		0.063 / Element	±200	J (±5%)				
MNR32	3216 × 2		0.125 / Element	±200	J (±5%)	10 to 1M	-55 to +125		
MNR04	1005 × 4		0.063 / Element	±200	J (±5%)				
MNR14	1608 × 4		0.063 / Element	±200	J (±5%)				
MNR34	3216 × 4		0.125 / Element	±200	J (±5%)				
Compact 8-element Chip Resistor Networks <MNR Series>									
MNR15	1608 × 5		0.031 / Element	±200	J (±5%)	56 to 100k	-55 to +125		
MNR35	3216 × 5		0.063 / Element	±200	J (±5%)	56 to 100k			
MNR18	1605 × 8		0.063 / Element	±200	J (±5%)	10 to 1M			
Chip Attenuators <RCN Series>									
Part No.	Size (inch)	Circuit	No. of pins	No. of elements	Rated power (W)	Impedance (Ω)	Voltage standing wave ratio	Operating temperature range (°C)	
RCN02	1010 (0402)		4	3	0.04 / Package	50	Less than 1.3	-55 to +125	
Narrow Pitch Paper Tape Chip Resistors									
Part No.	Size (inch)	Pitch (Taping)	Minimum Order Quantity						
MCR03MZPJ	1608(0603)	2mm	10,000 pcs.						
MCR03MZPFX									
1608-sized EMI Filters <MCF Series>									
Part No.	Size (inch)	Circuit	Rated current (A)	Capacitance tolerance	Capacitance (pF)	Operating temperature range (°C)			
MCF18	1608 (0603)		4	M (±20%)	1,000 to 100,000	-55 to +125			
					1,000,000	-55 to +85			
					★ 220,000 to 470,000	-55 to +85			

★ : Under development

* : The temperature characteristics will vary depending on the resistance value

Thick Film Low Ohmic Chip Resistors



UCR Series (11mΩ~)

Summary

Thick film resistive elements were used to create this lineup of ultra-low resistance products ranging from 10mΩ to 100mΩ. Ideal for current detection.

Features

- Compact
- High performance

Applications

- Notebook PCs, mobile phones, HDDs, portable audio players, power supplies, motors, and more

Resistance changes minimized

The rear-mount structure prevents changes in the resistance value during mounting.

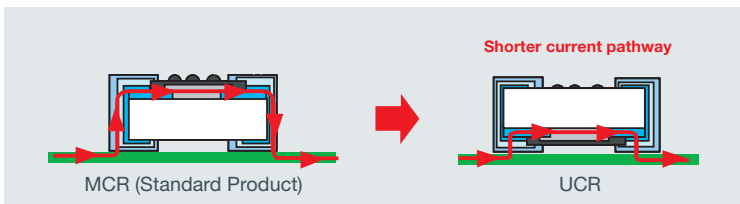

Stable, low resistance characteristics guaranteed - regardless of ambient conditions

Comparison of the resistance change rate between the UCR series and general-purpose products

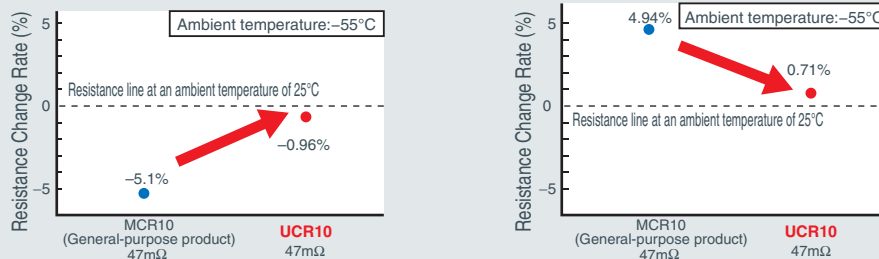

Lineup

Part No.	Size (inch)	Circuit	Rated power (W)	Tolerance	Temperature coefficient (ppm/°C)	Resistance range (Ω)	Operating temperature range (°C)
★ UCR01	1005 (0402)		0.125	J (±5%)	0 to 300	68m to 910m	
				F (±1%)			
★ UCR03	1608 (0603)		0.2	J (±5%)	0 to 250	20m to 910m	
				F (±1%)			
UCR10	2012 (0805)		0.33	J (±5%)	250±200	11m to 18m	
					0 to 250	20m to 47m	
				F (±1%)	0 to 150	51m to 910m	
					0 to 250	20m to 47m	
UCR18	3216 (1206)		0.5		0 to 150	51m to 910m	
					0 to 350	11m to 18m	
		J (±5%)		0 to 200	20m to 39m		
				0 to 150	43m to 100m		
		F (±1%)		0 to 350	11m to 18m		
				0 to 200	20m to 39m		
			0 to 150	43m to 100m			

★ : Under development

* The designs and specifications are subject to change without notice

Ultra-low Ohmic Chip Resistors for Current Detection

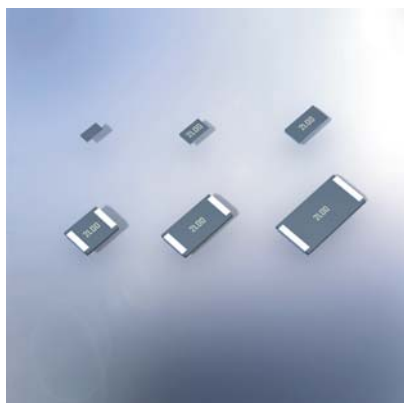

PMR Series (1mΩ~)

Summary

These ultra-low ohmic chip resistors utilize ROHM's original structural design for improved current detection precision. A full lineup is available in resistances ranging from 1mΩ to 10mΩ.

Features

- High power

Applications

- Current detection sets
- Notebook PCs, HDDs, mobile phones, DC/DC converters, automotive systems, and more

Unique trimless structure

- Ideal for high-speed switching circuits
- Excellent heat dissipation characteristics
- Stable operation, even under extreme temperature fluctuations

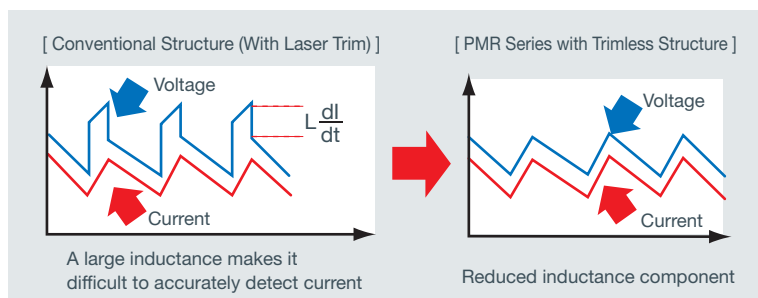

Superior Resistance-Temperature Characteristics

- Stable resistance temperature characteristics

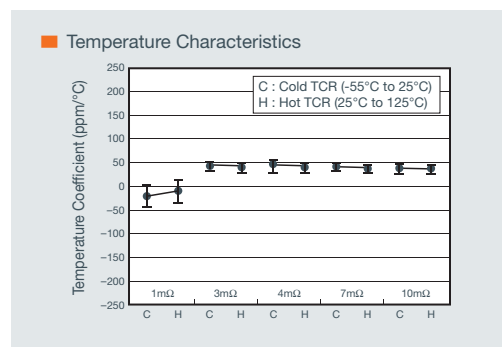

Circuit Example

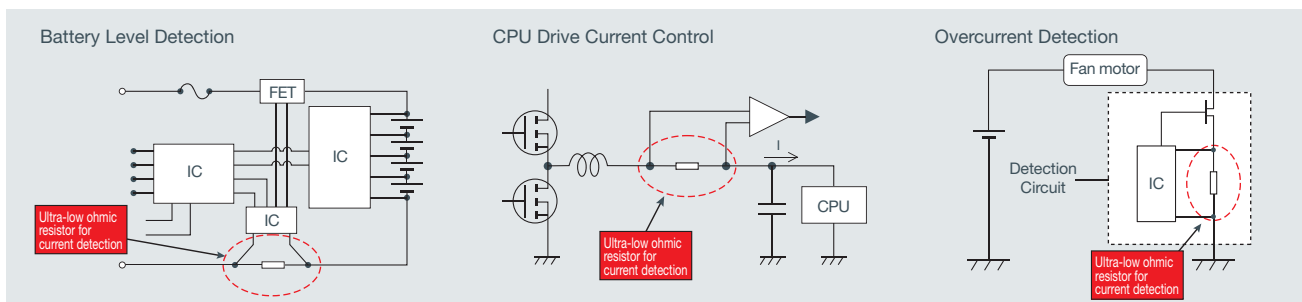

Lineup

Part No.	Size (inch)	Circuit	Rated power (W)	Tolerance	Temperature coefficient (ppm/°C)	Resistance range (Ω)	Operating temperature range (°C)
PMR03	1608 (0603)		0.25	J (±5%)	±150	10m	-55 to +155
				F (±1%)			
PMR10	2012 (0805)		0.5	J (±5%)	±150	2m, 3m, 4m, 5m, 6m, 7m, 8m, 9m, 10m	
				F (±1%)			
PMR18	3216 (1206)		0.75	J (±5%)	±150		
			F (±1%)				
PMR25	3225 (1210)		1	J (±5%)	±100	1m, 2m, 3m, 4m, 5m	
			F (±1%)				
PMR50	5025 (2010)		1	J (±5%)	±100	1m, 2m, 3m, 4m, 5m, 6m, 7m, 8m, 9m, 10m	
			F (±1%)				
PMR100	6432 (2512)		2	J (±5%)	±100 *		
				F (±1%)			

*1mΩ and 2mΩ only: ±150ppm/°C

Ultra-low Ohmic Wide Terminal Chip Resistors for Current Detection

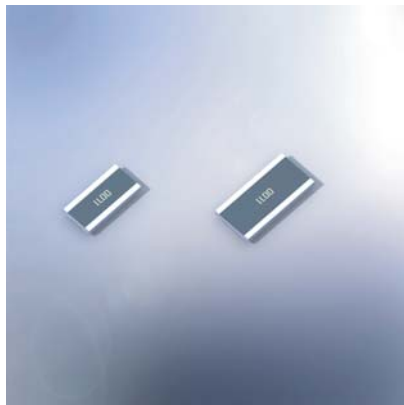

PML Series (0.5mΩ~)

Summary

ROHM's ultra-low ohmic wide terminal chip resistors utilize a proprietary design for improved current detection accuracy. Available in a range of resistances, from 0.5mΩ to 2.2mΩ.

Features

- High performance
- High reliability

Applications

- Automotive (i.e. power steering, ECU)
- Current detection in large current motors

Wide terminal configuration improves reliability

- Improved heat dissipation.
- Higher rated power (3W guaranteed in the 6432 size)
- Wider contact area with the mounting plate provides a more reliable connection. Ideal for vehicle applications exposed to temperature cycling / fluctuations.

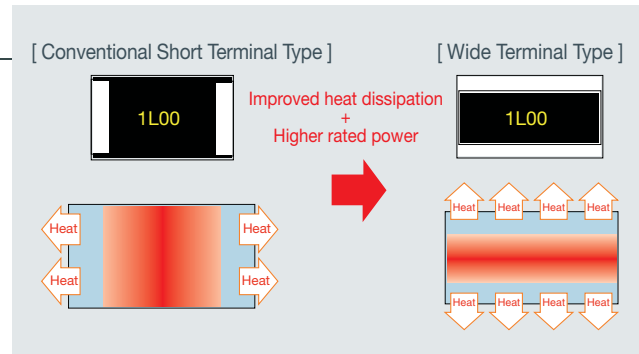

Application Examples

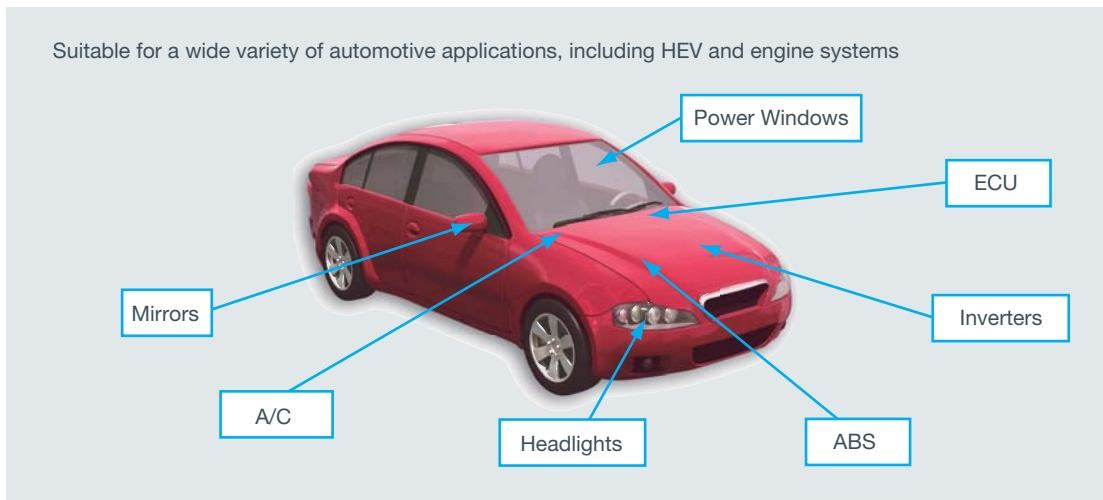

Lineup

Part No.	Size (inch)	Circuit	Rated power (W)	Tolerance	Temperature coefficient (ppm/°C)	Resistance range (Ω)	Operating temperature range (°C)
★ PML50	5025 (2010)	R	2	J (±5%)	±200	0.5m, 1m, 1.5m, 2m, 2.2m	-55 to +155
★ PML100	6432 (2512)		3	J (±5%)	±200		

★ : Under development

*The designs and specifications are subject to change without notice

High Power Wide Terminal Chip Resistors (Low Ohmic Type)



LTR Series (47mΩ~)

Summary

ROHM's novel heat dissipation design ensures higher rated power. The broad lineup ranges from 47mΩ to 9.1Ω.

Features

- High performance
- High reliability

Applications

- Automotive systems
- PCs, HDDs, and other devices requiring current detection

The industry's highest rated power

- Original heat dissipation design ensures higher power handling capability

Rated Power

Size	General-purpose MCR Series	LTR Series
2012	0.25W	0.5W (2x)
3216	0.25W	0.75W (3x)
5025	0.5W	1.25W (2.5x)

Excellent temperature cycling resistance

- Optimized design results in lower TCR than conventional products

[Example]

MCR (47mΩ) 500±300ppm/°C
 ↓
 LTR (47mΩ) ±150ppm/°C

Temperature Coefficient

Size	General-purpose MCR Series	LTR Series
5025	500±300 (0.047 to 0.091Ω)	±150 (Improved TCR)
3216	400±200 (0.1 to 0.13Ω)	
2012	±250 (0.15 to 9.1Ω)	

Rear-mount structure

The rear-mount structure minimizes resistance changes during mounting. Rated power is also significantly improved.

(Top view) (Side view)



Lineup

Part No.	Size (inch)	Circuit	Rated power (W)	Tolerance	Temperature coefficient (ppm/°C)	Resistance range (Ω)	Operating temperature range (°C)
LTR10	2012 (0805)		0.5	J (±5%)	±150	47m to 9.1	-55 to +155
★ LTR18	3216 (1206)			F (±1%)			
★ LTR50	5025 (2010)		J (±5%)				
			F (±1%)				
			F (±1%)				

★ : Under development

* The designs and specifications are subject to change without notice

High Power Wide Terminal Chip Resistors

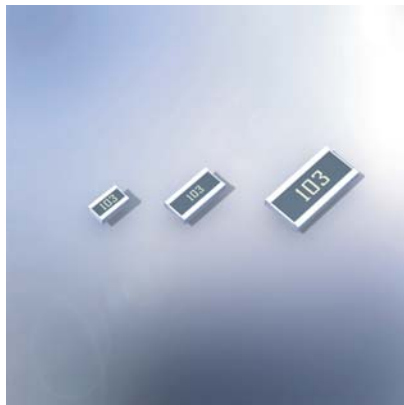

LTR Series

Summary

Making the long side of the resistor the electrode reduces the distance between the electrodes, improving temperature cycling strength.

Features

- Strong against surges
- High reliability

Applications

- Automotive systems, HDDs, and more

Superior connection reliability against thermal cycling

- Outstanding junction reliability characteristics against heat cycling.
- The LTR series is highly resistant to soldering cracks caused by thermal stress.

	Wide Terminal LTR Series	General-purpose MCR Series
Distance Between Electrodes	Short	Long
Effects of PCB Expansion/Contraction	Mechanical stress on junction area small	Mechanical stress on junction area large
Junction Reliability	Very good	Good

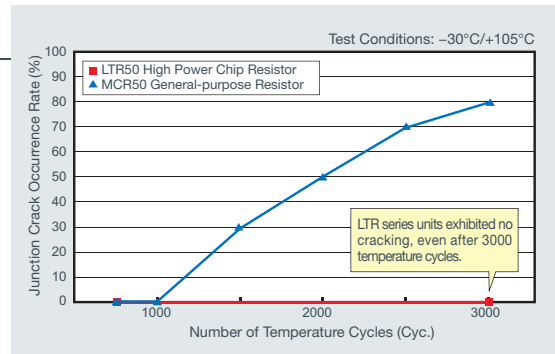

3kV* electrostatic discharge resistance (*EIAJ4710-1 Human Body Model)

ROHM's unique resistive element structure and trimming design ensure greatly improved surge resistance characteristics. Only ROHM guarantees an electrostatic discharge resistance of 3kV (wide terminal type).

High Power Chip Resistors (Wide Terminal Type) vs. General-purpose Chip Resistors (MCR Series)

<2012 Size>

<3216 Size>

<5025 Size>

	LTR10/LTR18	LTR50
DCV (Applied Voltage)	3kV	5kV
No. of Cycles	±10times	±10times
C (Capacitance)	100 pF	100 pF
R1 (Discharge Resistance)	1.5kΩ	1.5kΩ

Significantly higher rated power

Higher rated power makes it possible to use smaller resistors.

	LTR Series	MCR Series
2012	0.25	0.125
3216	0.5	0.25
5025	1	0.5
6432	-	1

Lineup

Part No.	Size (inch)	Circuit	Rated power (W)	Tolerance	Temperature coefficient (ppm/°C)	Resistance range (Ω)	Operating temperature range (°C)
LTR10	2012 (0805)		0.25	J (±5%)	±200	1 to 1M	
				F (±1%)	±100		
				D (±0.5%)	±100		
LTR18	3216 (1206)		0.5	J (±5%)	±200	1 to 1M	-55 to +155
				F (±1%)	±100		
				D (±0.5%)	±100		
LTR50	5025 (2010)		1	J (±5%)	±200	1 to 1M	
				F (±1%)	±100		
				D (±0.5%)	±100		

Anti-surge Chip Resistors

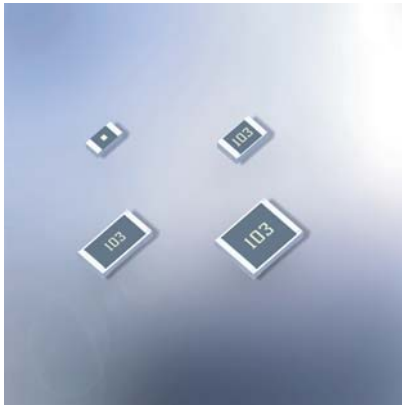

ESR Series

Summary

Significantly improved anti-surge characteristics have been achieved due to utilization of original resistor construction and trimming processes.

Features

- Small
- Surge-resistant

Applications

- Electronic devices requiring anti-surge and anti-pulse characteristics.

3kV* electrostatic discharge resistance

(*EIAJ4701-1 Human Body Model)

An electrostatic discharge resistance of 3kV has been achieved using novel construction and trimming processes, resulting in a greater degree of reliability.

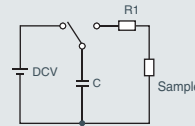

	ESR03/10/18	ESR25
DCV (Applied Voltage)	3kV	5kV
No. of Cycles	±10 times	±10 times
C (Capacitance)	100 pF	100 pF
R1 (Discharge Resistance)	1.5kΩ	1.5kΩ

Significant improvement in endurance surge characteristics

Anti-surge Chip Resistors (ESR Series) vs. Conventional Chip Resistors (MCR Series)

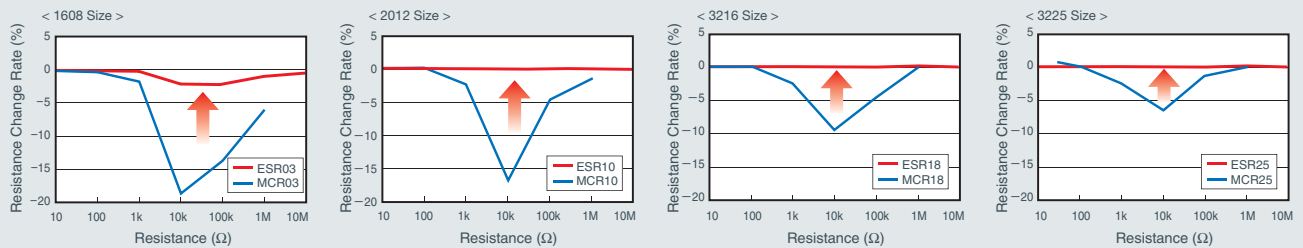

Double the conventional rated power

Significantly improved voltage resistance characteristics have been achieved through utilization of original resistive element structure and trimming design.

Only ROHM guarantees 0.2W in the 1608 size.

A higher rated power enables smaller resistors to be used, saving space.

	ESR Series	General-purpose MCR Series
1608	0.2W	0.1W
2012	0.25W	0.125W
3216	0.33W	0.25W
3225	0.5W	0.25W
5025	-	0.5W

Downsizing

Lineup

Part No.	Size (inch)	Circuit	Rated power (W)	Tolerance	Temperature coefficient (ppm/°C)	Resistance range (Ω)	Operating temperature range (°C)
ESR03	1608 (0603)		0.2	J (±5%)	±200	1 to 10M	-55 to +155
				F (±1%)	±100		
ESR10	2012 (0805)		0.25	J (±5%)	±200	1 to 10M	
				F (±1%)	±100		
ESR18	3216 (1206)		0.33	J (±5%)	±200	1 to 10M	
				F (±1%)	±100		
ESR25	3225 (1210)	0.5	J (±5%)	±200	1 to 10M		
			F (±1%)	±100			
				D (±0.5%)	±100	10 to 1M	

High Voltage Resistance Chip Resistors

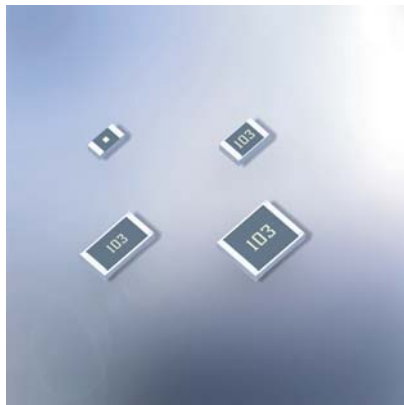

KTR Series

Summary

High voltage characteristics (more than double that of conventional products) have been achieved through the use of proprietary construction and trimming processes.

Features

- Compact
- High voltage

Applications

- Camera flash circuits
- Inverter circuits
- Power supplies

High voltage resistance

ROHM's unique resistance pattern and trimming design prevent concentration of the voltage load, resulting in more than twice the voltage resistance of our own general-purpose products (MCR series).

High voltage resistance circuits requiring multiple resistors can reduce the number of components by replacing conventional chip resistors with KTR series units. They are ideal for mobile products, which are becoming increasingly compact and thin.

[Limiting Element Voltage]

The rated voltage is defined as the maximum voltage that can be applied continuously and is calculated using the following equation:

$$\text{Rated Voltage (V)} = \sqrt{\text{Rated Power (W)} \times \text{Nominal Resistance (\Omega)}}$$

Note that the limiting element voltage of the element should not to be exceeded.

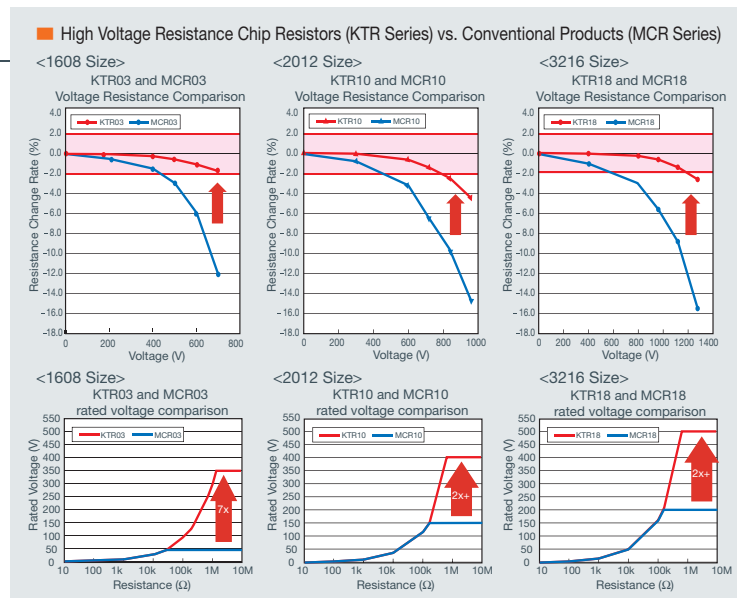

Circuit Examples

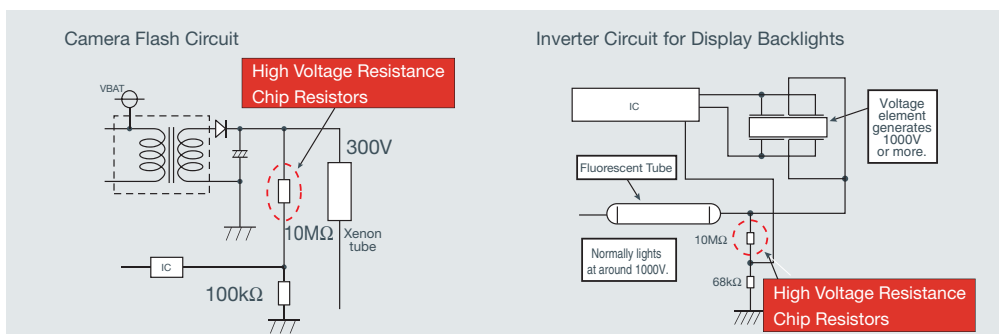

Lineup

Part No.	Size (inch)	Circuit	Rated power (W)	Limiting element voltage (V)	Tolerance	Temperature coefficient (ppm/°C)	Resistance range (Ω)	Operating temperature range (°C)
KTR03	1608 (0603)		0.1	350	J (±5%) F (±1%)	±200 ±100	1 to 10M	-55 to +155
KTR10	2012 (0805)		0.125	400	J (±5%) F (±1%)	±200 ±100	1 to 10M	
KTR18	3216 (1206)		0.25	500	J (±5%) F (±1%)	±200 ±100	1 to 10M	
KTR25	3225 (1210)		0.33	600	J (±5%) F (±1%)	±200 ±100	1 to 10M	

Sulfur-resistant Chip Resistors

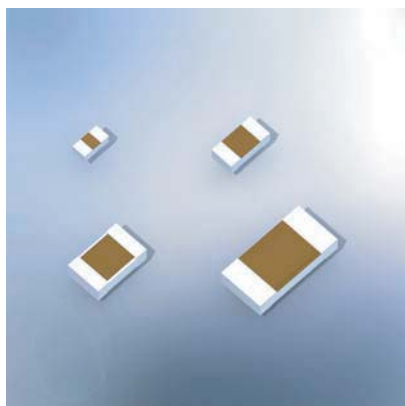

TRR Series

Summary

The special internal structure prevents sulfurated gases from entering, resulting in greater reliability and stabler operation in sulfur-rich environments compared to general-purpose products.

Features

- High reliability

Applications

- Circuits exposed to sulfur-rich environments, such as those in automotive systems.

Reliable in sulfurated environments

Until now, resistors were particularly susceptible to failure in sulfur-rich environments. In response to this, ROHM's offers the TRR series featuring an internal structure resistant to silver migration and the formation of silver sulfide, resulting in a greater level of reliability.

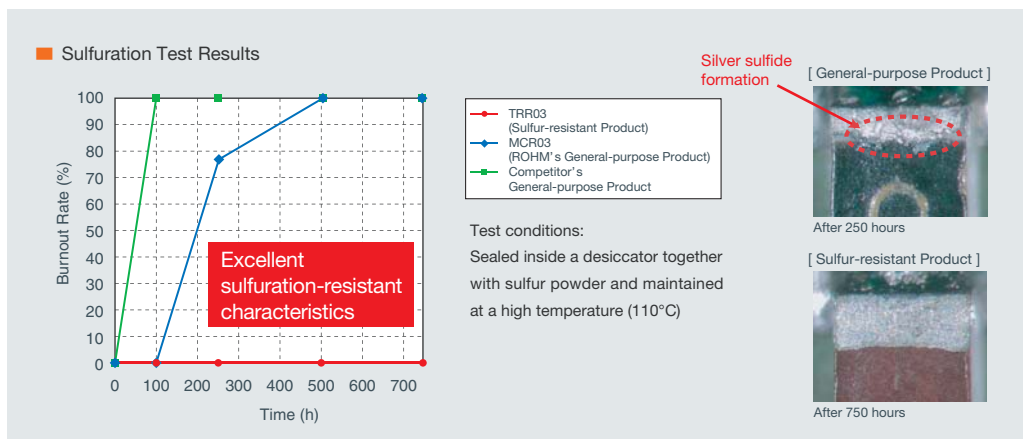

Lineup

Part No.	Size (inch)	Circuit	Rated power (W)	Tolerance	Temperature coefficient (ppm/°C)	Resistance range (Ω)	Operating temperature range (°C)
TRR01	1005 (0402)		0.063	J (±5%)	+500/-250	1 to 9.1	-55 to +155
				F (±1%)	±200	10 to 10M	
TRR03	1608 (0603)		0.1	J (±5%)	±400	1 to 9.1	
				F (±1%)	±100	10 to 10M	
TRR10	2012 (0805)		0.125	J (±5%)	±400	1 to 9.1	
				F (±1%)	±100	10 to 10M	
TRR18	3216 (1206)	0.25	J (±5%)	±400	1 to 9.1		
			F (±1%)	±100	10 to 10M		

Also compatible with jumpers.

0402-sized Ultra-compact Chip Resistors

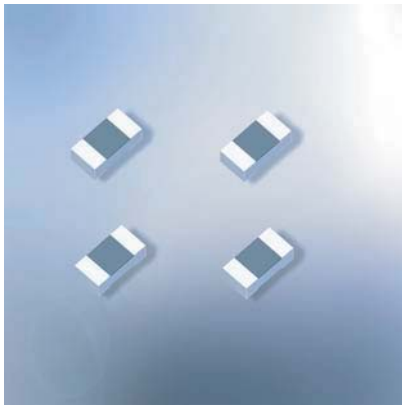

MCR004 Series

Summary

ROHM's 0402 sized ultra-compact chip resistors are the smallest in the world, contributing to increased space savings in mobile devices and module products.

Features

- Compact
- Space-saving

Applications

- Modules
- Portable audio
- Mobile phones
- Digital cameras

Lightweight · Space-saving

Surface area is reduced by 56% compared to the MCR006 (0603) and MCR004 (0402) package types, respectively, ensuring suitability with compact, cutting-edge applications.

Smaller footprint saves space, contributing to greater miniaturization

Example:

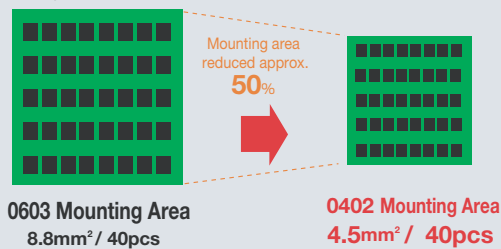

High dimensional precision

Ultra-compact chip resistors in the 0402 and 0603 size require more precise process technologies (compared to conventional processes) in order to ensure high dimensional accuracy.

Precision semiconductor processing technology utilized for high dimensional accuracy



Press carrier tape applications

Press carrier tape is used in order to reduce failures during the mounting process.

— Press Carrier Tape Features —

- No adhesive substance on the bottom of the pocket (bottom tape not used).
- Highly precise pocket position.

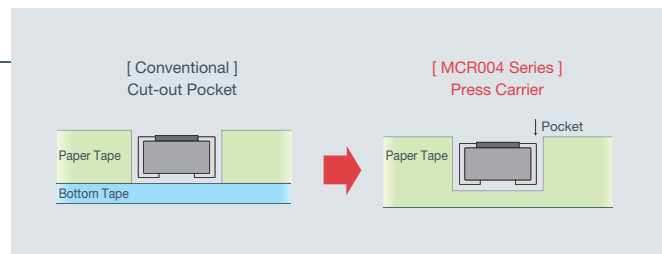

Lineup

Part No.	Size (inch)	Circuit	Rated power (W)	Tolerance	Resistance range (Ω)	Resistance range (Ω)	Operating temperature range (°C)
New MCR004	0402 (01005)		0.031	J (±5%) F (±1%)	±250	10 to 3M	-55 to +125

Also compatible with jumpers.

<Taping specifications>

Part No.	Taping No.	Taping specs	Min. order quantity (pcs)
MCR004	YZP	Paper tape (2mm pitch)	15,000
	New RZP	Embossed tape (1mm pitch)	40,000

Narrow Pitch Paper Tape Products

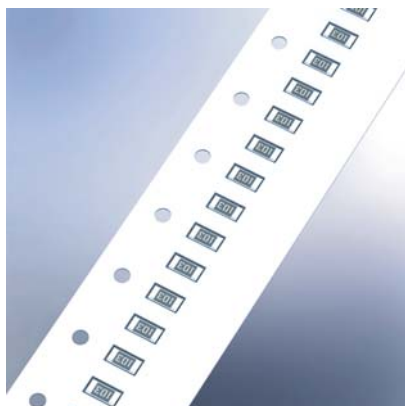

MCR03MZP Series

Summary

The pitch is half that of standard products, resulting in double the quantity per reel in the same reel size (φ180mm).

Features

- Halves the number of reel changes
- Cuts the amount of packaging waste by 50%

Applications

- All products

Doubles the time between reel replacement. Cuts package waste in half.



No new equipment required · Easy to install

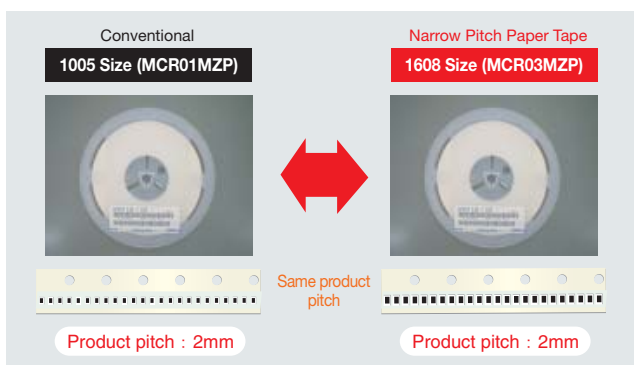

Improves productivity by halving the number of reel replacements

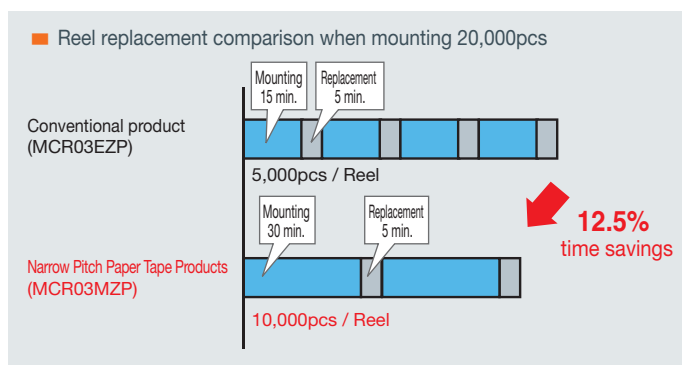

Lineup

Part No.	Size (inch)	Product Pitch (Taping)	Reel
MCR03MZPJ	1608 (0603)	2mm	10,000 pcs.
MCR03MZPFX			
MCR03MZPD			

1608-sized EMI Filters

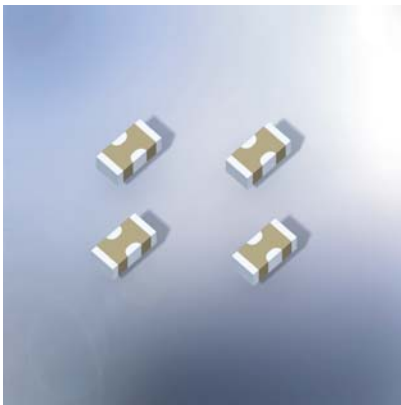

MCF18 Series

Summary

Industry's smallest size (1608)
 Entire series compatible with large currents (4A).

Features

- Compact
- High performance

Applications

- Digital TVs, DVDs, digital camcorders
- Mobile phones
- Copiers and more

High performance

The amount of attenuation in high frequency bands is vastly improved compared to two-terminal capacitors, resulting in greater noise removal efficiency. The number of parts required is reduced as well.

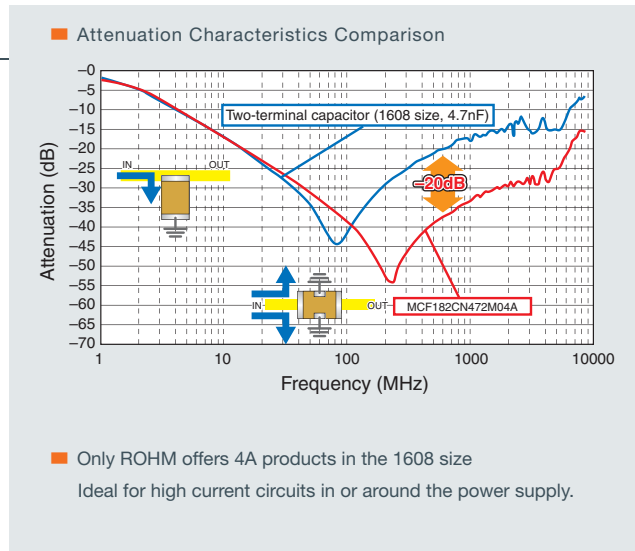

Internal resistance is lower than in standard products (competitors' 2A units)

1. Decreased line-side voltage
2. Reduced heat generation due to energization

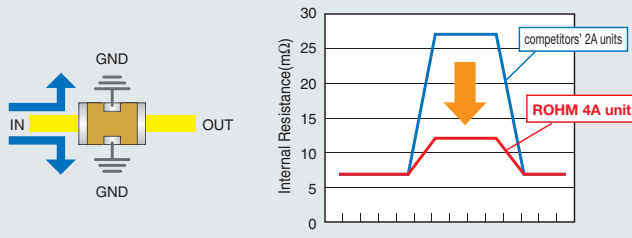

Circuit Examples

Ideal for noise reduction on large current power lines

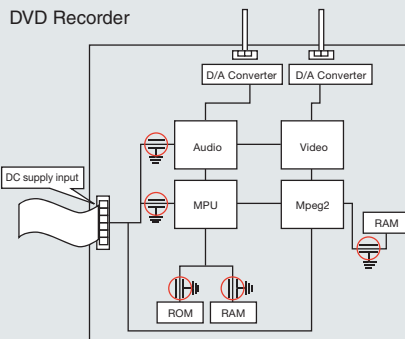
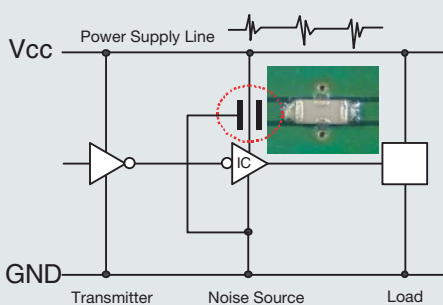

Lineup

Part No.	Size (inch)	Circuit	Rated current (A)	Capacitance Tolerance	Capacitance (pF)	Operating temperature range (°C)
MCF18	1608 (0603)		4	M (±20%)	1,000 to 100,000	-55 to +125
					1,000,000	-55 to + 85
					★ 220,000 to 470,000	-55 to + 85

★ : Under development

* : The designs and specifications are subject to change without notice

Dimensions

Unit : mm

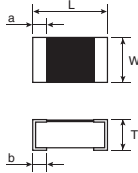
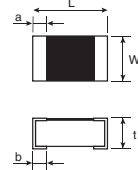
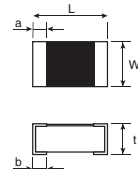
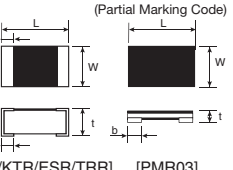
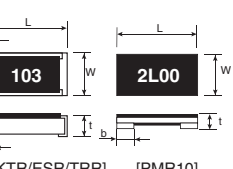
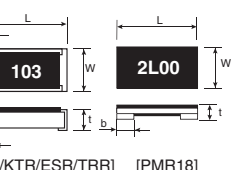
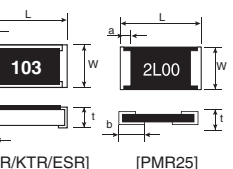
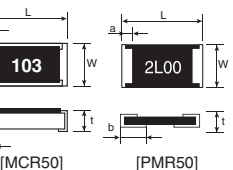
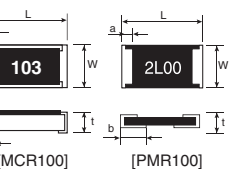
Dimensions	Series	L	W	t	a	b
0402 (01005) 	MCR004	0.4±0.02	0.2±0.02	0.13±0.02	0.1±0.03	0.1±0.03
0603 (0201) 	MCR006	0.6±0.03	0.3±0.03	0.23±0.03	0.1±0.05	0.15±0.05
1005 (0402) 	MCR01	1.0±0.05	0.5±0.05	0.35±0.05	0.2±0.1	0.25 ^{+0.05} _{-0.1}
	TRR01				0.33±0.08	
1608 (0603)  [MCR/KTR/ESR/TRR] [PMR03]	MCR03	1.6±0.1	0.8±0.1	0.45±0.1	0.3±0.2	0.3±0.2
	KTR03				0.4±0.1	
	ESR03					
	TRR03	PMR03	1.6±0.15	0.8±0.15	0.25±0.15	—
2012 (0805)  [MCR/KTR/ESR/TRR] [PMR10]	MCR10	2.0±0.1	1.25±0.1	0.55±0.1	0.4±0.2	0.4±0.2
	KTR10				0.3±0.2	
	ESR10					
	TRR10	PMR10	2.0±0.15	1.2±0.15	0.42 to 0.28° ±0.15	0.43 ^{+0.15} _{-0.1}
3216 (1206)  [MCR/KTR/ESR/TRR] [PMR18]	MCR18	3.2±0.15	1.6±0.15	0.55±0.1	0.5±0.25	0.5±0.25
	KTR18				0.3±0.25	
	ESR18					
	TRR18	PMR18	3.2±0.15	1.6±0.15	0.42 to 0.28° ±0.15	0.69 ^{+0.20} _{-0.15}
3225 (1210)  [MCR/KTR/ESR] [PMR25]	MCR25	3.2±0.15	2.5±0.15	0.55±0.15	0.5±0.25	0.5±0.25
	KTR25				0.3±0.25	
	ESR25					
	PMR25	3.2±0.2	2.5±0.2	0.52 to 0.32° ±0.15	0.5±0.2	1.2 to 0.5° ±0.2
5025 (2010)  [MCR50] [PMR50]	MCR50	5.0±0.15	2.5±0.15	0.55±0.15	0.6±0.25	0.6±0.25
	PMR50	5.0±0.2	2.5±0.2	0.52 to 0.32° ±0.15	0.5±0.2	1.9 to 0.9° ±0.2
6432 (2512)  [MCR100] [PMR100]	MCR100	6.3±0.15	3.2±0.15	0.55±0.15	0.6±0.25	0.6±0.25
	PMR100	6.4±0.25	3.2±0.25	0.52 to 0.32° ±0.15	0.5±0.25	2.3 to 1.1° ±0.25

Note: Numbers in () indicate the size in inches

*May vary depending on the resistance value. For additional details, please consult with a local sales representative.

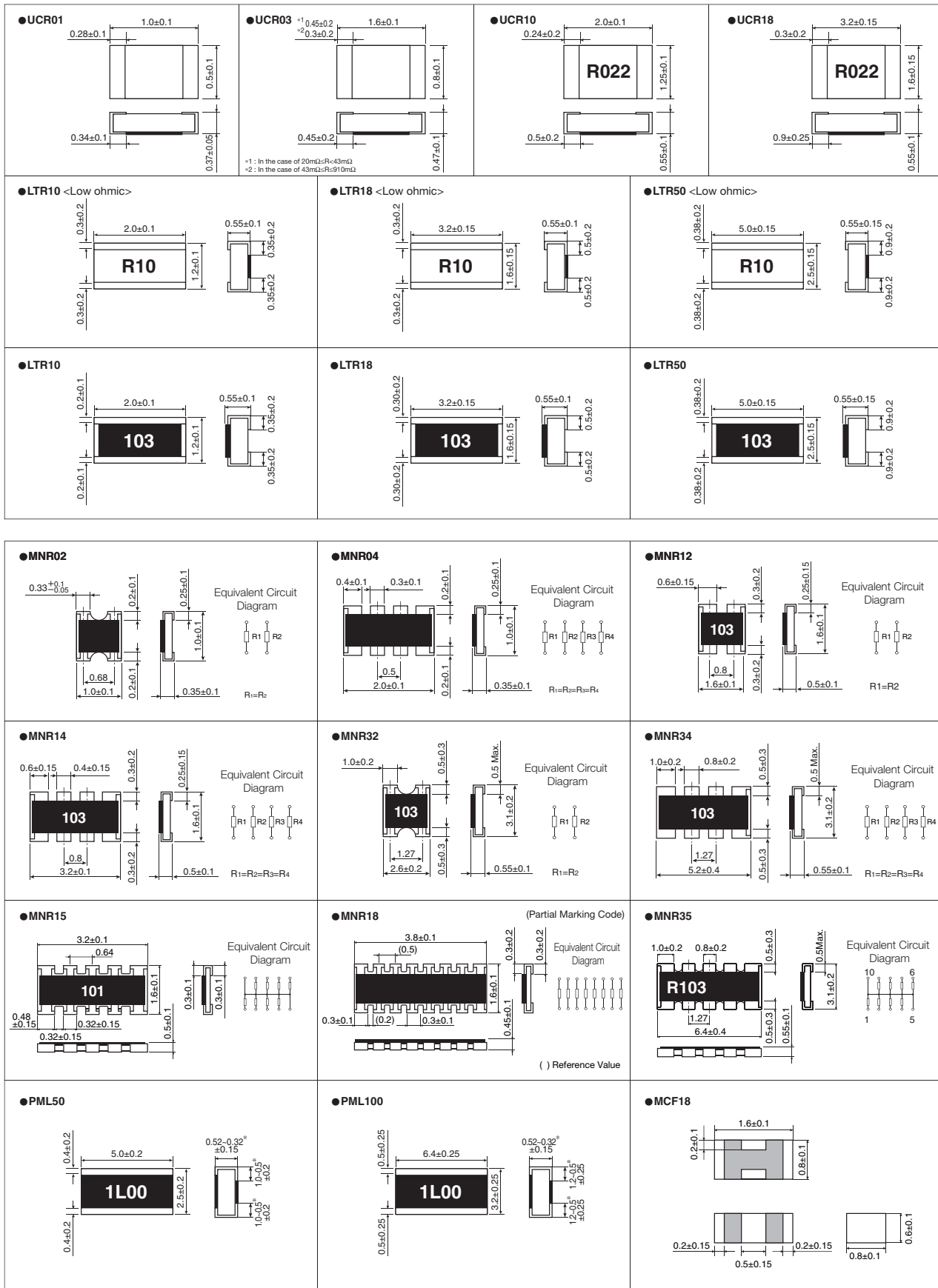

* May vary depending on the resistance value. For additional details, please consult with a local sales representative.

The content specified in this document is correct as of 1st June, 2009.

No copying or reproduction of this document, in part or in whole, is permitted without the consent of ROHM Co.,Ltd.

The content specified herein is subject to change for improvement without notice.

The content specified herein is for the purpose of introducing ROHM's products (hereinafter "Products"). If you wish to use any such Product, please be sure to refer to the specifications, which can be obtained from ROHM upon request. Examples of application circuits, circuit constants and any other information contained herein illustrate the standard usage and operations of the Products. The peripheral conditions must be taken into account when designing circuits for mass production.

Great care was taken in ensuring the accuracy of the information specified in this document. However, should you incur any damage arising from any inaccuracy or misprint of such information, ROHM shall bear no responsibility for such damage.

The technical information specified herein is intended only to show the typical functions of and examples of application circuits for the Products. ROHM does not grant you, explicitly or implicitly, any license to use or exercise intellectual property or other rights held by ROHM and other parties. ROHM shall bear no responsibility whatsoever for your use of any Product outside of the prescribed scope or not in accordance with the instruction manual.

The Products specified in this document are intended to be used with general-use electronic equipment or devices (such as audio visual equipment, office-automation equipment, communication devices, electronic appliances and amusement devices).

The Products specified in this document are not designed to be radiation tolerant.

While ROHM always makes efforts to enhance the quality and reliability of its Products, a Product may fail or malfunction for a variety of reasons.

Please be sure to implement in your equipment using the Products safety measures to guard against the possibility of physical injury, fire or any other damage caused in the event of the failure of any Product, such as derating, redundancy, fire control and fail-safe designs. ROHM shall bear no responsibility whatsoever for your use of any Product outside of the prescribed scope or not in accordance with the instruction manual.

The Products are not designed or manufactured to be used with any equipment, device or system which requires an extremely high level of reliability the failure or malfunction of which may result in a direct threat to human life or create a risk of human injury (such as a medical instrument, transportation equipment, aerospace machinery, nuclear-reactor controller, fuel-controller or other safety device). ROHM shall bear no responsibility in any way for use of any of the Products for the above special purposes. If a Product is intended to be used for any such special purpose, please contact a ROHM sales representative before purchasing.

If you intend to export or ship overseas any Product or technology specified herein that may be controlled under the Foreign Exchange and the Foreign Trade Law, you will be required to obtain a license or permit under the Law.

ROHM Sales Offices

Contact us for further information about the products.

R0039A

San Diego +1-858-625-3630	United Kingdom +44-1-908-272400	Tianjin +86-22-23029181	Xiamen +86-592-238-5705
Atlanta +1-770-754-5972	Denmark +45-3694-4739	Shanghai +86-21-6279-2727	Zhuhai +86-756-3232-480
Boston +1-978-371-0382	Espoo +358-9725-54491	Hangzhou +86-571-87658072	Hong Kong +852-2-740-6262
Chicago +1-847-368-1006	Salo +358-2-7332234	Nanjing +86-25-8689-0015	Taipei +886-2-2500-6956
Dallas +1-972-473-3748	Oulu +358-8-5372930	Ningbo +86-574-87654201	Kaohsiung +886-7-237-0881
Denver +1-303-708-0908	Barcelona +34-9375-24320	Qingdao +86-532-8577-9312	Singapore +65-6332-2322
Detroit +1-248-348-9920	Hungary +36-1-4719338	Suzhou +86-512-6807-1300	Philippines +63-2-807-6872
Nashville +1-615-620-6700	Poland +48-22-5757213	Wuxi +86-510-82702693	Thailand +66-2-254-4890
Mexico +52-33-3123-2001	Russia +7-495-739-41-74	Guangzhou +86-20-3878-8100	Kuala Lumpur +60-3-7958-8355
Düsseldorf +49-2154-9210	Seoul +82-2-8182-700	Huizhou +86-752-205-1054	Penang +60-4-2286453
Munich +49-8999-216168	Masan +82-55-240-6234	Fuzhou +86-591-8801-8698	Kyoto +81-75-365-1218
Stuttgart +49-711-7272-370	Dalian +86-411-8230-8549	Dongguan +86-769-8393-3320	Yokohama +81-45-476-2290
France +33-1-5697-3060	Beijing +86-10-8525-2483	Shenzhen +86-755-8307-3008	

ROHM Co.,Ltd.

21 Sain Mizosaki-cho, Ukyo-ku,
Kyoto 615-8585 Japan

TEL : +81-75-311-2121 FAX : +81-75-315-0172

www.rohm.com

