

1-chip High-current System with High Withstand Voltage

STEP DOWN CONVERTER



Power Supply IC

BD9322EFJ, BD9323EFJ, BD9324EFJ
DESIGN INFORMATION
●Description

The BD9322EFJ, BD9323EFJ and BD9324EFJ are step-down regulators that integrate a low resistance high side N-channel MOSFET.

It achieves 2A / 3A / 4A continuous output current over a wide input supply range.

Current mode operation provides fast transient response and easy phase compensation.

●Features

- 1) Wide operating INPUT Range **4.75V~18V**
- 2) Selectable **2A / 3A / 4A** Output Current
- 3) Selectable **0.1Ω / 0.15Ω** Internal MOSFET Switch
- 4) Low ESR Output Ceramic Capacitors are Available
- 5) Low Standby Current during Shutdown Mode
- 6) **380kHz** Operating Frequency
- 7) Feedback voltage 0.9V $\pm 1.5\%$ Accuracy
- 8) Protection circuit: Undervoltage lockout protection circuit
Thermal shutdown circuit
Overcurrent protection circuit
- 9) HTSOP-J8 Package (with Exposed thermal PAD)

●Applications

Distributed Power System

Pre-Regulator for Linear Regulator

●Absolute maximum ratings (Ta = 25°C)

Parameter	Symbol	Rating	Unit
Supply Voltage	V _{IN}	20	V
Switch Voltage	V _{SW}	20	V
Power Dissipation for HTSOP-J8	P _d	3760*	mW
Operating Temperature Range	T _{opr}	-40~+85	°C
Storage Temperature Range	T _{stg}	-55~+150	°C
Junction Temperature	T _{jmax}	150	°C
BST Voltage	V _{BST}	V _{SW} +7	V
All other pins	V _{OTH}	7	V

* Derating in done 30.08 mW/°C for operating above Ta ≥ 25°C (Mount on 4-layer 70.0mm × 70.0mm × 1.6mm board)

● Operation Range(Ta= -40~85°C)

Parameter	Symbol	Min	Typ	Max	Unit
Supply Voltage	V _{IN}	4.75	12	18	V
Output current for BD9322EFJ	I _{SW2}	—	—	2**	A
Output current for BD9323EFJ	I _{SW3}	—	—	3**	A
Output current for BD9324EFJ	I _{SW4}	—	—	4**	A

** Pd, ASO should not be exceeded

● Electrical characteristics (unless otherwise specified VIN=12V Ta=25°C)

Parameter	Symbol	Limits			Unit	Conditions
		Min	Typ	Max		
Error amplifier block						
FB input bias current	I _{FB}	-	0.1	2	μA	
Feedback voltage	V _{FB}	0.886	0.900	0.914	V	Voltage follower
SW block – SW						
Hi-side FET On-resistance for BD9322EFJ	R _{ON2}	-	0.15	-	Ω	I _{SW} = -0.8A ***
Hi-side FET On-resistance for BD9323EFJ	R _{ON3}	-	0.10	-	Ω	I _{SW} = -0.8A ***
Hi-side FET On-resistance for BD9324EFJ	R _{ON4}	-	0.10	-	Ω	I _{SW} = -0.8A ***
Lo-side FET On-resistance	R _{ONL}	-	10	-	Ω	I _{SW} = 0.1A
Leak current N-channel	I _{LEAKN}	-	0	10	μA	V _{IN} = 18V, V _{SW} = 0V
Switch Current Limit for BD9322EFJ	I _{LIMIT2}	2.5	-	-	A	***
Switch Current Limit for BD9323EFJ	I _{LIMIT3}	3.5	-	-	A	***
Switch Current Limit for BD9324EFJ	I _{LIMIT4}	4.5	-	-	A	***
Maximum duty cycle	M _{DUTY}	-	90	-	%	V _{FB} = 0V
General						
Enable Pull-up current	I _{EN}	12	23	34	μA	V _{EN} = 0V
Enable Threshold voltage	V _{EN}	0.6	0.63	0.66	V	
Under Voltage Lockout threshold	V _{UVLO}	4.05	4.40	4.75	V	V _{IN} rising
Under Voltage Lockout Hysteresis	V _{HYS}	-	0.1	-	V	
Soft Start Current	I _{SS}	23	41	62	μA	V _{SS} = 0.1 V
Soft Start Time	T _{SS}	-	1.6	-	ms	C _{SS} = 0.1 μF
Operating Frequency	F _{OSC}	300	380	460	kHz	
Circuit Current	I _{CC}	-	2.1	4.3	mA	V _{FB} = 1.5V, V _{EN} = OPEN
Quiescent Current	I _{QUI}	-	100	190	μA	V _{EN} = 0V

*** See the series line-up table below.

● Series Line-up Table

LINE-UP	BD9322EFJ	BD9323EFJ	BD9324EFJ
FET ON-RESISTANCE	0.15 Ω	0.10 Ω	0.10 Ω
OUTPUT CURRENT	2.0 A	3.0A	4.0 A

● Block Diagram

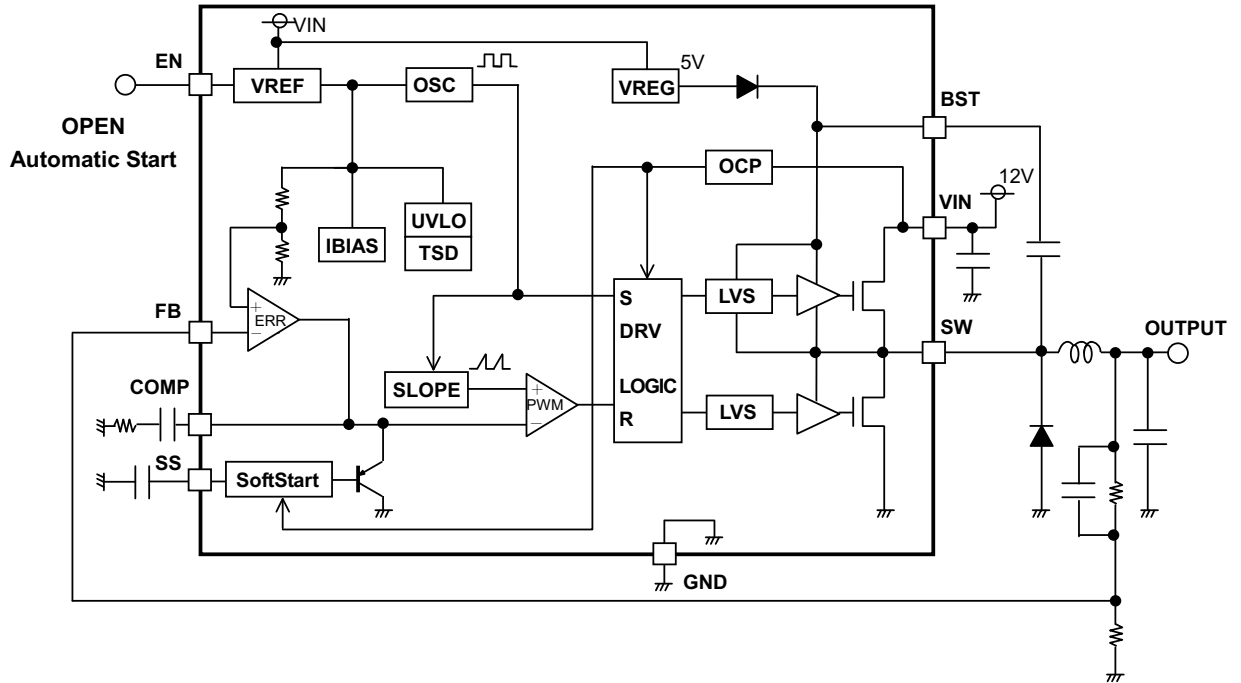

● Typical Application Circuit

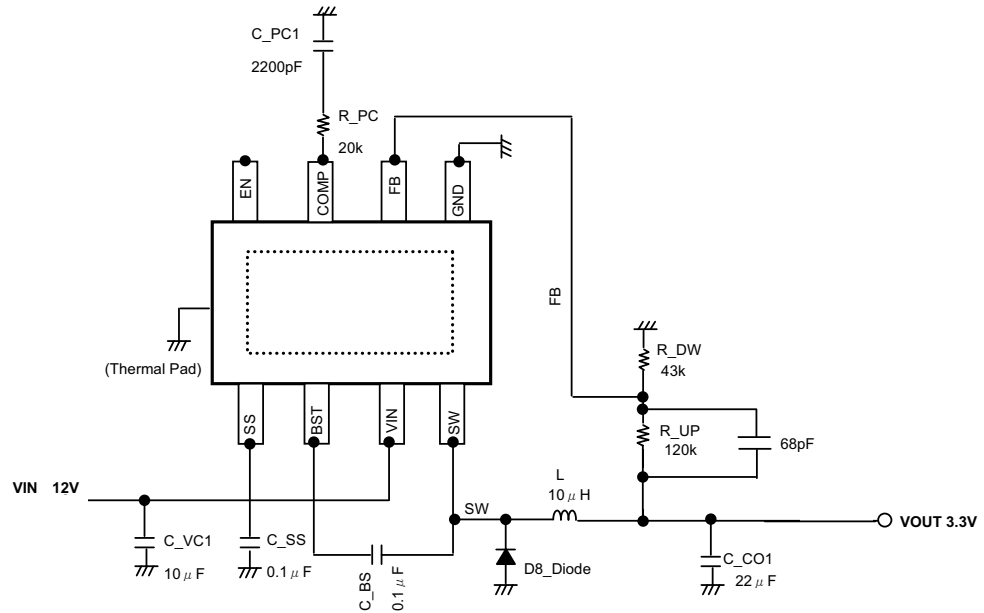

- Block Operation

- VREG

A block to generate constant-voltage for DC/DC boosting.

- VREF

A block that generates internal reference voltage of 2.9 V (Typ.).

- TSD/UVLO

TSD (Thermal shutdown)/UVLO (Under Voltage Lockout) protection block. The TSD circuit shuts down IC at 175°C (Typ.)
The UVLO circuit shuts down the IC when the Vcc is Low Voltage.

- Error amp block (ERR)

This is the circuit to compare the reference voltage and the feedback voltage of output voltage. The COMP pin voltage resulting from this comparison determines the switching duty. At the time of startup, since the soft start is operated by the SS pin voltage, the COMP pin voltage is limited to the SS pin voltage.

- Oscillator block (OSC)

This block generates the oscillating frequency.

- SLOPE block

This block generates the triangular waveform from the clock created by OSC. Generated triangular waveform is sent to the PWM comparator.

- PWM block

The COMP pin voltage output by the error amp is compared to the SLOPE block's triangular waveform to determine the switching duty. Since the switching duty is limited by the maximum duty ratio which is determined internally, it does not become 100%.

- DRV block

A DC/DC driver block. A signal from the PWM is input to drive the power FETs.

- Soft start circuit

Since the output voltage rises gradually while restricting the current at the time of startup, it is possible to prevent the output voltage overshoot or the rush current.

● Physical Dimension (TBD)

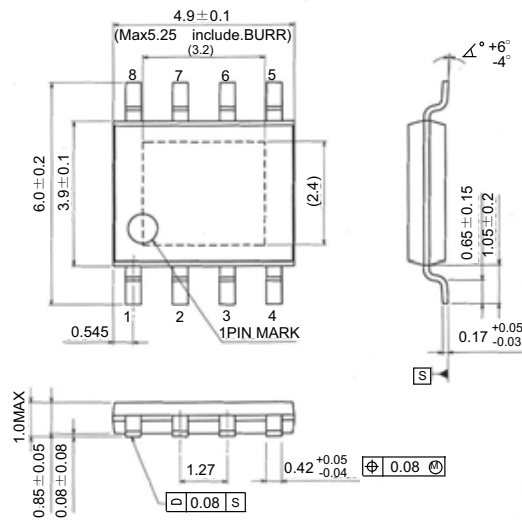

Fig HTSOP-J8 Package (TBD)
(Unit:mm)

● Pin Assignment and Pin Function

Pin No.	Pin name	Function
1	SS	Soft Start Control Input
2	BST	High-Side Gate Drive Boost Input
3	VIN	Power Input
4	SW	Power Switching Output
5	GND	Ground
6	FB	Feed Back Input
7	COMP	Compensation Node
8	EN	Enable Input

● Typical Performance Characteristics (Unless otherwise specified, VIN= 12V Ta = 25°C)

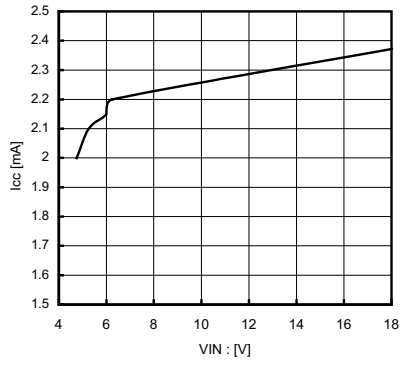

Fig. Circuit Current
(No switching)

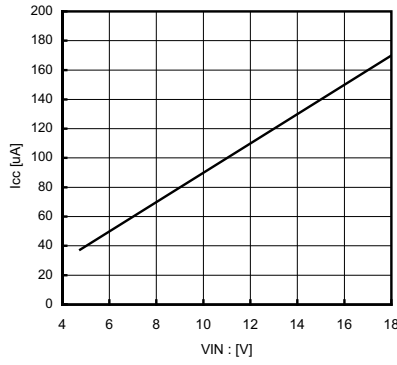

Fig. Quiescent Current
(IC not active)

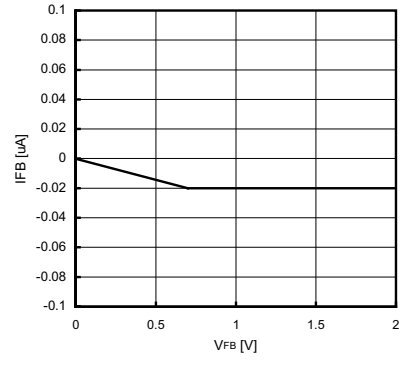

Fig. Input Bias Current

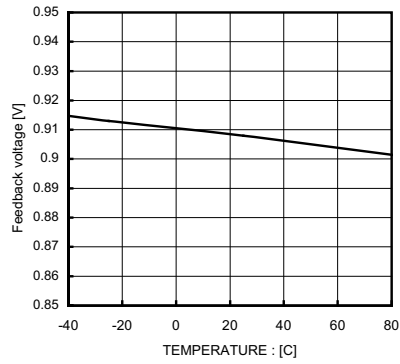

Fig. Feedback voltage

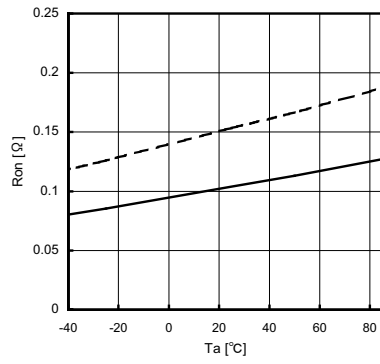

Fig. Hi-Side On-resistance

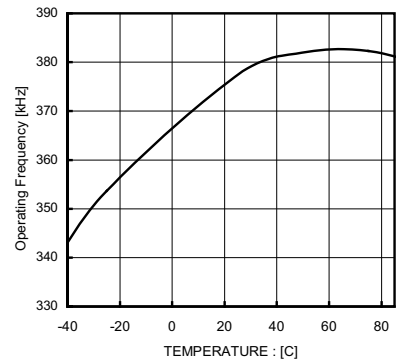

Fig. Operating Frequency

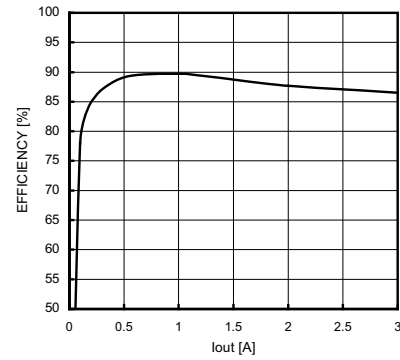

Fig. STEP Down Efficiency
(VIN= 12V V_{out}= 3.3V L= 22μH)

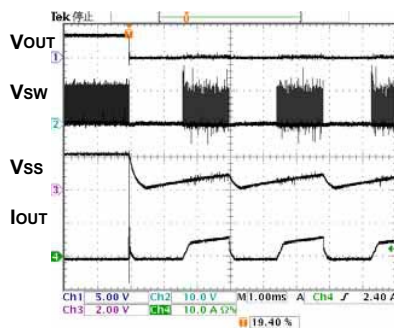

Fig. OverCurrent Protection
(V_{out} is shorted to GND)

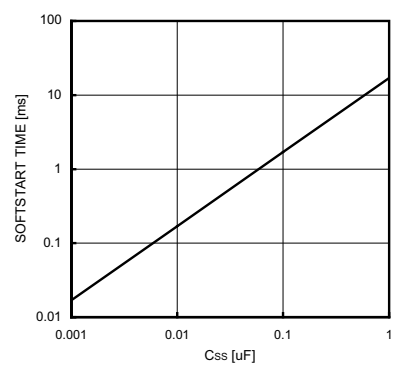

Fig. Soft Start Time

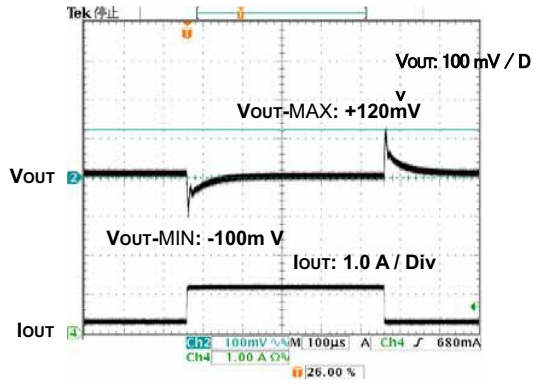

Fig. Transient Response
 (VIN= 12V Vout= 3.3V L= 10uH Cout=22uF Iout= 0.2-1.0A)

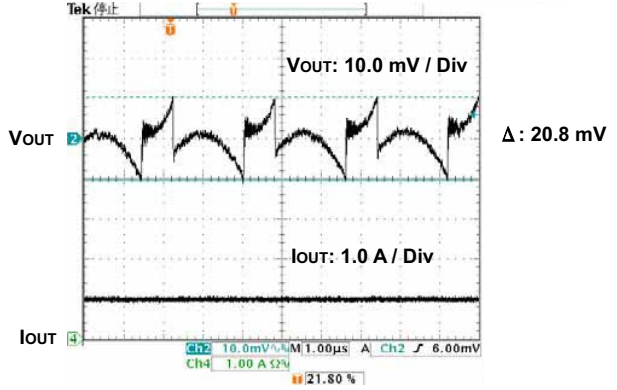

Fig. Output Ripple Voltage
 (VIN= 12V Vout= 3.3V L= 10uH Cout=22uF Iout= 1.0A)

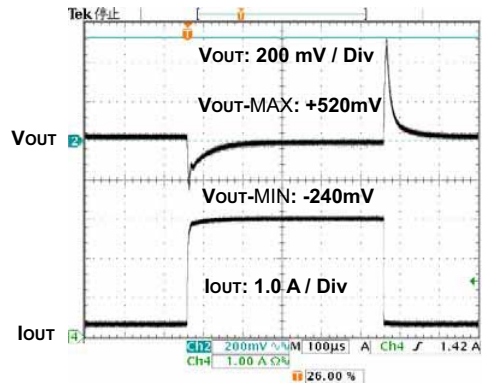

Fig. Transient Response
 (VIN= 12V Vout= 3.3V L= 10uH Cout=22uF Iout= 0.2-3.0A)

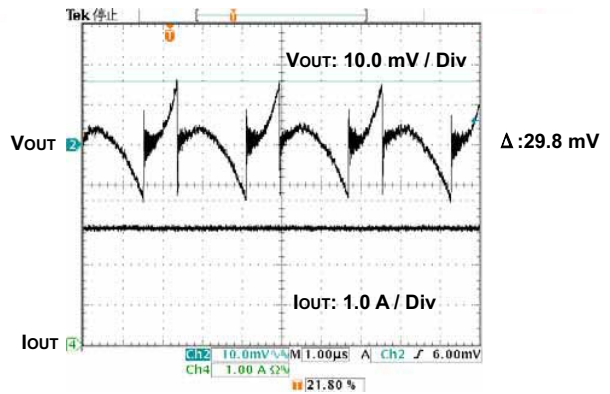

Fig. Output Ripple Voltage
 (VIN= 12V Vout= 3.3V)

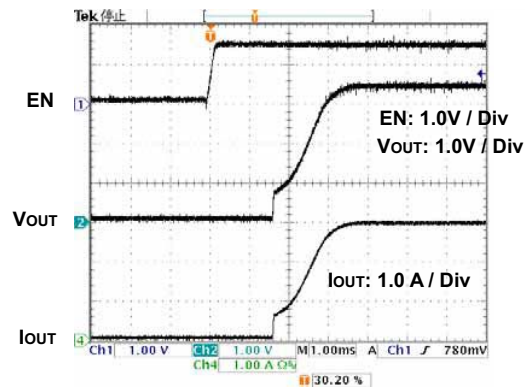

Fig. Start Up waveform
 (VIN= 12V Vout= 3.3V L= 10uH C_{ss}= 0.1uF)

● Selecting Application Components

(1) Output LC constant (Buck Converter)

The inductance L to use for output is decided by the rated current ILR and input current maximum value IOMAX of the inductance.

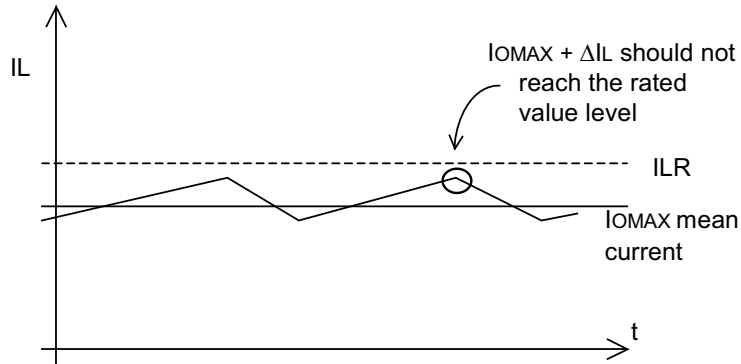

Fig.

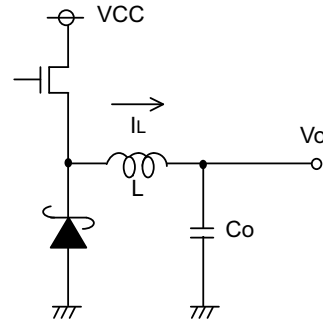

Fig.

Adjust so that $I_{OMAX} + \Delta I_L$ does not reach the rated current value I_{LR} . At this time, ΔI_L can be obtained by the following equation.

$$\Delta I_L = \frac{1}{L} \times (V_{CC} - V_o) \times \frac{V_o}{V_{CC}} \times \frac{1}{f} \text{ [A]}$$

Set with sufficient margin because the inductance L value may have the dispersion of $\pm 30\%$.

For the capacitor C to use for the output, select the capacitor which has the larger value in the ripple voltage V_{PP} permissible value and the drop voltage permissible value at the time of sudden load change.

Output ripple voltage is decided by the following equation.

$$\Delta V_{PP} = \Delta I_L \times R_{ESR} + \frac{\Delta I_L}{2C_o} \times \frac{V_o}{V_{CC}} \times \frac{1}{f} \text{ [V]}$$

Perform setting so that the voltage is within the permissible ripple voltage range.

For the drop voltage V_{DR} during sudden load change, please perform the rough calculation by the following equation.

$$V_{DR} = \frac{\Delta I}{C_o} \times 10 \text{ us} \text{ [V]}$$

However, $10\mu\text{s}$ is the rough calculation value of the DC/DC response speed.

Make C_o settings so that these two values will be within the limit values.

(2) Phase compensation

Phase Setting Method

The following conditions are required in order to ensure the stability of the negative feedback circuit.

- Phase lag should be 150° or lower during gain 1 (0 dB) (phase margin of 30° or higher).

Because DC/DC converter applications are sampled using the switching frequency, the overall GBW should be set to 1/10 the switching frequency or lower. The target application characteristics can be summarized as follows:

- Phase lag should be 150° or lower during gain 1 (0 dB) (phase margin of 30° or higher).
- The GBW at that time (i.e., the frequency of a 0-dB gain) is 1/10 of the switching frequency or below.

In other words, because the response is determined by the GBW limitation, it is necessary to use higher switching frequencies to raise response.

One way to maintain stability through phase compensation involves canceling the secondary phase lag (-180°) caused by LC resonance with a secondary phase advance (by inserting a phase advances).

The GBW (i.e., the frequency with the gain set to 1) is determined by the phase compensation capacitance connected to the error amp. Increase the capacitance if a GBW reduction is required.

(a) Standard integrator (low-pass filter)

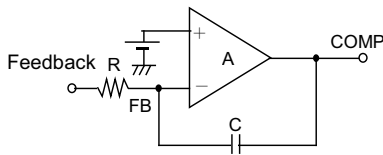

Fig.

(b) Open loop characteristics of integrator

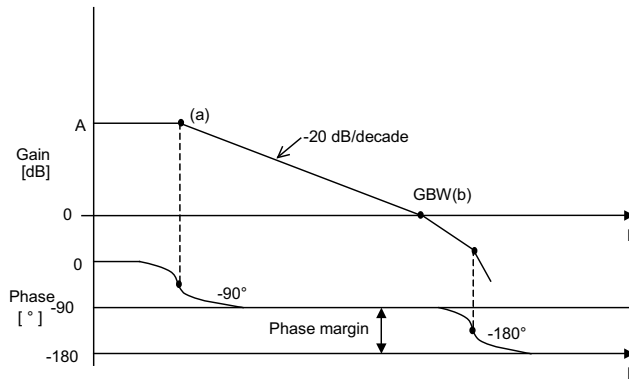

Fig.

Point (a) $f_a = \frac{1}{2\pi R C A}$ [Hz]

Point (b) $f_b = \text{GBW} = \frac{1}{2\pi R C}$ [Hz]

The error amp performs phase compensation of types (a) and (b), making it act as a low-pass filter.

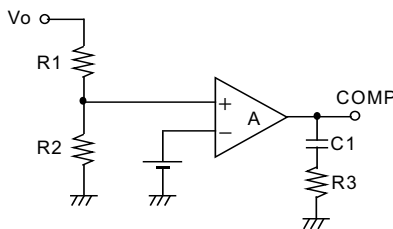

Fig.

LC resonant frequency $f_p = \frac{1}{2\pi \cdot LC}$ [Hz]

Phase advance $f_z = \frac{1}{2\pi C_1 R_3}$ [Hz]

Set a phase advancing frequency close to the LC resonant frequency for the purpose of canceling the LC resonance.

● Selecting the Feedforward Capacitor

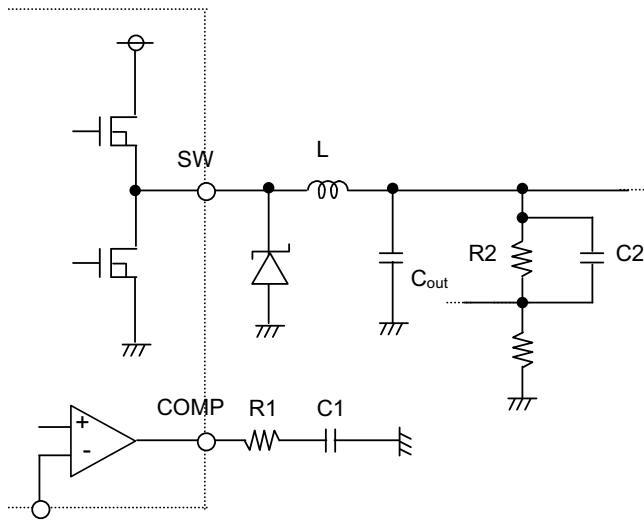

For a stable converter loop and the best transient response, the bypass capacitors for phase compensation are needed.

The regulator loop can be compensated by adjusting the external components connected to COMP pin. C1 is decided by the following formula.

$$C1 = \frac{1}{2\pi \cdot F_{z1} \cdot R1} \quad [F]$$

$$F_{z1} = 1/3 \cdot F_{LC} \quad [Hz]$$

$$F_{LC} = \frac{1}{2\pi\sqrt{L} \cdot C_{out}} \quad [Hz]$$

Across the upper resistor R2, a bypass capacitor is needed to have a better transient response. C2 will set a zero in the loop together with R2.

$$C2 = \frac{1}{2\pi \cdot F_{z2} \cdot R2} \quad [F]$$

$$F_{z2} = 3 \cdot F_{LC} \quad [Hz]$$

$$F_{LC} = \frac{1}{2\pi\sqrt{L} \cdot C_{out}} \quad [Hz]$$

※Depending on the PCB patterns or conditions, the further adjustment beyond the calculated value above might be needed.

● Soft Start Function

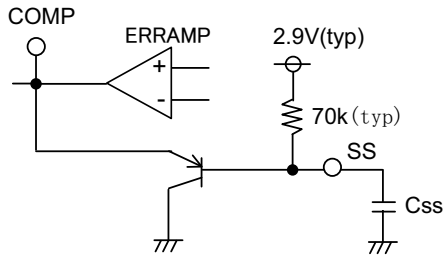

The buck converter has an adjustable SoftStart function to prevent high inrush current during start up.

The soft-start time is set by the external capacitor connected to SS pin.

The soft start time is given by;

$$T_{ss} [ms] = 16.2 \cdot C_{ss} [\mu F]$$

Please confirm the overshoot of the output voltage and inrush current when deciding the SS capacitor value.

● EN Function

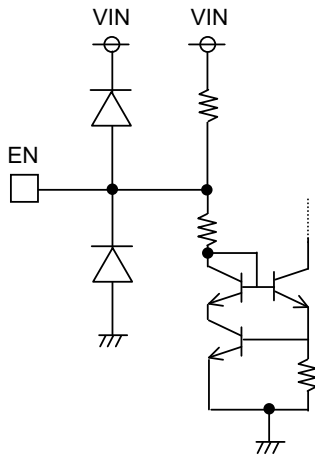

The EN terminal controls IC's shut down.

Leaving EN terminal open, makes IC start up automatically.

To shut down the IC, the external component has to pull the current from EN terminal and make the EN voltage low.

The EN threshold voltage is 0.63V (typ.).

The equivalent internal circuit.

ex)

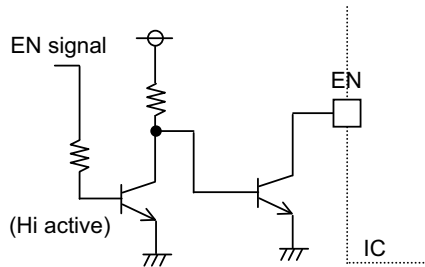

The example of EN driving circuit.

(3) Design of Feedback Resistance constant

Set the feedback resistance as shown below.

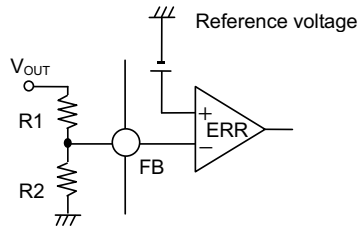

$$V_{OUT} = \frac{R1 + R2}{R2} \times \text{Reference Voltage} \quad [V]$$

Fig.

● I/O Equivalent Circuit Diagram Fig.

<p>1.SS</p>	<p>2.BST</p>	<p>4.SW</p>
<p>6.FB</p>	<p>7.COMP</p>	<p>8.EN</p>

● Operation Notes

1) Absolute maximum ratings

Use of the IC in excess of absolute maximum ratings such as the applied voltage or operating temperature range may result in IC damage. Assumptions should not be made regarding the state of the IC (short mode or open mode) when such damage is suffered. A physical safety measure such as a fuse should be implemented when use of the IC in a special mode where the absolute maximum ratings may be exceeded is anticipated.

2) GND potential

Ensure a minimum GND pin potential in all operating conditions.

3) Setting of heat

Use a thermal design that allows for a sufficient margin in light of the power dissipation (Pd) in actual operating conditions.

4) Pin short and mistake fitting

Use caution when orienting and positioning the IC for mounting on printed circuit boards. Improper mounting may result in damage to the IC. Shorts between output pins or between output pins and the power supply and GND pins caused by the presence of a foreign object may result in damage to the IC.

5) Actions in strong magnetic field

Use caution when using the IC in the presence of a strong magnetic field as doing so may cause the IC to malfunction.

6) Testing on application boards

When testing the IC on an application board, connecting a capacitor to a pin with low impedance subjects the IC to stress. Always discharge capacitors after each process or step. Ground the IC during assembly steps as an antistatic measure, and use similar caution when transporting or storing the IC. Always turn the IC's power supply off before connecting it to or removing it from a jig or fixture during the inspection process.

7) Ground wiring patterns

When using both small signal and large current GND patterns, it is recommended to isolate the two ground patterns, placing a single ground point at the application's reference point so that the pattern wiring resistance and voltage variations caused by large currents do not cause variations in the small signal ground voltage. Be careful not to change the GND wiring patterns of any external components.

8) Regarding input pin of the IC

This monolithic IC contains P+ isolation and P substrate layers between adjacent elements in order to keep them isolated. P/N junctions are formed at the intersection of these P layers with the N layers of other elements to create a variety of parasitic elements. For example, when the resistors and transistors are connected to the pins as shown in Fig. , a parasitic diode or a transistor operates by inverting the pin voltage and GND voltage. The formation of parasitic elements as a result of the relationships of the potentials of different pins is an inevitable result of the IC's architecture. The operation of parasitic elements can cause interference with circuit operation as well as IC malfunction and damage. For these reasons, it is necessary to use caution so that the IC is not used in a way that will trigger the operation of parasitic elements such as by the application of voltages lower than the GND (P substrate) voltage to input and output pins.

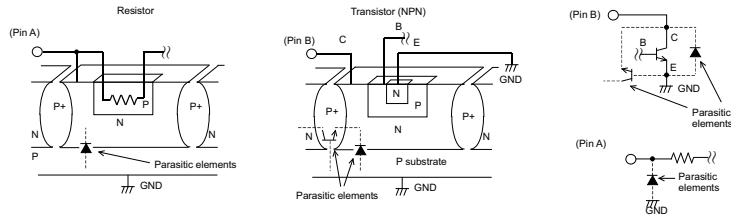

Fig. Example of a Simple Monolithic IC Architecture

9) Overcurrent protection circuits

An overcurrent protection circuit designed according to the output current is incorporated for the prevention of IC damage that may result in the event of load shorting. This protection circuit is effective in preventing damage due to sudden and unexpected accidents. However, the IC should not be used in applications characterized by the continuous operation or transitioning of the protection circuits. At the time of thermal designing, keep in mind that the current capacity has negative characteristics to temperatures.

10) Thermal shutdown circuit (TSD)

This IC incorporates a built-in TSD circuit for the protection from thermal destruction. The IC should be used within the specified power dissipation range. However, in the event that the IC continues to be operated in excess of its power dissipation limits, the attendant rise in the chip's junction temperature Tj will trigger the TSD circuit to turn off all output power elements. Operation of the TSD circuit presumes that the IC's absolute maximum ratings have been exceeded. Application designs should never make use of the TSD circuit.

11) Testing on application boards

At the time of inspection of the installation boards, when the capacitor is connected to the pin with low impedance, be sure to discharge electricity per process because it may load stresses to the IC. Always turn the IC's power supply off before connecting it to or removing it from a jig or fixture during the inspection process. Ground the IC during assembly steps as an antistatic measure, and use similar caution when transporting or storing the IC.

● Power Dissipation

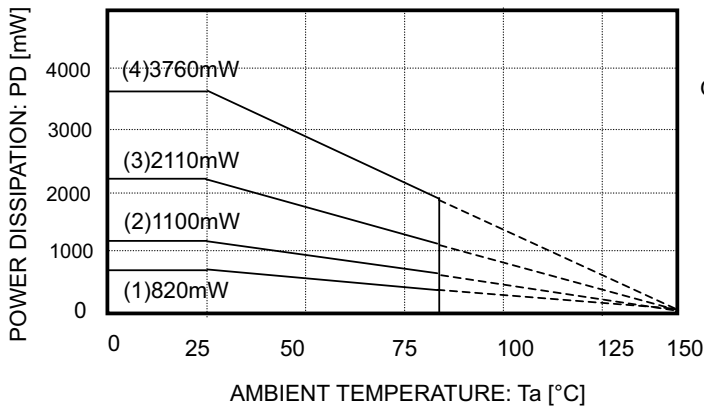

On 70 × 70 × 1.6 mm glass epoxy PCB

- (1) 1-layer board (Backside copper foil area 0 mm × 0 mm)
- (2) 2-layer board (Backside copper foil area 15 mm × 15 mm)
- (3) 2-layer board (Backside copper foil area 70 mm × 70 mm)
- (4) 4-layer board (Backside copper foil area 70 mm × 70 mm)

- The contents described herein are correct as of October, 2005
- The contents described herein are subject to change without notice. For updates of the latest information, please contact and confirm with ROHM CO.,LTD.
- Any part of this application note must not be duplicated or copied without our permission.
- Application circuit diagrams and circuit constants contained herein are shown as examples of standard use and operation. Please pay careful attention to the peripheral conditions when designing circuits and deciding upon circuit constants in the set.
- Any data, including, but not limited to application circuit diagrams and information, described herein are intended only as illustrations of such devices and not as the specifications for such devices. ROHM CO.,LTD. disclaims any warranty that any use of such devices shall be free from infringement of any third party's intellectual property rights or other proprietary rights, and further, assumes no liability of whatsoever nature in the event of any such infringement, or arising from or connected with or related to the use of such devices.
- Upon the sale of any such devices, other than for buyer's right to use such devices itself, resell or otherwise dispose of the same, implied right or license to practice or commercially exploit any intellectual property rights or other proprietary rights owned or controlled by ROHM CO., LTD. is granted to any such buyer.
- The products described herein utilize silicon as the main material.
- The products described herein are not designed to be X ray proof.

The products listed in this catalog are designed to be used with ordinary electronic equipment or devices (such as audio visual equipment, office-automation equipment, communications devices, electrical appliances and electronic toys). Should you intend to use these products with equipment or devices which require an extremely high level of reliability and the malfunction of which would directly endanger human life (such as medical instruments, transportation equipment, aerospace machinery, nuclear-reactor controllers, fuel controllers and other safety devices), please be sure to consult with our sales representative in advance.

Excellence in Electronics



ROHM CO., LTD.

21, Saiin Mizosaki-cho, Ukyo-ku, Kyoto
615-8585, Japan
TEL: (075)311-2121 FAX: (075)315-0172
URL: <http://www.rohm.com>

Published by

Application Engineering Group

Contact us for further information about the products.

Atlanta U.S.A. / ROHM ELECTRONICS ATLANTA SALES OFFICE
(DIVISION OF ROHM ELE.U.S.A.,LLC.)
TEL:+1(770)754-5972 FAX:+1(770)754-0691

Dallas U.S.A. / ROHM ELECTRONICS DALLAS SALES OFFICE
(DIVISION OF ROHM ELE.U.S.A.,LLC.)
TEL:+1(972)312-2818 FAX:+1(972)312-0330

San Diego U.S.A. / ROHM ELECTRONICS SAN DIEGO SALES OFFICE
(DIVISION OF ROHM ELE.U.S.A.,LLC.)
TEL:+1(658)625-3630 FAX:+1(658)625-3670

Germany / ROHM ELECTRONICS GMBH (GERMANY)
TEL:+49(2154)9210 FAX:+49(2154)921400

United Kingdom / ROHM ELECTRONICS GMBH (UK)
TEL:+44(0)1908-306700 FAX:+44(0)1908-235788

France / ROHM ELECTRONICS GMBH (FRANCE)
TEL:+33(0)1 56 87 30 60 FAX:+33(0)1 56 87 30 80

Hong Kong China / ROHM ELECTRONICS (H.K.) CO., LTD.
TEL:+852(2)7406262 FAX:+852(2)375-8971

Shanghai China / ROHM ELECTRONICS (SHANGHAI) CO., LTD.
TEL:+86(21)6275-2727 FAX:+86(21)6247-2066

Dalian China / ROHM ELECTRONICS TRADING (DALIAN) CO., LTD.
TEL:+86(411)8230-8549 FAX:+86(411)8230-8537

Beijing China / BEIJING REPRESENTATIVE OFFICE
TEL:+86(10)8525-2483 FAX:+86(10)8525-2489

Taiwan / ROHM ELECTRONICS TAIWAN CO., LTD.
TEL:+886(2)2500-4956 FAX:+886(2)2503-2869

Korea / ROHM ELECTRONICS KOREA CORPORATION
TEL:+82(2)8182-700 FAX:+82(2)8182-715

Singapore / ROHM ELECTRONICS ASIA PTE.LTD. (RES./REI)
TEL:+65-6332-2322 FAX:+65-6332-5662

Malaysia / ROHM ELECTRONICS (MALAYSIA) SDN. BHD.
TEL:+60(3)7588-6355 FAX:+60(3)7588-6377

Philippines / ROHM ELECTRONICS (PHILIPPINES) SALES CORPORATION
TEL:+63(2)807-6872 FAX:+63(2)809-1422

Thailand / ROHM ELECTRONICS (THAILAND) CO., LTD.
TEL:+66(2)254-4990 FAX:+66(2)256-6334