

IC Card Interface ICs

Low noise IC Card Interface with LDO regulator

BD8919F



- Overview

This is an interface IC for a 5V smart card.

It works as a bidirectional signal buffer between a smart card and a controller. Also, it supplies 5V power to a smart card.

With an electrostatic breakdown voltage of more than HBM; $\pm 6000\text{V}$, it protects the card contact pins.

- Features

- 1) 1 half duplex bidirectional buffers
- 2) Protection against short-circuit for all the card contact pins
- 3) 5V power source for the card (VCC)
- 4) Over-current protection for card power source
- 5) Built-in thermal shutdown circuit
- 6) Built-in supply voltage detector
- 7) Automatic activation/deactivation sequence function for card contact pin
 - Activation sequence: driven by a signal from controller (CMDVCCB \downarrow)
 - Deactivation sequence: driven by a signal from controller (CMDVCCB \uparrow) and fault detection (card removal, short circuit of card power, IC overheat detection, VDD or VDDP drop)
- 8) Card contact pin ESD voltage $\geq \pm 6000\text{V}$
- 9) 16MHz integrated crystal oscillator
- 10) Programmable for card clock division of output signal by 1/2 and 1/4.
- 11) RST output control by RSTIN input signal (positive output)
- 12) One multiplexed card status output by OFFB signal

- Application

Interface for CLASS A smart cards

Interface for B-CAS cards

• Absolute maximum ratings (Ta=25°C)

Parameter	Symbol	Rating	Unit	Note
VDD Input Voltage	V _{DD}	-0.3 - 6.5	V	
VDDP Input Voltage	V _{DDP}	-0.3 - 6.5	V	
I/O Pin Voltage	V _{IN} V _{OUT}	-0.3 - +6.5	V	Pin: XTAL1, XTAL2, CLKSEL, RSTIN, IO_U CMDVCCB, OFFB
Card Contact Pin Voltage	V _{REG}	-0.3 - +6.5	V	Pin: PRES, CLK, RST, IO_C
Junction Temperature	T _{jmax}	+150	°C	
Storage Temperature	T _{stg}	-55 - +150	°C	
Power Dissipation	P _{tot}	375	mW	Ta=-40 - +85°C * Refer to the following package power dissipation

• This product is not designed to be radiation tolerant. • Absolute maximum ratings are not meant for guarantee of operation.

• Operating Conditions (Ta=25°C)

Parameter	Symbol	MIN	TYP	MAX	Unit	Note
VDD Input Voltage	V _{DD}	2.7	-	5.5	V	
VDDP Input Voltage	V _{DDP}	4.75	5.0	5.5	V	VCC ≥ 4.55V; Ivreg ≤ 60mA
Operating Temperature	T _{opr}	-40	-	+85	°C	

• Package Power Dissipation

The power dissipation of a simple package in case of a boardless will be as follows.

Use of this device beyond the following the power dissipation may cause permanent damage.

Pd=375mW; however, reduce 3mW per 1°C when used at Ta ≥ 25°C.

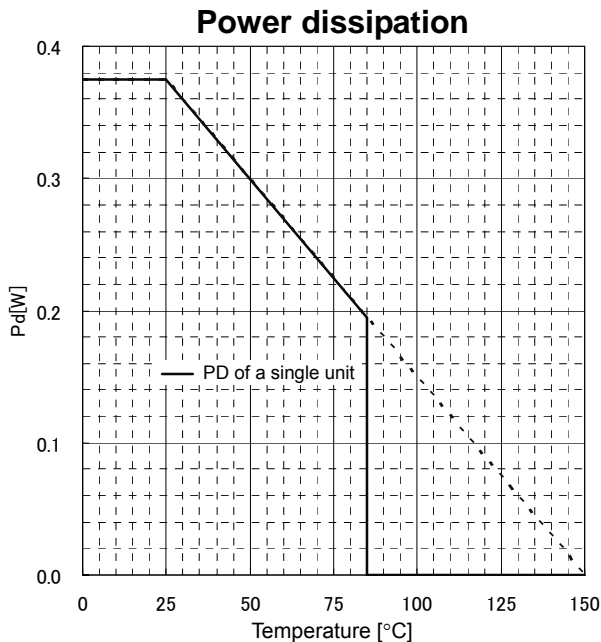

Fig. 1 BD8919F Power Dissipation

●Pin Description

Pin No.	Pin Name	I/O	Signal Level	Pin Function
1	XTAL1	I	VDD	Crystal connection or input for external clock
2	XTAL2	O	VDD	Crystal connection (leave open pin when external clock source is used)
3	VDD	S	VDD	3.3 V power source pin for host interface. Connect 0.1 μ F capacitor between the VDD and GND pins.
4	CLKSEL	I	VDD	Input for clock frequency division setting. H: 1/2 division; L: 1/4 division. Pulled down to GND with a 50k Ω resistor.
5	RSTIN	I	VDD	Card reset signal input. Pulled down to GND with a 50k Ω resistor.
6	IO_U	I/O	VDD	Host data I/O line; Pulled up to VDD with an 11k Ω resistor
7	CGND	S	GND	GND
8	IO_C	I/O	VCC	I/O data line on the card side. Pulled up to VCC with an 11k Ω resistor.
9	RST	O	VCC	Card reset output
10	CLK	O	VCC	Card clock output
11	VCC	O	VCC	Card supply voltage. Connect 1 μ F capacitor between VCC and the CGND pins.
12	VDDP	S	VDDP	5V power source pin for card power feed. Connect 10 μ F capacitor between the VDDP and CGND pins.
13	PRES	I	VDD	Card presence contact input (“H” active). Pulled up to VDD with a 50k Ω resistor. Connected to a switch where GND level is inputted when no card is inserted and OPEN is inputted when a card is inserted. When “H” level is detected, a card is assumed to be inserted and waits for the CMDVCCB input for the confirmation, after the debounce time of typ. 8ms.
14	OFFB	O	VDD	Alarm output pin (“L” active). NMOS open drain output. Pulled up to VDD with a 20k Ω resistor.
15	CMDVCCB	I	VDD	Activation sequence command input; The activation sequence starts by signal input (H→L) from the host
16	GND	S	GND	GND

* Capacitors to be connected to VDD, VDDP and VCC should be placed immediately next to the pins (ESR<100m Ω).

●Pin Function Diagram

Pin No.	Pin Name	Pin function Diagram
1	XTAL1	
2	XTAL2	
3	VDD	
4	CLKSEL	
5	RSTIN	
6	IO_U	
7	CGND	-----

Pin No.	Pin Name	Pin function Diagram
8	IO_C	
9	RST	
10	CLK	
11	VCC	

Pin No.	Pin Name	Pin function Diagram
12	VDDP	<p>The diagram shows pin 12 connected to a pull-up resistor. A diode is connected between the pin and ground, with the anode at the pin and the cathode to ground.</p>
13	PRES	<p>The diagram shows pin 13 connected to a pull-up resistor labeled $5k\Omega$ and a diode to ground. The pin is also connected to the input of a CMOS buffer circuit, which has its output connected to the pin. The buffer's supply rails are connected to VDD and GND.</p>

Pin No.	Pin Name	Pin function Diagram
14	OFFB	<p>The diagram shows pin 14 connected to a pull-up resistor labeled $20k\Omega$ and a diode to ground. The pin is also connected to the input of a CMOS buffer circuit, which has its output connected to the pin. The buffer's supply rails are connected to VDD and GND.</p>
15	CMDVCCB	<p>The diagram shows pin 15 connected to a pull-up resistor labeled $50k\Omega$ and a diode to ground. The pin is also connected to the input of a CMOS buffer circuit, which has its output connected to the pin. The buffer's supply rails are connected to VDD and GND.</p>
16	GND	-----

●Dimension

Package Name: SOP16

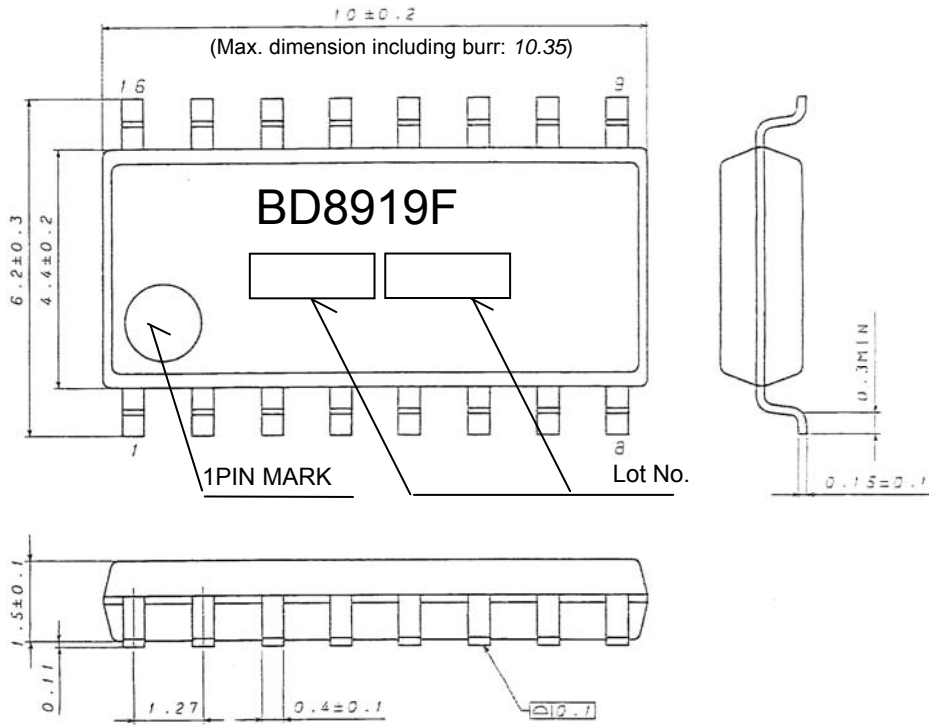

(UNIT : mm)

Fig. 3 SOP16 Package Dimension

● Function

1) Power supply

Power supply pins are VDD and VDDP. Set VDD at the same voltage as the signal from the system controller side. VDDP and CGND are for the 5V power source and GND, respectively, on the card side.

2) Input voltage detector

The IC remains in sleep mode until the power on reset is released 16ms after the VDD supply voltage is increased over V_{thd} and the VDDP supply voltage is increased over V_{thp} , making the CMDVCCB signal turn from H to L.

$$V_{thd}=1.7V(\text{typ}) \quad V_{thp}=2.25V(\text{typ})$$

3) Operation sequence

3-1) Wait mode

The IC remains in wait mode until the power on reset is released after the VDD supply voltage is increased over V_{thd} and the VDDP supply voltage is increased over V_{thp} , making the CMDVCCB signal turn from H to L.

In this mode, the VDD and VDDP supply voltage detector (VDET), thermal shutdown circuit (TSD), reference circuit (VREF) and crystal oscillation circuit (XT OSC) are activated.

IO_U is pulled up to VDD with an 11kΩ resistor and all the card contact pins are at Lo level.

3-2) Card presence

Card presence is detected by PRES pin. When the PRES pin is active, a card is assumed to be present.

Table 1

PRES	“High” active
------	---------------

When a card is present in sleep mode, the card insertion identification pin, PRES (“H” active) becomes active and OFFB becomes “H” after approx. 8ms (debounce time).

If a card is present before the VDD and VDDP power sources are applied and the internal reset is released, it is internally reset and OFFB becomes “H” after the debounce time.

The PRES pin is pulled up to VDD with a 50kΩ resistor.

3-3) Activation sequence

When OFFB is in the “High” state and the CMDVCCB signal from the controller turns from H to L, the activation sequence starts to activate each functional block in the following order:

The RST outputs signals based on the RSTIN input, being reset approximately 472 μ sec after the CMDVCCB signal turns from H to L. The RSTIN input becomes effective approximately 48 μ s after I/O TRANS turns ON. If RSTIN becomes Lo after RSTIN becomes effective and the RST output is released, the CLK signal is output. If RSTIN is High when the RST output is released, the CLK signal is output as soon as the RST output is released. (Refer to Fig. 4-1, 4-2 and 4-3)

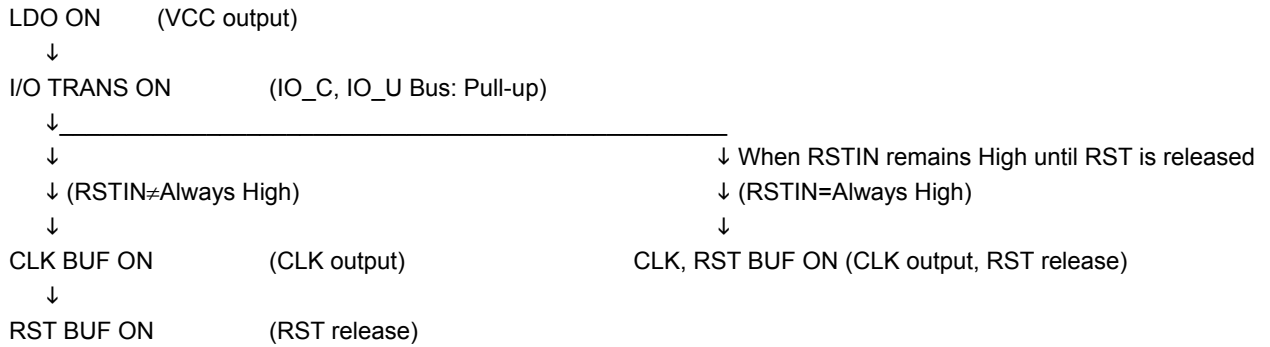

[Activation sequence under different RSTIN input timings]

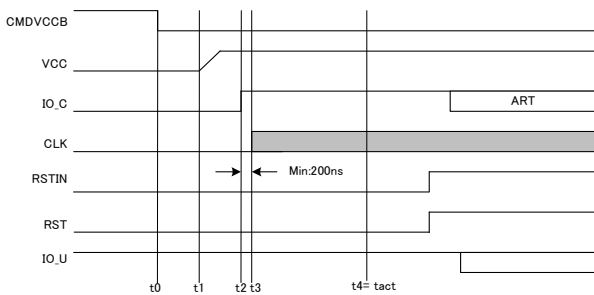

Fig. 4-1 Activation sequence 1

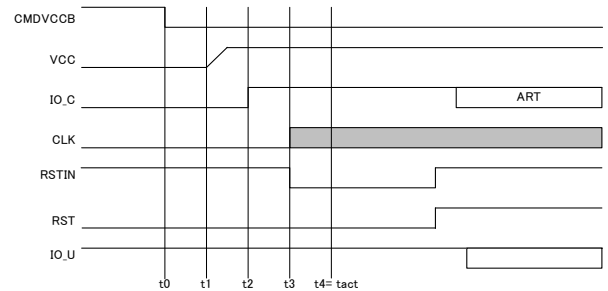

Fig. 4-2 Activation sequence 2

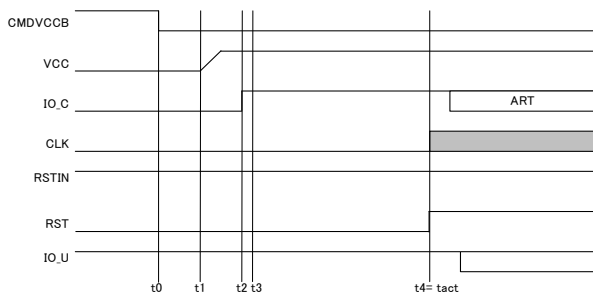
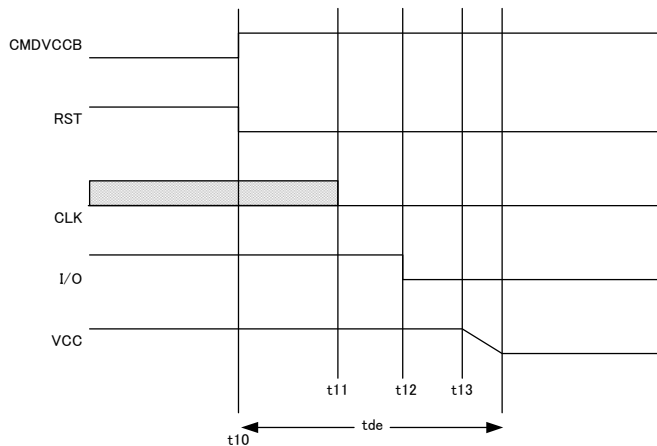
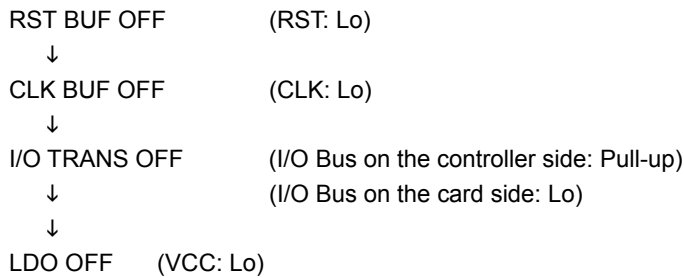

Fig. 4-3 Activation sequence 3
(RSTIN input sequence not specified by ISO7816)

- t1: LDO startup time = typ. 24 μ s
- t2: I/O ON time = typ. 424 μ s
- t3: CLK output release time (t3-t2) = Min. 200ns
- t4: RST release time = typ. 472 μ s, max. 481 μ s
(Activation time)

3-4) Deactivation sequence

When the CMDVCCB input turns from L to H or the alarm signal (described later) is detected, the following deactivation sequence is initiated in the following order, transitioning to the wait mode.



t11: CLK OFF time = typ. 10 μ s
t12: I/O OFF time = typ. 20 μ s
t13: Starting time of VCC fall = typ. 30 μ s
tde: Operational sequence completion time =Max. 200 μ s

Fig. 5 Deactivation sequence

4) LDO

LDO supplies power to the IC card through VCC pin.

This regulator has a built-in over-current limiter circuit. It generates an internal alarm with a load current of approximately 140mA or more and enters into the deactivation sequence. Also, the output voltage is regarded as abnormal if it drops to less than 1.6V and the output current is shut off; an internal alarm signal is generated and the deactivation sequence is initiated.

Connect a capacitor of 1 μ F or 2.2 μ F between VCC and CGND as close as possible to the VCC pin, in order to reduce the output voltage variation as much as possible. Also, ensure that ESR is kept at less than 100m Ω .

LDO output is also a power source for CLK, RST and IO_C output. Therefore, the CLK, RST and IO_C output level is the same as the VCC output level.

5) I/O data transitions

The data line, IO_C - IO_U, transmits/receives two-way data.

The IO_U pin for the controller side is pulled up with an 11k Ω resistor to High (VDD voltage) and card contact pins IO_C is set to Lo until I/O TRANS becomes ON by the activation sequence.

When I/O TRANS becomes On, IC becomes idle mode and the I/O pin is pulled up with an 11k Ω resistor to keep the IO_U pin to VDD voltage (High) and the IO_C pin to VCC voltage (High).

The pin which turns to L from H first becomes the master and the other output side becomes the slave between the pins on the controller side and card contact pins. Then the data are transferred from the master side to the slave side.

When the both signal levels become High, they become idle mode.

When the signal transits from L to H and it passes over a threshold, an active pull-up (100 ns or less) works to drive the data High at high speed. After the active pull-up is completed, the pin is pulled up with an 11k Ω resistor. After the active pull-up is completed, the pin is pulled up with an 11k Ω resistor. This function enables signal transmission up to 1MHz. Also, an over-current limiter of 30mA in the card contact pin, IO_C.

6) Card clock supply

Card clock is supplied from the CLK pin dividing the input frequency of XTAL1 pin by 1/2 and 1/4 with the CLKSEL pin setting. The clock division switching time is within the 8 clocks of the XTAL1 signal.

The input signal to the XTAL1 pin is made by a crystal oscillator (16MHz) between the XTAL1 pin and XTAL2 pin or external pulse signal.

When a crystal oscillator is used, the voltage between XTAL1 and XTAL2 may decrease to become close to “-1V”, which is not a problem.

When an external pulse signal is applied to the XTAL1 pin (except for signal input by crystal oscillation), the transition time of the XTAL1 pin should be within 18% of the signal cycle to ensure the duty factor of 45% - 55% at the CLK pin.

Table 2 Clock frequency selection (f_{XTAL} : Frequency at XTAL1)

CLKSEL	f_{clk}
0	$\frac{f_{XTAL}}{4}$
1	$\frac{f_{XTAL}}{2}$

7) RSTIN input, RST output

The RSTIN input becomes effective after the CMDVCCB signal input turns to L from H, activation sequence is initiated and approximately 48 μ s after I/O TRANS turns ON. The RST output is released in approximately 472 μ sec (max. 481 μ sec) after the CMDVCCB signal turns from H to L to output a signal based on the RSTIN input.

8) Fault detection

When the following fault state is detected, the circuit enters the wait mode after it generates an internal alarm signal and is deactivated.

If a card is not present, it remains in the wait mode.

- When the VCC pin becomes less than 1.6V, or is loaded high current (TYP: 140mA)
- When VDDP voltage is less than the threshold voltage (detected by supply voltage detector)
- When a high temperature is detected by the thermal shutdown circuit
- When the card is removed during operation or the card is not present from the beginning (PRES=L and PRESB=H)

9) OFFB output

The OFFB output pin indicates the IC is ready to operate. It is pulled up to VDD with a 20k Ω resistor.

When the IC is in the ready state, OFFB is High.

After activation, the OFFB outputs OFF state (Lo) when a fault state is detected.

When a card is present and CMDVCCB becomes High, the internal alarm is released and the OFFB output becomes High.

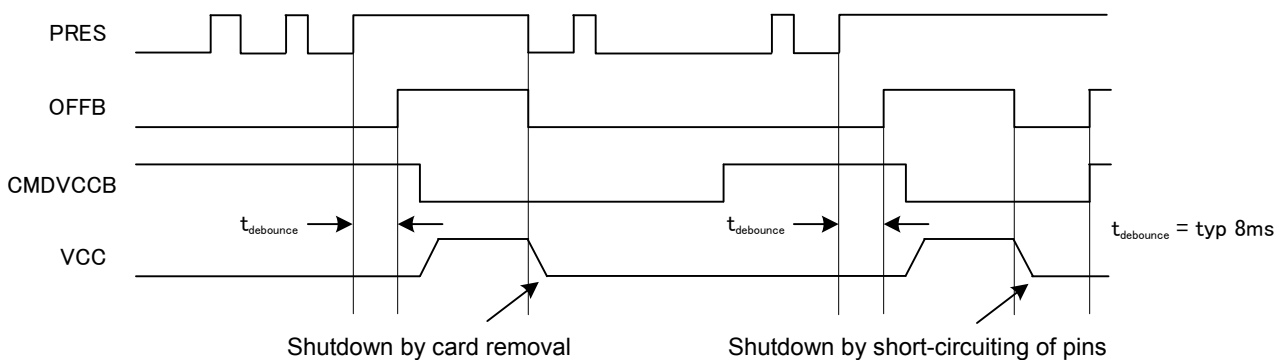

Fig. 6 OFFB, CMDVCCB, PRES, VCC operation

• An example of software control

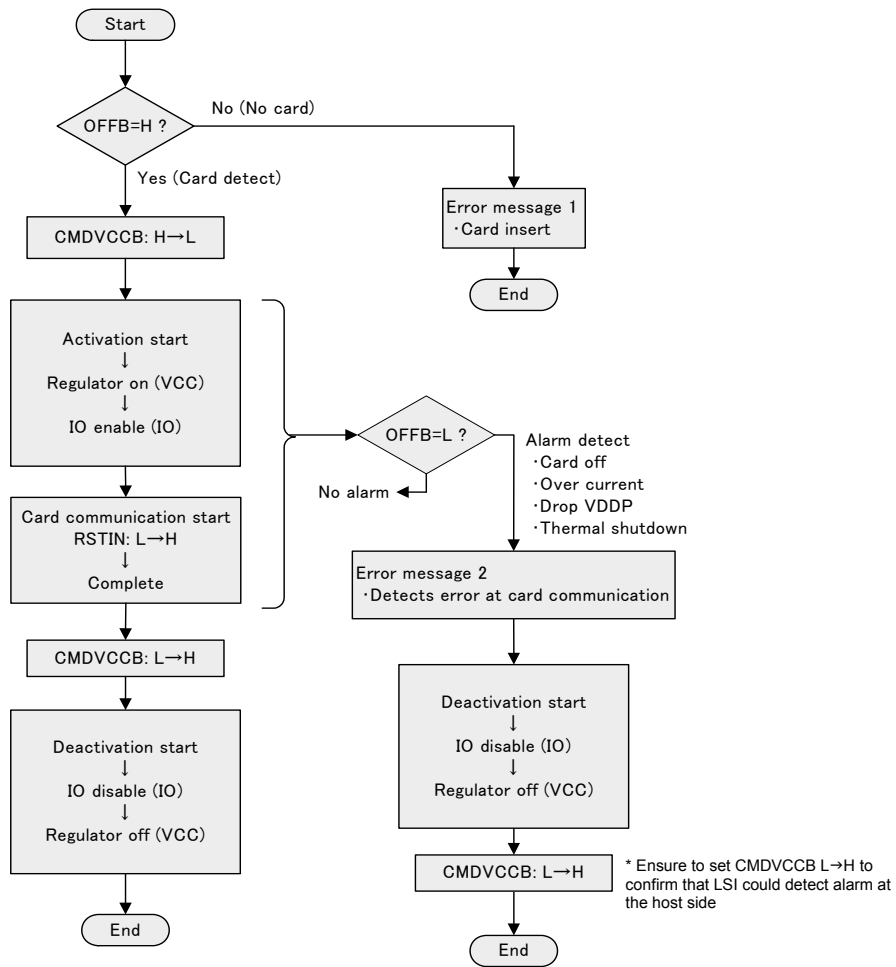

Fig. 7 An example of software control

- Application examples

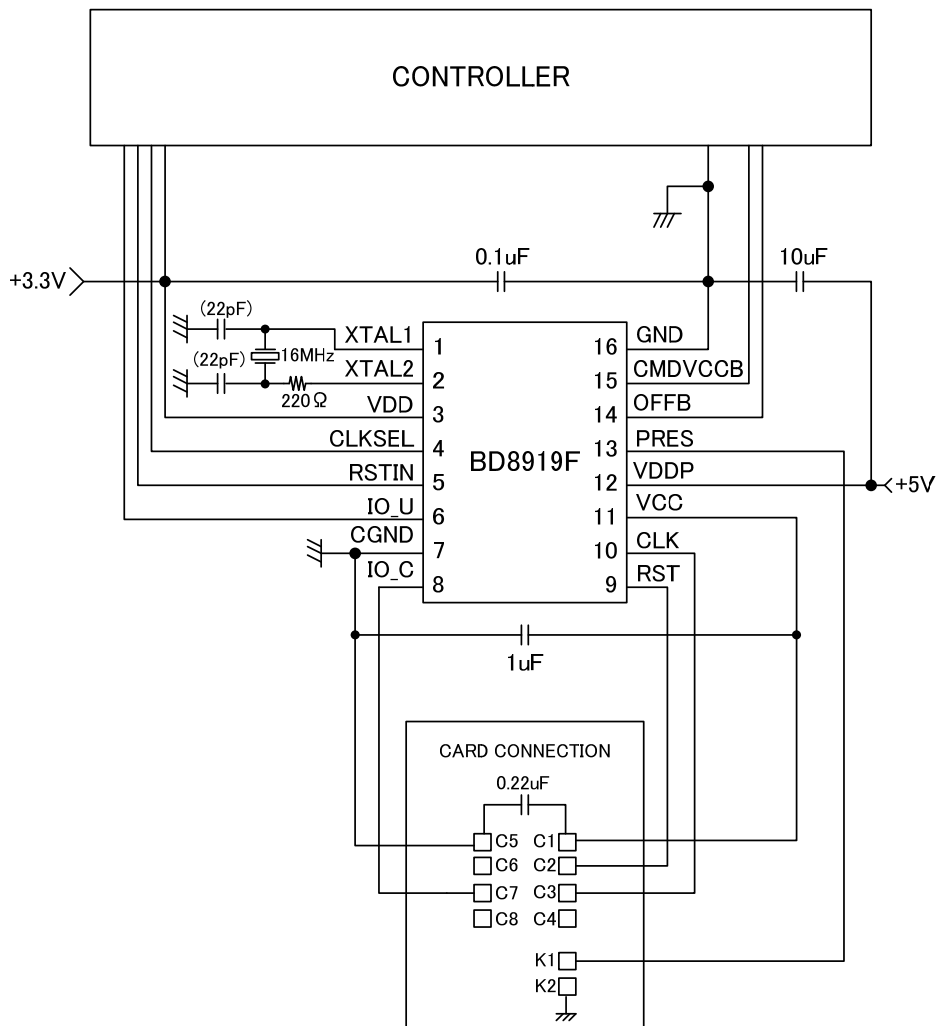
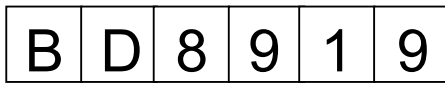

Fig. 8

- Precautions for use

- 1) The capacitor for the VCC pin should be placed as close as possible to the IC between VCC and CGND so that the ESR becomes less than 100mΩ.
- 2) Connect a capacitor of over 0.1μF for VDD and over 10μF for VDDP as close as possible to the IC so that the ESR becomes less than 100mΩ to reduce the power line noise. We recommend the use of capacitors with the largest possible capacitance.

●Selection of order type



ROHM model name



Package type

F : SOP16



Packaging and forming specification

E2 =Reel-shaped emboss taping

SOP16

<Dimension>

(Unit:mm)

<Tape and Reel information>

Tape	Embossed carrier tape
Quantity	2500pcs
Direction of feed	E2 (The direction is the 1pin of product is at the upper left when you hold reel on the left hand and you pull out the tape on the right hand)

Reel 1Pin Direction of feed

※When you order , please order in times the amount of package quantity.

The content specified in this document is correct as of 1st , 2009, January

No copying or reproduction of this document, in part or in whole, is permitted without the consent of ROHM CO.,LTD.

The content specified herein is subject to change for improvement without notice.

The content specified herein is for the purpose of introducing ROHM's products (hereinafter "Products"). If you wish to use any such Product, please be sure to refer to the specifications, which can be obtained from ROHM upon request.

Examples of application circuits, circuit constants and any other information contained herein illustrate the standard usage and operations of the Products. The peripheral conditions must be taken into account when designing circuits for mass production.

Great care was taken in ensuring the accuracy of the information specified in this document. However, should you incur any damage arising from any inaccuracy or misprint of such information, ROHM shall bear no responsibility for such damage.

The technical information specified herein is intended only to show the typical functions of and examples of application circuits for the Products. ROHM does not grant you, explicitly or implicitly, any license to use or exercise intellectual property or other rights held by ROHM and other parties. ROHM shall bear no responsibility whatsoever for any dispute arising from the use of such technical information.

The Products specified in this document are intended to be used with general-use electronic equipment or devices (such as audio visual equipment, office-automation equipment, communication devices, electronic appliances and amusement devices).

The Products are not designed to be radiation tolerant.

While ROHM always makes efforts to enhance the quality and reliability of its Products, a Product may fail or malfunction for a variety of reasons.

Please be sure to implement in your equipment using the Products safety measures to guard against the possibility of physical injury, fire or any other damage caused in the event of the failure of any Product, such as derating, redundancy, fire control and fail-safe designs. ROHM shall bear no responsibility whatsoever for your use of any Product outside of the prescribed scope or not in accordance with the instruction manual.

The Products are not designed or manufactured to be used with any equipment, device or system which requires an extremely high level of reliability the failure or malfunction of which may result in a direct threat to human life or create a risk of human injury (such as a medical instrument, transportation equipment, aerospace machinery, nuclear-reactor controller, fuel-controller or other safety device). ROHM shall bear no responsibility in any way for use of any of the Products for the above special purposes. If a Product is intended to be used for any such special purpose, please contact a ROHM sales representative before purchasing.

If you intend to export or ship overseas any Product or technology specified herein that may be controlled under the Foreign Exchange and the Foreign Trade Law, you will be required to obtain a license or permit under the Law.

ROHM Sales Offices

Contact us for further information about the products.

R0128A

San Diego +1-858-625-3630	United Kingdom +44-1-908-272400	Tianjin +86-22-23029181	Xiamen +86-592-238-5705
Atlanta +1-770-754-5972	Denmark +45-3694-4739	Shanghai +86-21-8279-2727	Zhuhai +86-756-3232-480
Boston +1-978-371-0382	Espoo +358-9725-54491	Hangzhou +86-571-87658072	Hong Kong +852-2-740-6262
Chicago +1-847-368-1006	Salo +358-2-7332234	Nanjing +86-25-8689-0015	Taipei +886-2-2500-6956
Dallas +1-972-473-3748	Oulu +358-8-5372930	Ningbo +86-574-87654201	Kaohsiung +886-7-237-0881
Denver +1-303-708-0908	Barcelona +34-9375-24320	Qingdao +86-532-8577-9312	Singapore +65-6332-2322
Detroit +1-248-348-9920	Hungary +36-1-4719338	Suzhou +86-512-6807-1300	Philippines +63-2-807-6872
Nashville +1-615-620-6700	Poland +48-22-5757213	Wuxi +86-510-82702693	Thailand +66-2-254-4890
Mexico +52-33-3123-2001	Russia +7-495-739-41-74	Guangzhou +86-20-3878-8100	Kuala Lumpur +60-3-7958-8355
Düsseldorf +49-2154-9210	Seoul +82-2-8182-700	Huizhou +86-752-205-1054	Penang +60-4-2286453
Munich +49-8999-216168	Masan +82-55-240-6234	Fuzhou +86-591-8801-8698	Kyoto +81-75-365-1218
Stuttgart +49-711-7272-370	Dalian +86-411-8230-8549	Dongguan +86-769-8393-3320	Yokohama +81-45-476-2290
France +33-1-5697-3060	Beijing +86-10-8525-2483	Shenzhen +86-755-8307-3008	

ROHM Co.,Ltd.

21 Saini Mizosaki-cho, Ukyo-ku,
Kyoto 615-8585 Japan

TEL : +81-75-311-2121 FAX : +81-75-315-0172

www.rohm.com



Notes

No copying or reproduction of this document, in part or in whole, is permitted without the consent of ROHM CO.,LTD.

The content specified herein is subject to change for improvement without notice.

The content specified herein is for the purpose of introducing ROHM's products (hereinafter "Products"). If you wish to use any such Product, please be sure to refer to the specifications, which can be obtained from ROHM upon request.

Examples of application circuits, circuit constants and any other information contained herein illustrate the standard usage and operations of the Products. The peripheral conditions must be taken into account when designing circuits for mass production.

Great care was taken in ensuring the accuracy of the information specified in this document. However, should you incur any damage arising from any inaccuracy or misprint of such information, ROHM shall bear no responsibility for such damage.

The technical information specified herein is intended only to show the typical functions of and examples of application circuits for the Products. ROHM does not grant you, explicitly or implicitly, any license to use or exercise intellectual property or other rights held by ROHM and other parties. ROHM shall bear no responsibility whatsoever for any dispute arising from the use of such technical information.

The Products specified in this document are intended to be used with general-use electronic equipment or devices (such as audio visual equipment, office-automation equipment, communication devices, electronic appliances and amusement devices).

The Products are not designed to be radiation tolerant.

While ROHM always makes efforts to enhance the quality and reliability of its Products, a Product may fail or malfunction for a variety of reasons.

Please be sure to implement in your equipment using the Products safety measures to guard against the possibility of physical injury, fire or any other damage caused in the event of the failure of any Product, such as derating, redundancy, fire control and fail-safe designs. ROHM shall bear no responsibility whatsoever for your use of any Product outside of the prescribed scope or not in accordance with the instruction manual.

The Products are not designed or manufactured to be used with any equipment, device or system which requires an extremely high level of reliability the failure or malfunction of which may result in a direct threat to human life or create a risk of human injury (such as a medical instrument, transportation equipment, aerospace machinery, nuclear-reactor controller, fuel-controller or other safety device). ROHM shall bear no responsibility in any way for use of any of the Products for the above special purposes. If a Product is intended to be used for any such special purpose, please contact a ROHM sales representative before purchasing.

If you intend to export or ship overseas any Product or technology specified herein that may be controlled under the Foreign Exchange and the Foreign Trade Law, you will be required to obtain a license or permit under the Law.

Thank you for your accessing to ROHM product informations.

More detail product informations and catalogs are available, please contact your nearest sales office.

ROHM Customer Support System

THE AMERICAS / EUROPE / ASIA / JAPAN

www.rohm.com

Contact us : webmaster@rohm.co.jp