

Structure Silicon monolithic integrated circuit  
 Product High-side N-channel MOSFET driver IC  
 Type **BD2270HFV**  
 Features  
 Charge pump circuit included for drive external N-channel MOSFET  
 Output discharge circuit  
 Soft start circuit  
 Hysteresis comparator input: H-Active

◇Absolute maximum ratings (Ta = 25°C)

Parameter	Symbol	Rating	Unit
Supply voltage	V <sub>CC</sub>	-0.3 ~ 6.0	V
AEN voltage	V <sub>AEN</sub>	-0.3 ~ 6.0	V
GATE voltage	V <sub>GATE</sub>	-0.3 ~ 15.0	V
DISC voltage	V <sub>DISC</sub>	-0.3 ~ 6.0	V
Storage temperature	T <sub>STG</sub>	-55 ~ 150	°C
Power dissipation	P <sub>d</sub>	669 <sup>*1</sup>	mW

\*1 Mounted on 70mm \* 70mm \* 1.6mm glass-epoxy PCB. Derating : 5.352mW/°C for operating above Ta = 25°C.

\* This product is not designed for protection against radioactive rays.

◇Operating conditions

Parameter	Symbol	MIN	TYP	MAX	Unit
Supply voltage	V <sub>CC</sub>	2.7	3.0	5.5	V
Operating temperature	T <sub>OPR</sub>	-25	-	85	°C

Status of this document

The Japanese version of this document is the formal specification. A customer may use this translation version only for a reference to help reading the formal version.

If there are any differences in translation version of this document, formal version takes priority.

Application example

- ROHM cannot provide adequate confirmation of patents.
- The product described in this specification is designed to be used with ordinary electronic equipment or devices (such as audio-visual equipment, office-automation equipment, communications devices, electrical appliances, and electronic toys).  
Should you intend to use this product with equipment or devices which require an extremely high level of reliability and the malfunction of which would directly endanger human life (such as medical instruments, transportation equipment, aerospace machinery, nuclear-reactor controllers, fuel controllers and other safety devices), please be sure to consult with our sales representative in advance.
- ROHM assumes no responsibility for use of any circuits described herein, conveys no license under any patent or other right, and makes no representations that the circuits are free from patent infringement.

DESIGN	CHECK	APPROVAL	DATE : 2007/11/26	SPECIFICATION No. : TSZ02201-BD2270HFV-1-2
<i>H. Matsubara</i>	<i>M. Komai</i>	<i>T. Yamaguchi</i>	REV. B	<b>ROHM CO., LTD.</b>

◇ Electric characteristics

Unless otherwise specified  $V_{CC} = 3V$ ,  $T_a = 25^\circ C$

Parameter	Symbol	Limits			Unit	Condition
		MIN	TYP	MAX		
Operating current	$I_{CC}$	-	50	75	$\mu A$	$V_{AEN} = 2.5V$
Standby current	$I_{STB}$	-	5	10	$\mu A$	$V_{AEN} = 0V$
AEN input voltage	$V_{AENH}$	1.55	2.0	2.45	V	High level input
	$V_{AENL}$	1.35	1.9	2.35	V	Low level input
AEN input current	$I_{AEN}$	-	3	5	$\mu A$	$V_{AEN} = 3V$
GATE voltage	$V_{GATE}$	10	13.5	15.0	V	$V_{CC} = 5V$
		6.6	9.5	9.9	V	$V_{CC} = 3.3V$
		6	8.5	9	V	$V_{CC} = 3V$
GATE Turn on time	$T_{ON}$	-	130	750	$\mu s$	$C_{GATE} = 500pF$ $V_{CC} = 3V$ $V_{GATE} > 4V$
GATE Turn off time	$T_{OFF}$	-	18	60	$\mu s$	$C_{GATE} = 500pF$ $V_{CC} = 3V$ $V_{GATE} < 0.5V$
DISC ON resistance	$R_{DISC}$	-	200	350	$\Omega$	$V_{AEN} = 0V$

◇ Test circuit

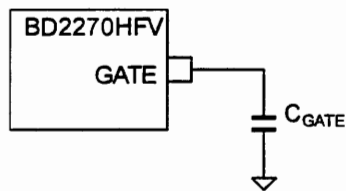

◇ GATE turn on and turn off times

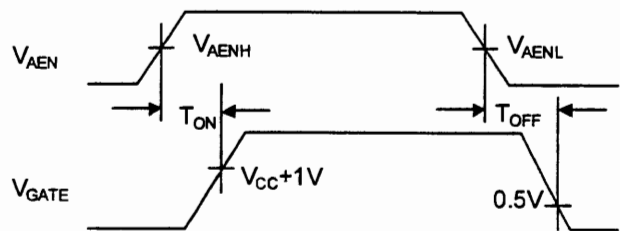

◇Block diagram

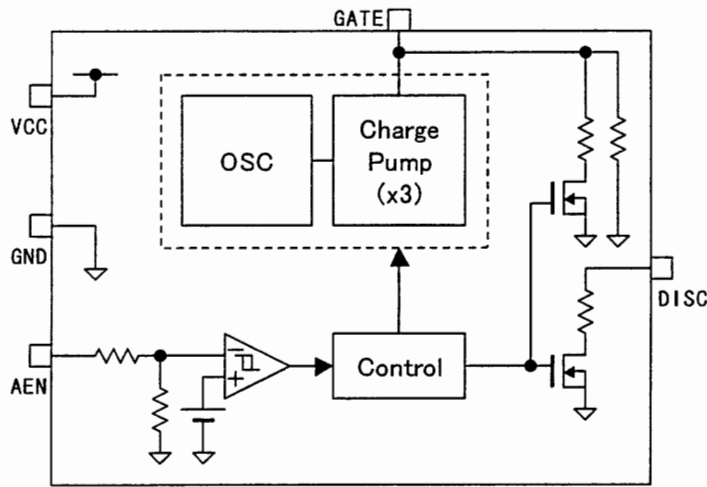

◇Pin description

Pin Number	Pin Name
1	VCC
2	GND
3	AEN
4	DISC
5	GATE

◇Package

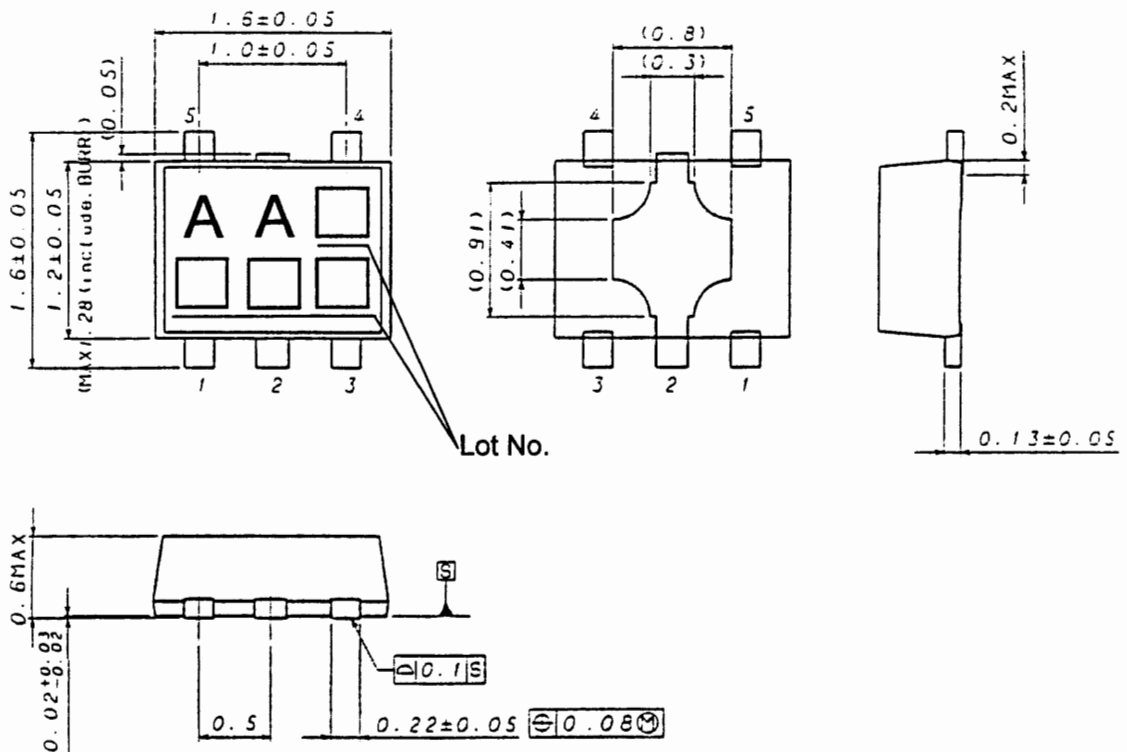

HVSO5  
Unit (mm)

## ○Cautions on use

## (1) Absolute Maximum Ratings

An excess in the absolute maximum ratings, such as supply voltage, temperature range of operating conditions, etc., can break down devices, thus making impossible to identify breaking mode such as a short circuit or an open circuit. If any special mode exceeding the absolute maximum ratings is assumed, consideration should be given to take physical safety measures including the use of fuses, etc.

## (2) Power supply and GND line

Design PCB pattern to provide low impedance for the wiring between the power supply and the GND lines. Pay attention to the interference by common impedance of layout pattern when there are plural power supplies and GND lines. Especially, when there are GND pattern for small signal and GND pattern for large current included the external circuits, separate each GND pattern. Furthermore, for all power supply terminals to ICs, mount a capacitor between the power supply and the GND terminal. At the same time, in order to use a capacitor, thoroughly check to be sure the characteristics of the capacitor to be used present no problem including the occurrence of capacity dropout at a low temperature, thus determining the constant.

## (3) GND voltage

Make setting of the potential of the GND terminal so that it will be maintained at the minimum in any operating state. Furthermore, check to be sure no terminals are at a potential lower than the GND voltage including an actual electric transient.

## (4) Short circuit between terminals and erroneous mounting

In order to mount ICs on a set PCB, pay thorough attention to the direction and offset of the ICs. Erroneous mounting can break down the ICs. Furthermore, if a short circuit occurs due to foreign matters entering between terminals or between the terminal and the power supply or the GND terminal, the ICs can break down.

## (5) Operation in strong electromagnetic field

Be noted that using ICs in the strong electromagnetic field can malfunction them.

## (6) Input terminals

In terms of the construction of IC, parasitic elements are inevitably formed in relation to potential. The operation of the parasitic element can cause interference with circuit operation, thus resulting in a malfunction and then breakdown of the input terminal. Therefore, pay thorough attention not to handle the input terminals, such as to apply to the input terminals a voltage lower than the GND respectively, so that any parasitic element will operate. Furthermore, do not apply a voltage to the input terminals when no power supply voltage is applied to the IC. In addition, even if the power supply voltage is applied, apply to the input terminals a voltage lower than the power supply voltage or within the guaranteed value of electrical characteristics.

## (7) External capacitor

In order to use a ceramic capacitor as the external capacitor, determine the constant with consideration given to a degradation in the nominal capacitance due to DC bias and changes in the capacitance due to temperature, etc.

## (8) Thermal design

Perform thermal design in which there are adequate margins by taking into account the power dissipation (PD) in actual states of use.