

## TECHNICAL NOTES

### Ultra-small Hall IC Series for Magnetic Switches

# Bipolar Detection Hall ICs

## BU52001GUL/BU52011HFV/BU52021HFV/BU52015GUL

---

### ●Description

The BU52001GUL, BU52011HFV, BU52021HFV and BU52015GUL bipolar Hall ICs for magnetic switches feature both S-and N-pole operation, outputting High to Low. We also offer a lineup of dual-output units with a reverse output terminal (active High).

### ●Features

- 1) Bipolar detection
- 2) Ultra-low power operation (small current via intermittent operation)
- 3) Ultra-compact CSP4 package (BU52001GUL, BU52015GUL)
- 4) Compact package (BU52011HFV, BU52021HFV)
- 5) Supports 1.8V supply voltage (BU52011HFV, BU52015GUL)
- 6) Dual-output type (BU52015GUL)
- 7) High ESD resistance: 8kV (HBM)

### ●Applications

Mobile phones, notebook computers, digital video cameras, digital cameras, and more.

### ●Product Lineup

Part Number	Supply Voltage (V)	Operating Point (mT)	Hysteresis (mT)	Period (ms)	Supply Current (Ave.) ( $\mu$ A)	Output Type	Package
BU52001GUL	2.40~3.30	+/-3.7 ※	0.8	50	8.0	CMOS	VCSP50L1
BU52011HFV	1.65~3.30	+/-3.0 ※	0.9	50	5.0	CMOS	HVSOF5
BU52021HFV	2.40~3.60	+/-3.7 ※	0.8	50	8.0	CMOS	HVSOF5
BU52015GUL	1.65~3.30	+/-3.0 ※	0.9	50	5.0	CMOS	VCSP50L1

※Plus and minus indicate the S-pole N-pole, respectively

● Absolute Maximum Ratings

BU52001GUL, BU52021HFV (Ta=25°C)

Parameter	Symbol	Limits	Unit
Power supply voltage	V <sub>DD</sub>	-0.1~4.5	V
Output current	I <sub>OUT</sub>	±1	mA
Operating temp. range	T <sub>opr</sub>	-40~85	°C
Storage temp. range	T <sub>stg</sub>	-40~125	°C

BU52011HFV, BU52015GUL (Ta=25°C)

Parameter	Symbol	Limits	Unit
Power supply voltage	V <sub>DD</sub>	-0.1~4.5	V
Output current	I <sub>OUT</sub>	±0.5	mA
Operating temp. range	T <sub>opr</sub>	-40~85	°C
Storage temp. range	T <sub>stg</sub>	-40~125	°C

● Magnetic and Electrical Characteristics

BU52001GUL (V<sub>DD</sub>=3.0V, Ta=25°C)

Parameter	Symbol	Specified Values			Unit	Conditions
		Min.	Typ.	Max.		
Supply voltage	V <sub>DD</sub>	2.4	3.0	3.3	V	
Operating point	B <sub>opS</sub>	-	3.7	5.5	mT	
	B <sub>opN</sub>	-5.5	-3.7	-		
Release point	B <sub>rpS</sub>	0.8	2.9	-	mT	
	B <sub>rpN</sub>	-	-2.9	-0.8		
Period	T <sub>p</sub>	-	50	100	ms	
Output high voltage	V <sub>OH</sub>	V <sub>DD</sub> -0.4	-	-	V	B <sub>rpN</sub> <B<B <sub>rpS</sub> I <sub>OUT</sub> = -1.0mA ※
Output low voltage	V <sub>OL</sub>	-	-	0.4	V	B<B <sub>opN</sub> , B <sub>opS</sub> <B I <sub>OUT</sub> = +1.0mA ※
Supply current	I <sub>DD(AVG)</sub>	-	8.0	12.0	μA	Average values

BU52011HFV (V<sub>DD</sub>=1.80V, Ta=25°C)

Parameter	Symbol	Specified Values			Unit	Conditions
		Min.	Typ.	Max.		
Supply voltage	V <sub>DD</sub>	1.65	1.80	3.30	V	
Operating point	B <sub>opS</sub>	-	3.0	5.0	mT	
	B <sub>opN</sub>	-5.0	-3.0	-		
Release point	B <sub>rpS</sub>	0.6	2.1	-	mT	
	B <sub>rpN</sub>	-	-2.1	-0.6		
Period	T <sub>p</sub>	-	50	100	ms	
Output high voltage	V <sub>OH</sub>	V <sub>DD</sub> -0.2	-	-	V	B <sub>rpN</sub> <B<B <sub>rpS</sub> I <sub>OUT</sub> = -0.5mA ※
Output low voltage	V <sub>OL</sub>	-	-	0.2	V	B<B <sub>opN</sub> , B <sub>opS</sub> <B I <sub>OUT</sub> = +0.5mA ※
Supply current 1	I <sub>DD1(AVG)</sub>	-	5.0	8.0	μA	V <sub>DD</sub> =1.8V, Average values
Supply current 2	I <sub>DD2(AVG)</sub>	-	8.0	12.0	μA	V <sub>DD</sub> =2.7V, Average values

※B = Magnetic flux density

1mT=10Gauss

The output is fixed after one period from power ON.

These products are not designed to be resistant to radiation.

BU52021HFV ( $V_{DD}=3.0V$ ,  $T_a=25^{\circ}C$ )

Parameter	Symbol	Specified Values			Unit	Conditions
		Min.	Typ.	Max.		
Supply voltage	$V_{DD}$	2.4	3.0	3.6	V	
Operating point	$B_{opS}$	-	3.7	5.5	mT	
	$B_{opN}$	-5.5	-3.7	-		
Release point	$B_{rpS}$	0.8	2.9	-	mT	
	$B_{rpN}$	-	-2.9	-0.8		
Period	$T_p$	-	50	100	ms	
Output high voltage	$V_{OH}$	$V_{DD}$ -0.4	-	-	V	$B_{rpN} < B < B_{rpS}$ $I_{OUT} = -1.0mA$ ※
Output low voltage	$V_{OL}$	-	-	0.4	V	$B < B_{opN}$ , $B_{opS} < B$ $I_{OUT} = +1.0mA$ ※
Supply current	$I_{DD(AVG)}$	-	8.0	12.0	$\mu A$	Average values

BU52015GUL ( $V_{DD}=1.80V$ ,  $T_a=25^{\circ}C$ )

Parameter	Symbol	Specified Values			Unit	Conditions
		Min.	Typ.	Max.		
Supply voltage	$V_{DD}$	1.65	1.80	3.30	V	
Operating point	$B_{opS}$	-	3.0	5.0	mT	
	$B_{opN}$	-5.0	-3.0	-		
Release point	$B_{rpS}$	0.6	2.1	-	mT	
	$B_{rpN}$	-	-2.1	-0.6		
Period	$T_p$	-	50	100	ms	
Output high voltage	$V_{OH}$	$V_{DD}$ -0.2	-	-	V	OUT1: $B_{rpN} < B < B_{rpS}$ ※ OUT2: $B < B_{opN}$ , $B_{opS} < B$ $I_{OUT} = -0.5mA$
Output low voltage	$V_{OL}$	-	-	0.2	V	OUT1: $B < B_{opN}$ , $B_{opS} < B$ ※ OUT2: $B_{rpN} < B < B_{rpS}$ $I_{OUT} = +0.5mA$
Supply current 1	$I_{DD1(AVG)}$	-	5.0	8.0	$\mu A$	$V_{DD}=1.8V$ , Average values
Supply current 2	$I_{DD2(AVG)}$	-	8.0	12.0	$\mu A$	$V_{DD}=2.7V$ , Average values

※B = Magnetic flux density

1mT=10Gauss

The output is fixed after one period from power ON.

These products are not designed to be resistant to radiation.

● Technical Data (Reference)

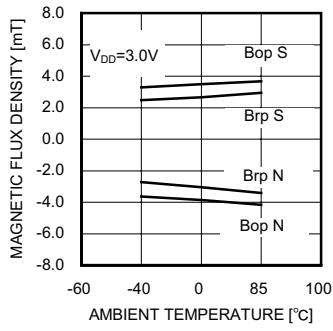

Fig.1 BU52001GUL  
Bop,Brp–Ambient temperature

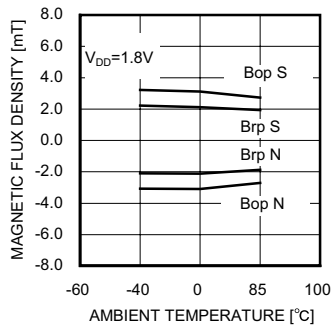

Fig.2 BU52011HFV  
BU52015GUL  
Bop,Brp– Ambient temperature

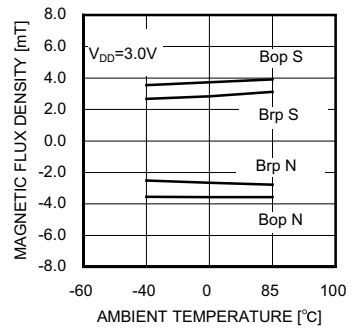

Fig.3 BU52021HFV  
Bop,Brp– Ambient temperature

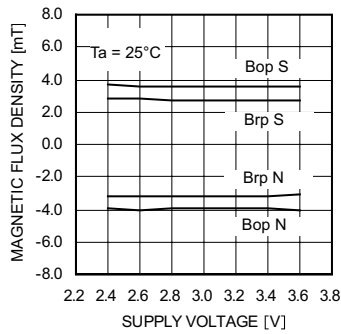

Fig.4 BU52001GUL  
Bop,Brp– Supply voltage

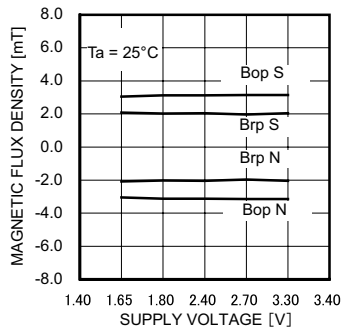

Fig.5 BU52011HFV  
BU52015GUL  
Bop,Brp– Supply voltage

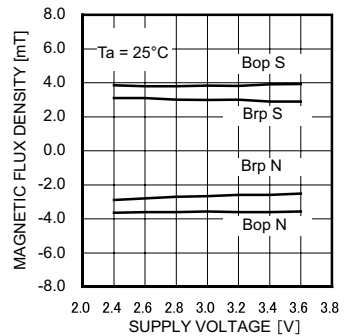

Fig.6 BU52021HFV  
Bop,Brp– Supply voltage

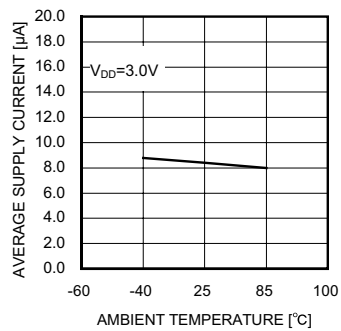

Fig.7 BU52001GUL  
Average supply current  
– Ambient temperature

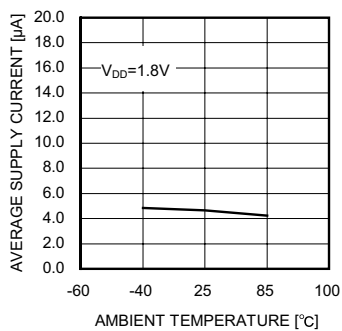

Fig.8 BU52011HFV  
BU52015GUL  
Average supply current  
– Ambient temperature

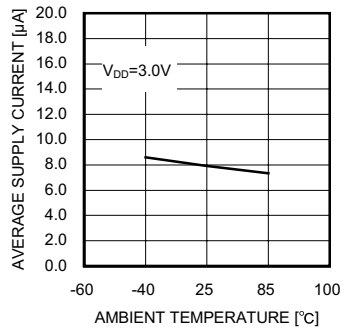

Fig.9 BU52021HFV  
Average supply current  
– Ambient temperature

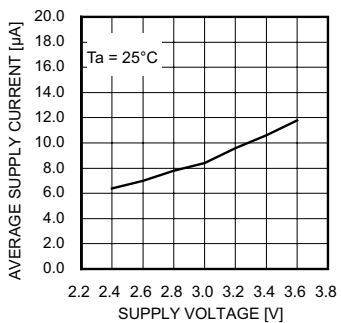

Fig.10 BU52001GUL  
Average supply current  
– Supply voltage

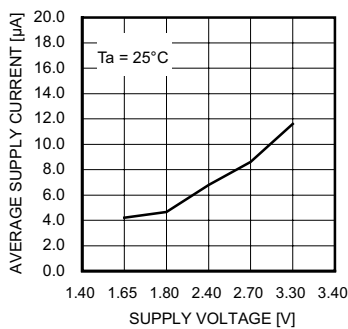

Fig.11 BU52011HFV  
BU52015GUL  
Average supply current  
– Supply voltage

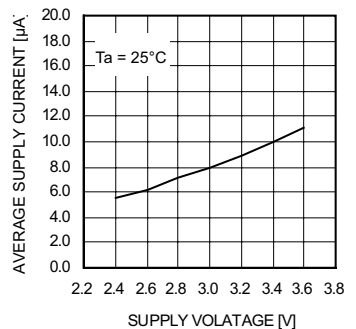

Fig.12 BU52021HFV  
Average supply current  
– Supply voltage

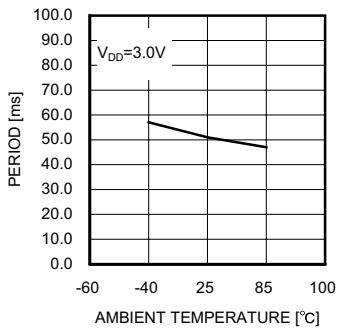

Fig.13 BU52001GUL  
Period  
– Ambient temperature

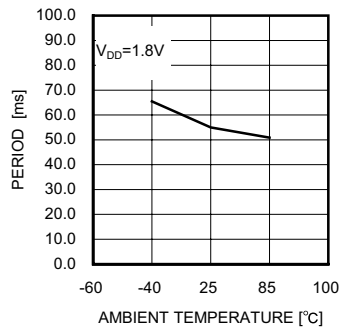

Fig.14 BU52011HFV  
BU52015GUL  
Period  
– Ambient temperature

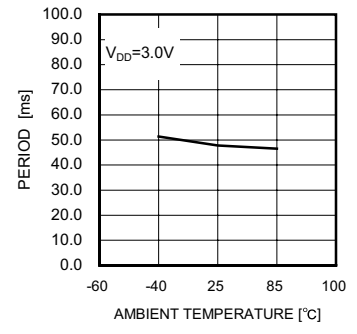

Fig.15 BU52021HFV  
Period  
– Ambient temperature

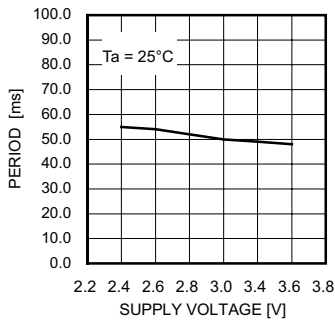

Fig.16 BU52001GUL  
Period – Supply voltage

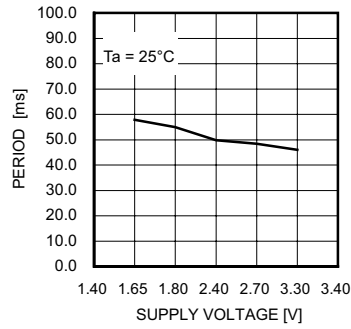

Fig.17 BU52011HFV  
BU52015GUL  
Period – Supply voltage

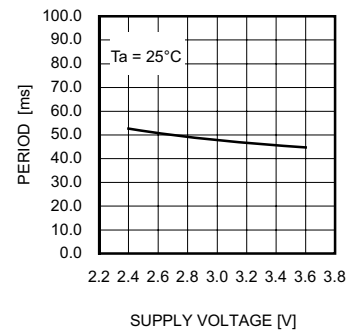

Fig.18 BU52021HFV  
Period – Supply voltage

● Block Diagram  
BU52001GUL

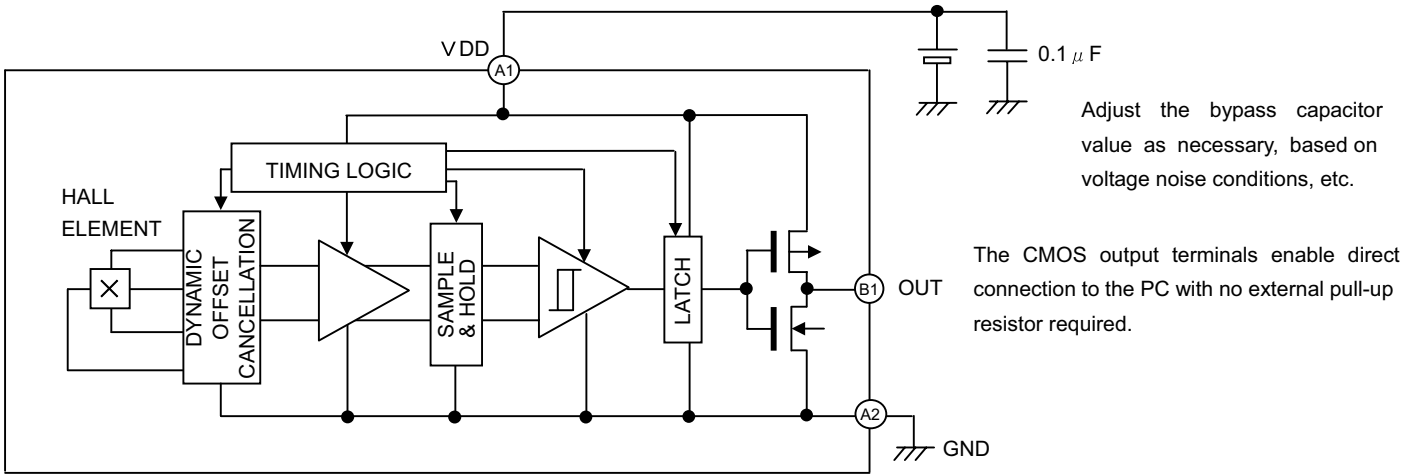
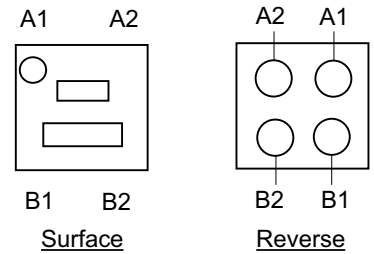

Fig.19

Pin.No.	Pin	Description	Remarks
A1	VDD	Power supply	
A2	GND	GROUND	
B1	OUT	Output pin	
B2	N.C.	-	Short to OPEN or GND



BU52011HFV, BU52021HFV

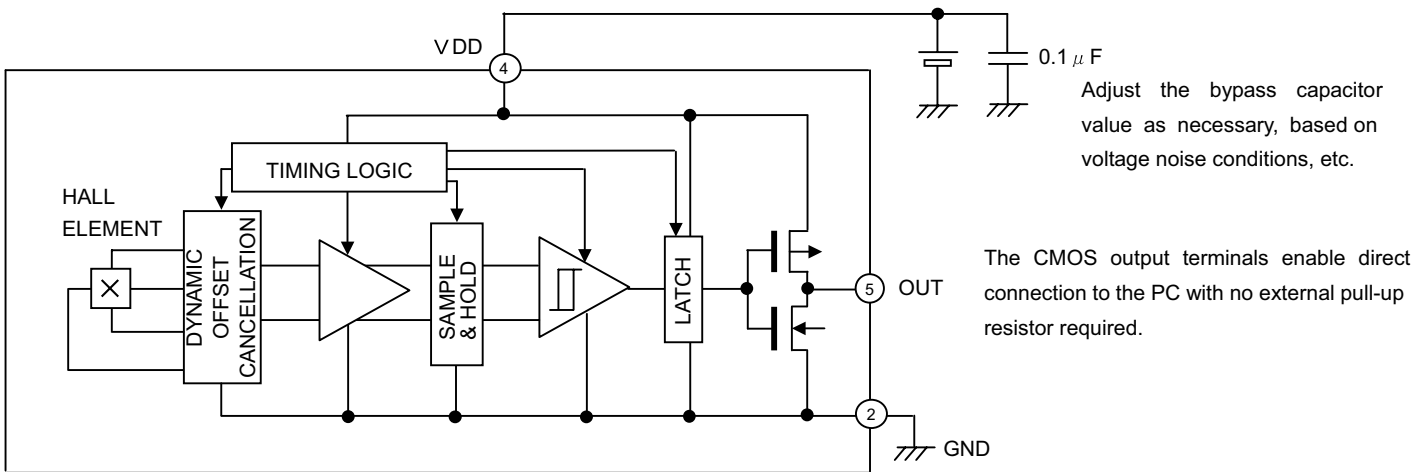
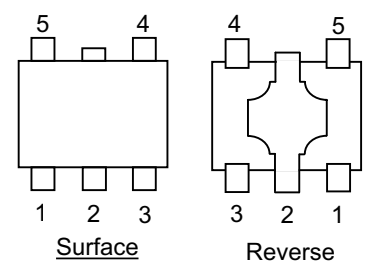

Fig.20

Pin.No	Pin	Description	Remarks
1	N.C.	N.C.	Short to OPEN or to GND
2	GND	GROUND	
3	N.C.	N.C.	Short to OPEN or to GND
4	VDD	Power supply	
5	OUT	Output pin	



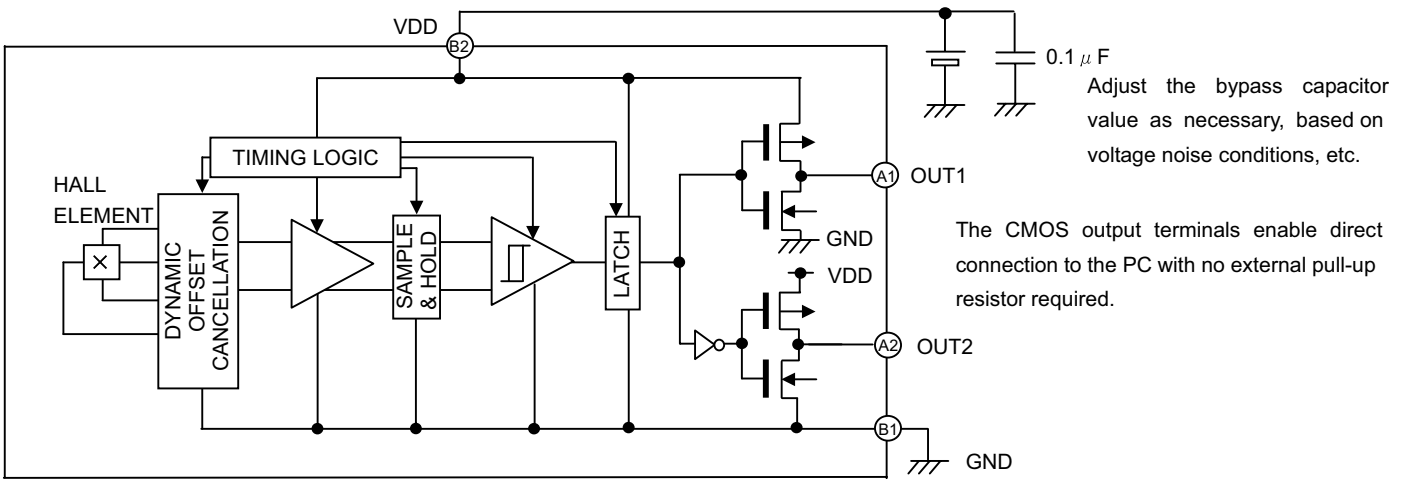
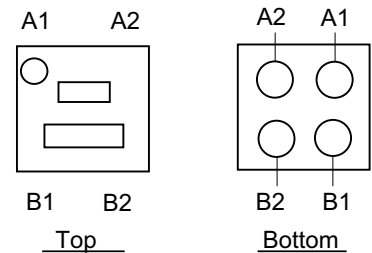

Fig.21

Pin.No	Pin	Description	Remarks
A1	OUT1	Output pin (Active Low)	
A2	OUT2	Output pin (Active High)	
B1	GND	GROUND	
B2	VDD	Power supply	



●Description of Operation

(Ultra-low Power Operation)

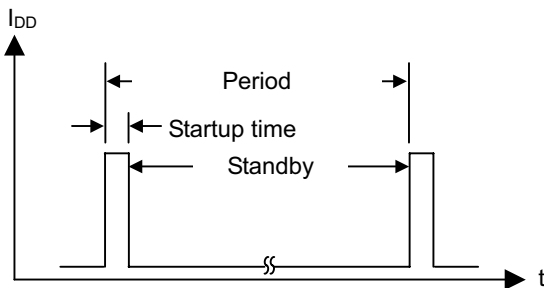

Fig.22

The bipolar detection Hall IC utilizes an intermittent operation method to save energy. At startup, the Hall elements, amp, comparator and other detection circuits power ON and magnetic detection begins. During standby, the detection circuits power OFF, reducing current consumption. The detection results are held while standby is active, and then output.

Reference period: 50ms (100ms Max.)  
Reference startup time: 48 μs

(Offset Cancellation)

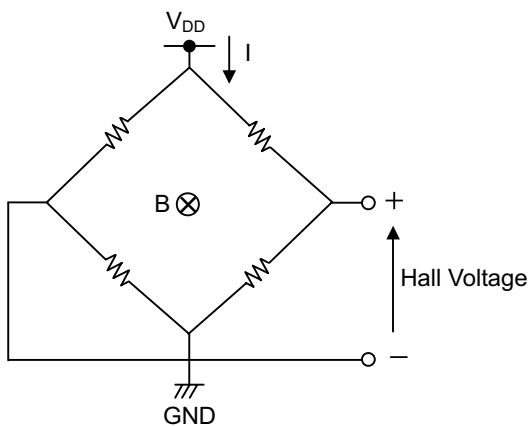

Fig.23

The Hall elements form an equivalent Wheatstone (resistor) bridge circuit. Offset voltage may be generated by a differential in this bridge resistance, or can arise from changes in resistance due to package or bonding stress. A dynamic offset cancellation circuit is employed to cancel this offset voltage.

When Hall elements are connected as shown in Fig. 23 and a magnetic field is applied perpendicular to the Hall elements voltage is generated at the mid-point terminal of the bridge. This is known as Hall voltage.

Dynamic cancellation switches the wiring (shown in the figure) to redirect the current flow to a 90° angle from its original path, cancelling the Hall voltage.

The magnetic signal (only) is maintained in the sample/hold circuit during the offset cancellation process, then released

(Magnetic Field Detection Mechanism)

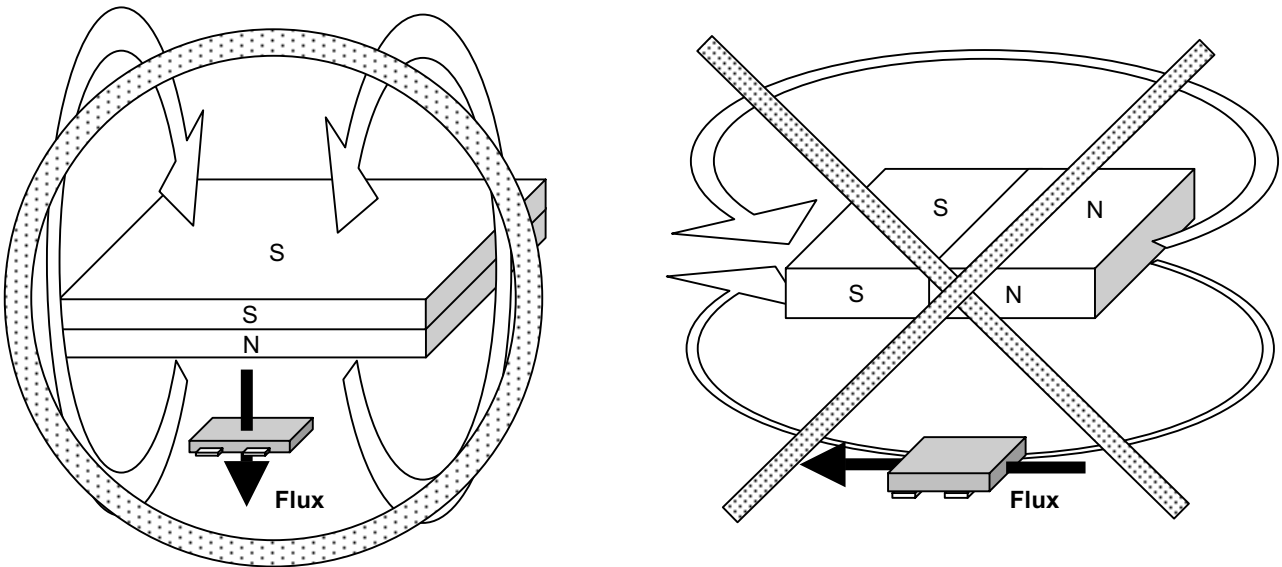

Fig.24

The Hall IC cannot detect magnetic fields that run horizontal to the package top layer. Therefore, ensures that the Hall IC is configured perpendicular to the top layer.

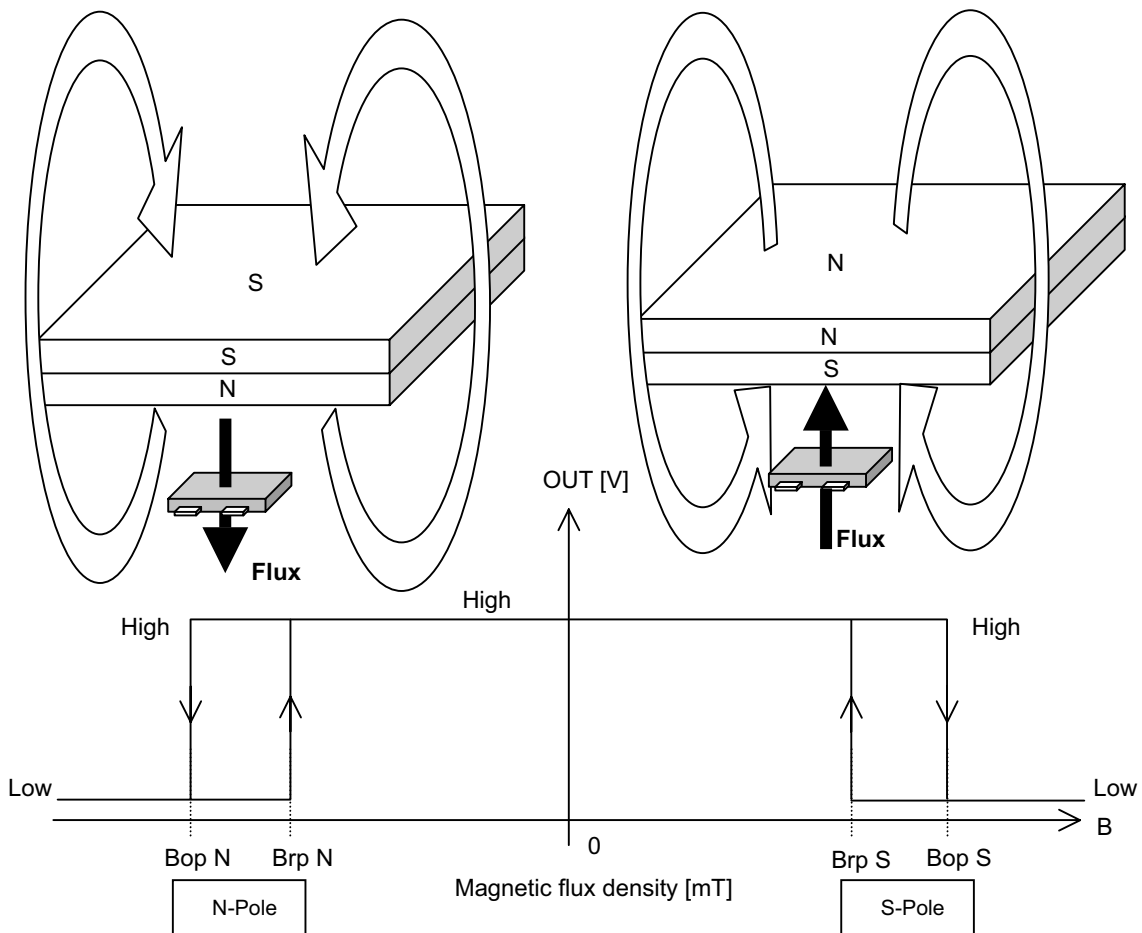

Fig.25

The bipolar detection Hall IC detects magnetic fields running perpendicular to the top surface of the package. There is an inverse relationship between magnetic flux density and the distance separating the magnet and the Hall IC: when distance increases magnetic density falls. When it drops below the operating point (Bop), the output goes HIGH. As the magnet gets closer to the IC and the magnetic density rises to the operating point the output switches LOW. In LOW output mode the distance from the magnet to the IC increases again until the magnetic density falls to a point just below Bop, when the output returns HIGH. (This point, where the magnetic flux density restores HIGH output, is known as the release point, Brp.) This detection and adjustment mechanism is designed to prevent noise, oscillation and other erratic system operation.

● Intermittent Operation at Power ON

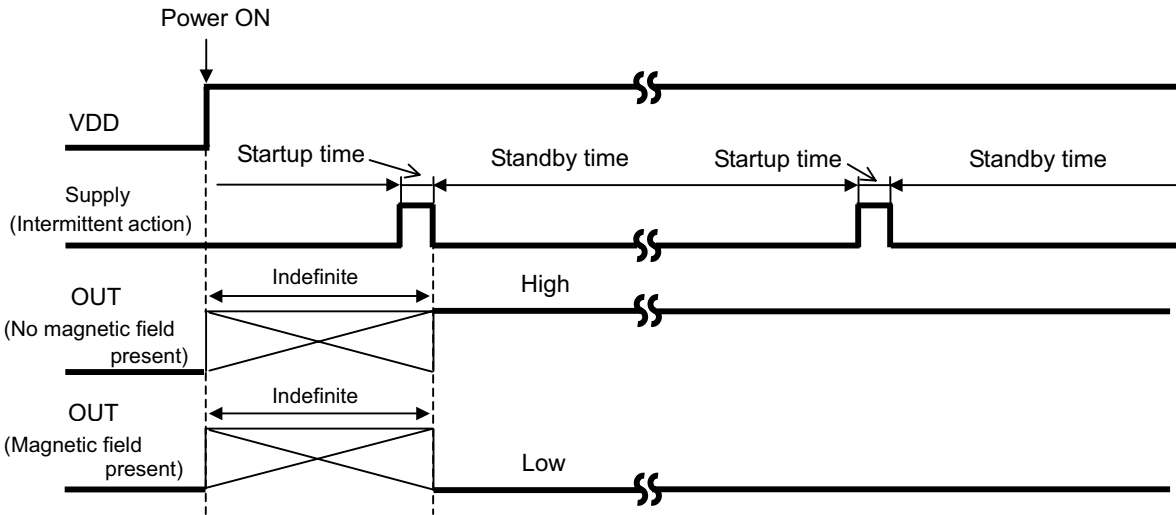

Fig.26

The bipolar detection Hall IC utilizes an intermittent operation method to detect the magnetic field during startup, as shown in Fig. 26. It outputs to the appropriate terminal based on the detection result and maintains the output condition during the standby period. The time from power ON until the end of the initial startup period is an indefinite interval, but it cannot exceed the maximum period, 100ms. To accommodate the system design, the Hall IC output read should be programmed within 100ms of power ON, but after the time allowed for the period for ambient temperature and supply voltage.

● Magnet Selection

Of the two varieties of permanent magnets available, neodymium generally offers greater magnetic power per volume than ferrite, thereby enabling the highest degree of miniaturization. Thus, neodymium is best suited for small equipment applications. Fig. 27 shows the relation between the size (volume) of a neodymium magnet and magnetic flux density. The graph plots the correlation between the distance (L) from three versions of a 4mm X 4mm cross-section neodymium magnet (1mm, 2mm, and 3mm thick) and magnetic flux density. Fig. 28 shows Hall IC detection distance – a good guide for determining the proper size and detection distance of the magnet. Based on the maximum operating point of 5.0 mT (BU52011HFV, BU52015GUL), the minimum detection distance for the 1mm, 2mm and 3mm magnets are 7.6mm, 9.22mm, and 10.4mm, respectively. To increase the magnet's detection distance, either increase its thickness or sectional area.

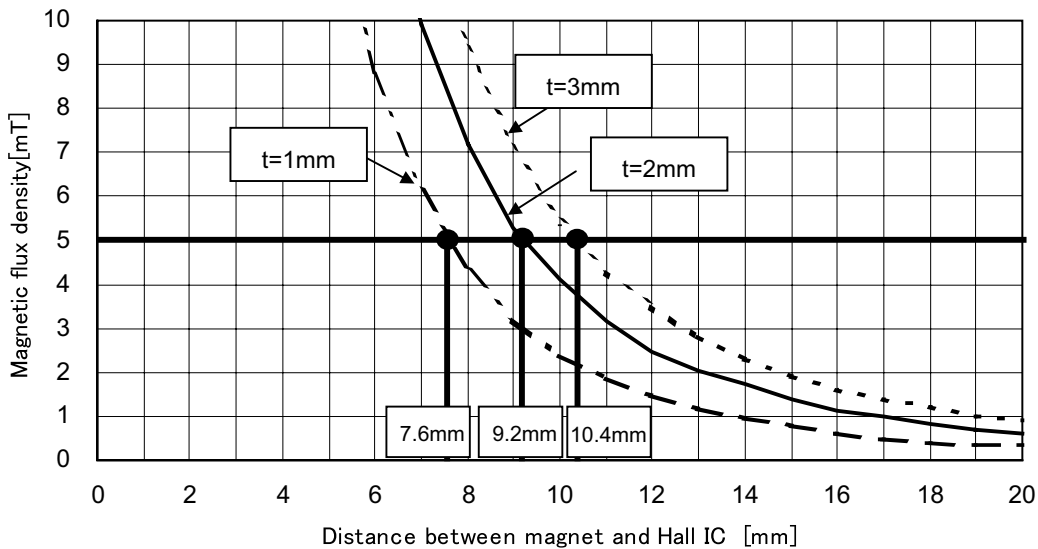

Fig.27

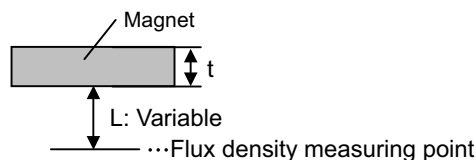
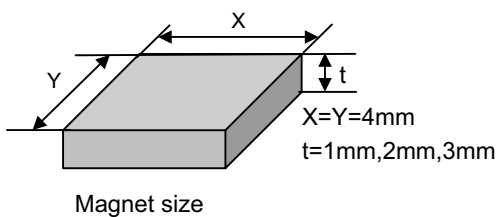

Fig.28 Magnet Dimensions and Flux Density Measuring Point

● Terminal Equivalent Circuit Diagram

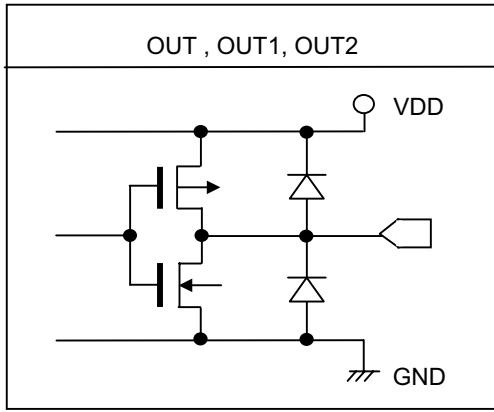

Fig.29

Since they are configured for CMOS (inverter) output, the output pins require no external resistance and allow direct connection to the PC. This, in turn, enables reduction of the current that would otherwise flow to the external resistor during magnetic field detection and supports overall low current (micropower) operation.

● Operation Notes

1) Absolute maximum ratings

Exceeding the absolute maximum ratings for supply voltage, operating conditions, etc. may result in damage to or destruction of the IC. Because the source (short mode or open mode) cannot be identified if the device is damaged in this way, it is important to take physical safety measures such as fusing when implementing any special mode that operates in excess of the absolute rating limits.

2) GND voltage

Make sure that the GND terminal potential is maintained at the minimum in any operating state, and is always kept lower than the potential of all other pins.

3) Thermal design

Use a thermal design that allows for sufficient margin in light of the power dissipation ( $P_d$ ) in actual operating conditions.

4) Pin shorts and mounting errors

Use caution when positioning the IC for mounting on printed circuit boards. Mounting errors, such as improper positioning or orientation, may damage or destroy the device. The IC may also be damaged or destroyed if output pins are shorted together, or if shorts occur between the output pin and supply pin or GND.

5) Positioning components in proximity to the Hall IC and magnet

Positioning magnetic components in close proximity to the Hall IC or magnet may alter the magnetic field, and therefore magnetic detection operation. Thus, placing magnetic components near the Hall IC and magnet should be avoided whenever possible. However, if such a design is not possible it is important to thoroughly test and evaluate the performance with the magnetic component(s) in place to verify normal operation before implementation.

6) Slide-by position sensing

Fig.30 depicts the slide-by configuration employed for position sensing. Note that when the gap ( $d$ ) between the magnet and the Hall IC is narrowed, the reverse magnetic field generated by the magnet can cause the IC to malfunction. As seen in Fig.31, the magnetic field runs in opposite directions at Point A and Point B. Since the bipolar detection Hall IC can detect the S-pole at Point A and the N-pole at Point B, it can wind up switching output ON as the magnet slides by in the process of position detection. Fig. 32 plots magnetic flux density during the magnet slide-by. Although a reverse magnetic field was generated in the process, the magnetic flux density decreased compared with the center of the magnet. This demonstrates that slightly widening the gap ( $d$ ) between the magnet and Hall IC reduces the reverse magnetic field and prevents malfunctions.

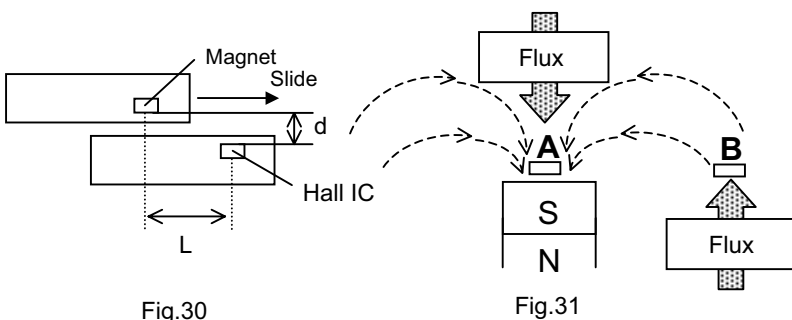

Fig.30

Fig.31

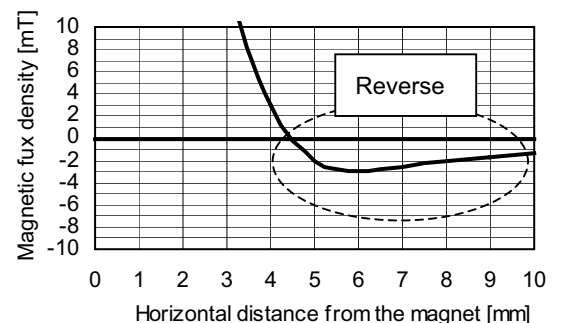

Fig.32

7) Operation in strong electromagnetic fields

Exercise extreme caution when using the device in the presence of a strong electromagnetic field, as such use may cause the IC to malfunction.

8) Common impedance

Make sure that the power supply and GND wiring limits common impedance as much as possible by, for example, employing short, thick supply and ground lines. Also, take measures to minimize ripple such as using an inductor or capacitor.

9) GND wiring pattern

When both a small-signal GND and high-current GND are provided, single-point grounding at the reference point of the set PCB is recommended, in order to separate the small-signal and high-current patterns and to ensure that voltage changes due to the wiring resistance and high current do not cause any voltage fluctuation in the small-signal GND. In the same way, care must also be taken to avoid wiring pattern fluctuations in the GND wiring pattern of external components.

10) Exposure to strong light

Exposure to halogen lamps, UV and other strong light sources may cause the IC to malfunction. If the IC is subject to such exposure, provide a shield or take other measures to protect it from the light. In testing, exposure to white LED and fluorescent light sources was shown to have no significant effect on the IC.

● Part Number Explanation (Determining the part number when ordering)

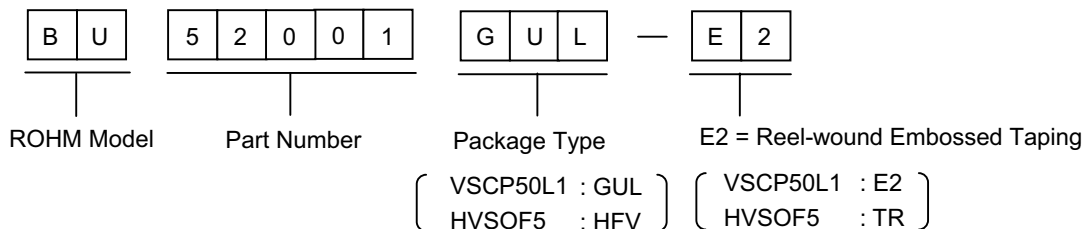

**VCSP50L1**

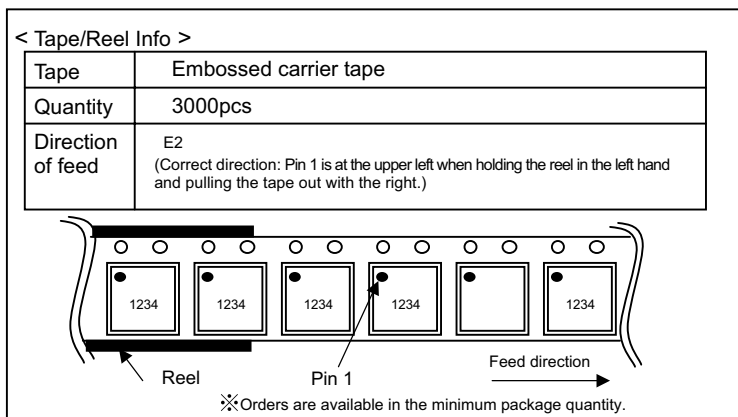
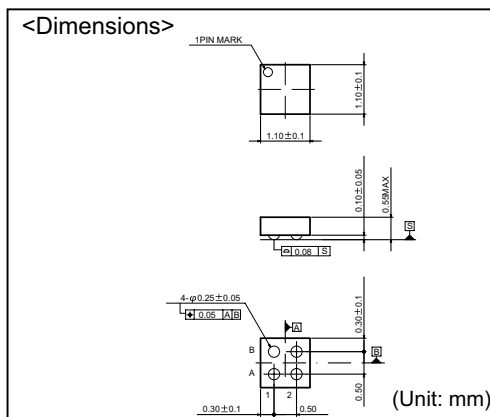

**HVSO5**

